



Full Feature Peak Reducing EMI Solution Industrial Temperature

Features

- Cypress PREMIS™ family offering
- Generates an EMI optimized clocking signal at the output
- Selectable output frequency range
- Single 1.25% or 3.75% down(W182I) or center spread(W182I-5) output
- Integrated loop filter components
- Operates with a 3.3 or 5V supply
- Low power CMOS design
- Available in 14-pin SOIC (Small Outline Integrated Circuit)

Key Specifications

Supply Voltages: .....  $V_{DD} = 3.3V \pm 5\%$   
 or  $V_{DD} = 5V \pm 10\%$

Frequency Range: .....  $6\text{ MHz} \leq F_{in} \leq 28\text{ MHz}$

Cycle to Cycle Jitter: ..... 300 ps (max.)

Selectable Spread Percentage: ..... 1.25% or 3.75%

Output Duty Cycle: ..... 40/60% (worst case)

Output Rise and Fall Time: ..... 5 ns (max.)

Table 1. Modulation Width Selection

| SS% | W182I Output                               | W182I-5 Output                               |
|-----|--|--|
| 0   | $F_{in} \geq F_{out} \geq F_{in} - 1.25\%$ | $F_{in} + 0.625\% \geq F_{in} \geq -0.625\%$ |
| 1   | $F_{in} \geq F_{out} \geq F_{in} - 3.75\%$ | $F_{in} + 1.875\% \geq F_{in} \geq -1.875\%$ |

Table 2. Frequency Range Selection

| FS2 | FS1 | Frequency Range                                |
|-----|-----|--|
| 0   | 0   | $6\text{ MHz} \leq F_{IN} \leq 8\text{ MHz}$   |
| 0   | 1   | $8\text{ MHz} \leq F_{IN} \leq 13\text{ MHz}$  |
| 1   | 0   | $13\text{ MHz} \leq F_{IN} \leq 17\text{ MHz}$ |
| 1   | 1   | $17\text{ MHz} \leq F_{IN} \leq 28\text{ MHz}$ |

Simplified Block Diagram

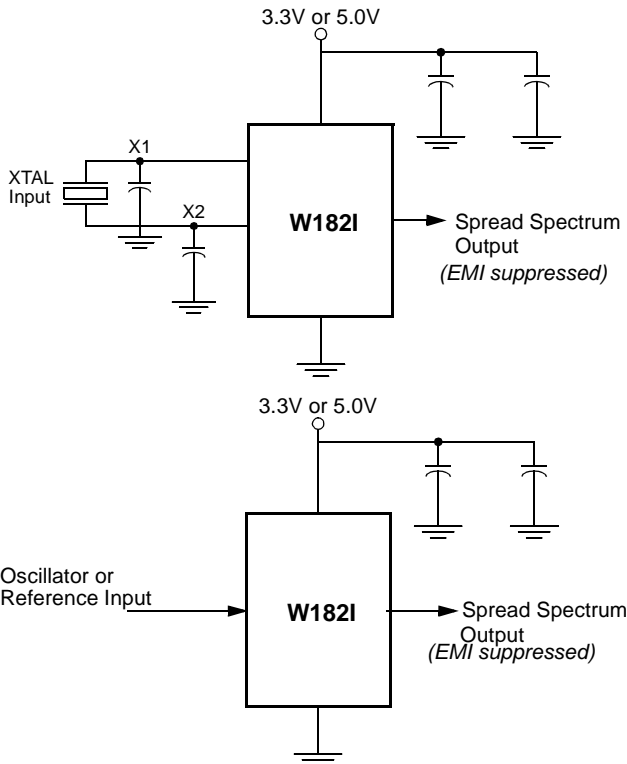

Pin Configuration

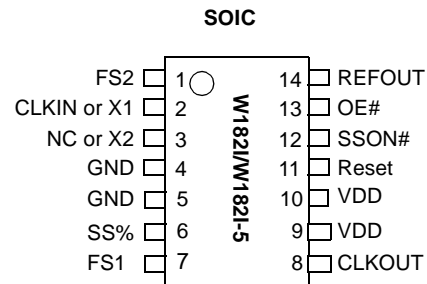

**Pin Definitions**

| Pin Name    | Pin No. | Pin Type | Pin Description  |
|-------------|---------|----------|--|
| CLKOUT      | 8       | O        | <b>Output Modulated Frequency:</b> Frequency modulated copy of the input clock (SSON# asserted).   |
| REFOUT      | 14      | O        | <b>Non-Modulated Output:</b> This pin provides a copy of the reference frequency. This output will not have the Spread Spectrum feature enabled regardless of the state of logic input SSON#.  |
| CLKIN or X1 | 2       | I        | <b>Crystal Connection or External Reference Frequency Input:</b> This pin has dual functions. It may either be connected to an external crystal, or to an external reference clock.  |
| NC or X2    | 3       | I        | <b>Crystal Connection:</b> Input connection for an external crystal. If using an external reference, this pin must be left unconnected.  |
| SSON#       | 12      | I        | <b>Spread Spectrum Control (Active LOW):</b> Asserting this signal (active LOW) turns the internal modulation waveform on. This pin has an internal pull-down resistor.  |
| SS%         | 6       | I        | <b>Modulation Width Selection:</b> When Spread Spectrum feature is turned on, this pin is used to select the amount of variation and peak EMI reduction that is desired on the output signal. This pin has an internal pull-up resistor. |
| OE#         | 13      | I        | <b>Output Enable (Active LOW):</b> When this pin is held HIGH, the output buffers are placed in a high-impedance mode. This pin has an internal pull-down resistor.  |
| Reset       | 11      | I        | <b>Modulation Profile Restart:</b> A rising edge on this input restarts the modulation pattern at the beginning of its defined path. This pin has an internal pull-down resistor.  |
| FS1:2       | 7, 1    | I        | <b>Frequency Selection Bit(s):</b> These pins select the frequency range of operation. Refer to <i>Table 2</i> . These pins have internal pull-up resistors.   |
| VDD         | 9,10    | P        | <b>Power Connection:</b> Connected to 3.3V or 5V power supply.   |
| GND         | 4,5     | G        | <b>Ground Connection:</b> Connect all ground pins to the common ground plane.  |

## Overview

The W182I product is one of a series of devices in the Cypress PREMIS family. The PREMIS family incorporates the latest advances in PLL spread spectrum frequency synthesizer techniques. By frequency modulating the output with a low-frequency carrier, peak EMI is greatly reduced. Use of this technology allows systems to pass increasingly difficult EMI testing without resorting to costly shielding or redesign.

In a system, not only is EMI reduced in the various clock lines, but also in all signals which are synchronized to the clock. Therefore, the benefits of using this technology increase with the number of address and data lines in the system. The Simplified Block Diagram shows a simple implementation.

## Functional Description

The W182I uses a Phase-Locked Loop (PLL) to frequency modulate an input clock. The result is an output clock whose frequency is slowly swept over a narrow band near the input signal. The basic circuit topology is shown in *Figure 1*. The input reference signal is divided by Q and fed to the phase detector. A signal from the VCO is divided by P and fed back to the phase detector also. The PLL will force the frequency of the VCO output signal to change until the divided output signal and the divided reference signal match at the phase detector input. The output frequency is then equal to the ratio of P/Q

times the reference frequency. (Note: For the W182I the output frequency is nominally equal to the input frequency.) The unique feature of the Spread Spectrum Frequency Timing Generator is that a modulating waveform is superimposed at the input to the VCO. This causes the VCO output to be slowly swept across a predetermined frequency band.

Because the modulating frequency is typically 1000 times slower than the fundamental clock, the spread spectrum process has little impact on system performance.

### Frequency Selection With SSFTG

In Spread Spectrum Frequency Timing Generation, EMI reduction depends on the shape, modulation percentage, and frequency of the modulating waveform. While the shape and frequency of the modulating waveform are fixed for a given frequency, the modulation percentage may be varied.

Using frequency select bits (FS2:1 pins), the frequency range can be set (see *Table 2*). Spreading percentage is set with pin SS% as shown in *Table 1*.

A larger spreading percentage improves EMI reduction. However, large spread percentages may either exceed system maximum frequency ratings or lower the average frequency to a point where performance is affected. For these reasons, spreading percentage options are provided.

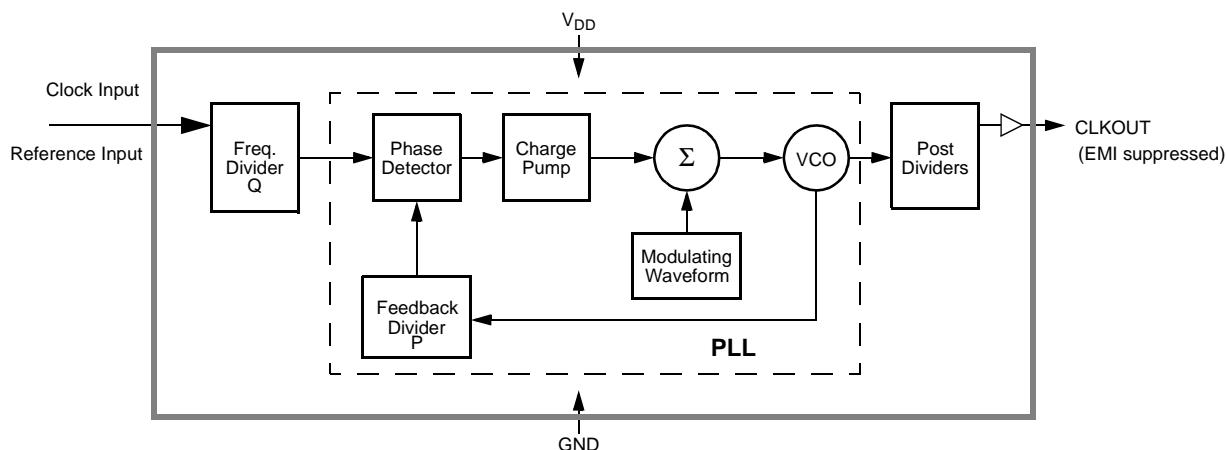

**Figure 1. Functional Block Diagram**

### Spread Spectrum Frequency Timing Generation

The device generates a clock that is frequency modulated in order to increase the bandwidth that it occupies. By increasing the bandwidth of the fundamental and its harmonics, the amplitudes of the radiated electromagnetic emissions are reduced. This effect is depicted in *Figure 2*.

As shown in *Figure 2*, a harmonic of a modulated clock has a much lower amplitude than that of an unmodulated signal. The reduction in amplitude is dependent on the harmonic number and the frequency deviation or spread. The equation for the reduction is:

$$dB = 6.5 + 9 * \log_{10}(P) + 9 * \log_{10}(F)$$

Where *P* is the percentage of deviation and *F* is the frequency in MHz where the reduction is measured.

The output clock is modulated with a waveform depicted in *Figure 3*. This waveform, as discussed in "Spread Spectrum Clock Generation for the Reduction of Radiated Emissions" by Bush, Fessler, and Hardin produces the maximum reduction in the amplitude of radiated electromagnetic emissions. *Figure 3* details the Cypress spreading pattern. Cypress does offer options with more spread and greater EMI reduction. Contact your local Sales representative for details on these devices.

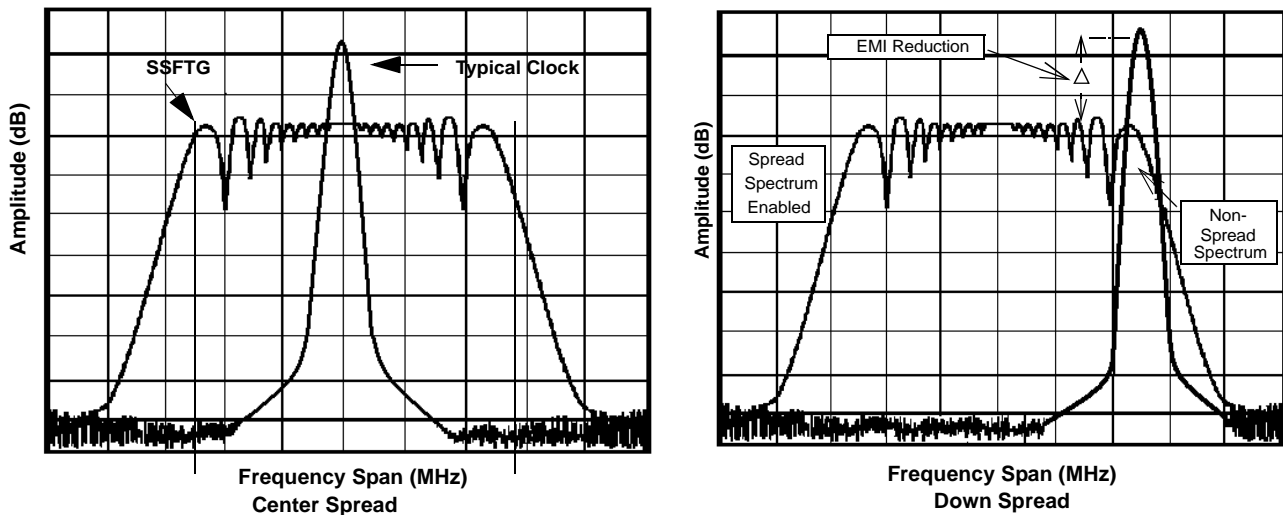

**Figure 2. Clock Harmonic with and without SSCG Modulation Frequency Domain Representation**

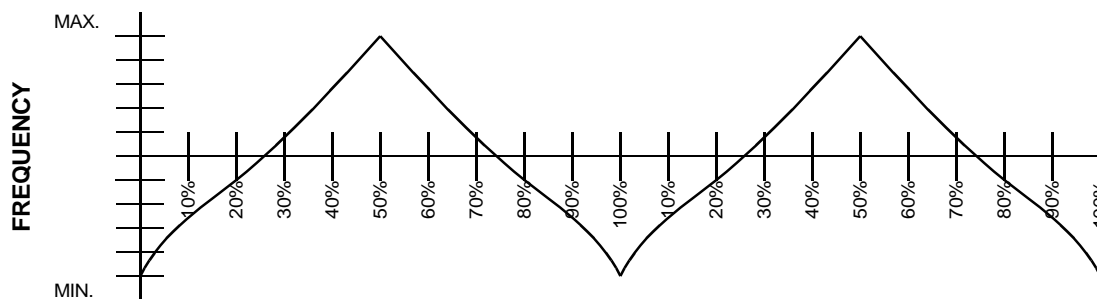

**Figure 3. Typical Modulation Profile**

**Absolute Maximum Ratings<sup>[1]</sup>**

Stresses greater than those listed in this table may cause permanent damage to the device. These represent a stress rating only. Operation of the device at these or any other conditions

above those specified in the operating sections of this specification is not implied. Maximum conditions for extended periods may affect reliability.

| Parameter        | Description                            | Rating       | Unit |
|------------------|--|--------------|------|
| $V_{DD}, V_{IN}$ | Voltage on any pin with respect to GND | -0.5 to +7.0 | V    |
| $T_{STG}$        | Storage Temperature                    | -65 to +150  | °C   |
| $T_A$            | Operating Temperature                  | -40 to +85   | °C   |
| $T_B$            | Ambient Temperature under Bias         | -55 to +125  | °C   |
| $P_D$            | Power Dissipation                      | 0.5          | W    |

**DC Electrical Characteristics:  $-40^{\circ}\text{C} < T_A < 85^{\circ}\text{C}$ ,  $V_{DD} = 3.3\text{V} \pm 5\%$** 

| Parameter | Description            | Test Condition                            | Min. | Typ. | Max. | Unit |
|-----------|------------------------|---|------|------|------|------|
| $I_{DD}$  | Supply Current         |   |      | 18   | 32   | mA   |
| $t_{ON}$  | Power Up Time          | First locked clock cycle after Power Good |      |      | 5    | ms   |
| $V_{IL}$  | Input Low Voltage      |   |      |      | 0.8  | V    |
| $V_{IH}$  | Input High Voltage     |   | 2.4  |      |      | V    |
| $V_{OL}$  | Output Low Voltage     |   |      |      | 0.4  | V    |
| $V_{OH}$  | Output High Voltage    |   | 2.4  |      |      | V    |
| $I_{IL}$  | Input Low Current      | Note 2                                    | -50  |      |      | μA   |
| $I_{IH}$  | Input High Current     | Note 2                                    |      |      | 50   | μA   |
| $I_{OL}$  | Output Low Current     | @ 0.4V, $V_{DD} = 3.3\text{V}$            |      | 15   |      | mA   |
| $I_{OH}$  | Output High Current    | @ 2.4V, $V_{DD} = 3.3\text{V}$            |      | 15   |      | mA   |
| $C_I$     | Input Capacitance      |   |      |      | 7    | pF   |
| $R_P$     | Input Pull-Up Resistor |   |      | 500  |      | kΩ   |
| $Z_{OUT}$ | Clock Output Impedance |   |      | 25   |      | Ω    |

**Note:**

1. Single Power Supply: The voltage on any input or I/O pin cannot exceed the power pin during power-up.
2. Inputs FS2:1 have a pull-up resistor; Input SSON# has a pull-down resistor.

**DC Electrical Characteristics:**  $-40^{\circ}\text{C} < T_A < 85^{\circ}\text{C}$ ,  $V_{DD} = 5\text{V} \pm 10\%$ 

| Parameter | Description            | Test Condition                            | Min.        | Typ. | Max.         | Unit          |
|-----------|------------------------|---|-------------|------|--------------|---------------|
| $I_{DD}$  | Supply Current         |   |             | 30   | 50           | mA            |
| $t_{ON}$  | Power Up Time          | First locked clock cycle after Power Good |             |      | 5            | ms            |
| $V_{IL}$  | Input Low Voltage      |   |             |      | $0.15V_{DD}$ | V             |
| $V_{IH}$  | Input High Voltage     |   | $0.7V_{DD}$ |      |              | V             |
| $V_{OL}$  | Output Low Voltage     |   |             |      | 0.4          | V             |
| $V_{OH}$  | Output High Voltage    |   | 2.4         |      |              | V             |
| $I_{IL}$  | Input Low Current      | Note 3                                    | -50         |      |              | $\mu\text{A}$ |
| $I_{IH}$  | Input High Current     | Note 3                                    |             |      | 50           | $\mu\text{A}$ |
| $I_{OL}$  | Output Low Current     | @ 0.4V, $V_{DD} = 5\text{V}$              |             | 24   |              | mA            |
| $I_{OH}$  | Output High Current    | @ 2.4V, $V_{DD} = 5\text{V}$              |             | 24   |              | mA            |
| $C_I$     | Input Capacitance      |   |             |      | 7            | pF            |
| $R_P$     | Input Pull-Up Resistor |   |             | 500  |              | k $\Omega$    |
| $Z_{OUT}$ | Clock Output Impedance |   |             | 25   |              | $\Omega$      |

**AC Electrical Characteristics:**  $T_A = -40^{\circ}\text{C}$  to  $+85^{\circ}\text{C}$ ,  $V_{DD} = 3.3\text{V} \pm 5\%$  or  $5\text{V} \pm 10\%$ 

| Symbol    | Parameter              | Test Condition   | Min. | Typ. | Max. | Unit |
|-----------|------------------------|--|------|------|------|------|
| $f_{IN}$  | Input Frequency        | Input Clock  | 8    |      | 28   | MHz  |
| $f_{OUT}$ | Output Frequency       | Spread Off   | 8    |      | 28   | MHz  |
| $t_R$     | Output Rise Time       | 15-pF load, 0.8V–2.4V  |      | 2    | 5    | ns   |
| $t_F$     | Output Fall Time       | 15-pF load, 2.4–0.8V   |      | 2    | 5    | ns   |
| $t_{OD}$  | Output Duty Cycle      | 15-pF load   | 40   |      | 60   | %    |
| $t_{ID}$  | Input Duty Cycle       |  | 40   |      | 60   | %    |
| $t_{JC}$  | Jitter, Cycle-to-Cycle | $13\text{ MHz} \leq F_{IN} \leq 17\text{ MHz}$                                   |      | 250  | 400  | ps   |
| $t_{JC}$  | Jitter, Cycle-to-Cycle | $F_{IN} < 13\text{ MHz}$ or $F_{IN} > 17\text{ MHz}$                             |      |      | 200  | ps   |
|           | Harmonic Reduction     | $f_{out} = 20\text{ MHz}$ , third harmonic measured, reference board, 15-pF load | 8    |      |      | dB   |

**Note:**

- Inputs FS1:2 have a pull-up resistor; Input SSON# has a pull-down resistor.

## Application Information

### Recommended Circuit Configuration

For optimum performance in system applications the power supply decoupling scheme shown in *Figure 4* should be used.

$V_{DD}$  decoupling is important to both reduce phase jitter and EMI radiation. The 0.1- $\mu\text{F}$  decoupling capacitor should be placed as close to the  $V_{DD}$  pin as possible, otherwise the in-

creased trace inductance will negate its decoupling capability. The 10- $\mu\text{F}$  decoupling capacitor shown should be a tantalum type. For further EMI protection, the  $V_{DD}$  connection can be made via a ferrite bead, as shown.

### Recommended Board Layout

*Figure 5* shows a recommended a 2-layer board layout.

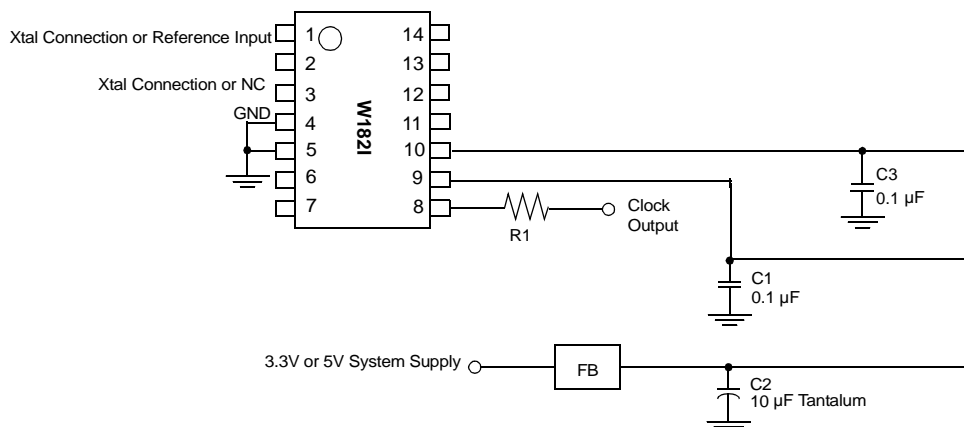

**Figure 4. Recommended Circuit Configuration**

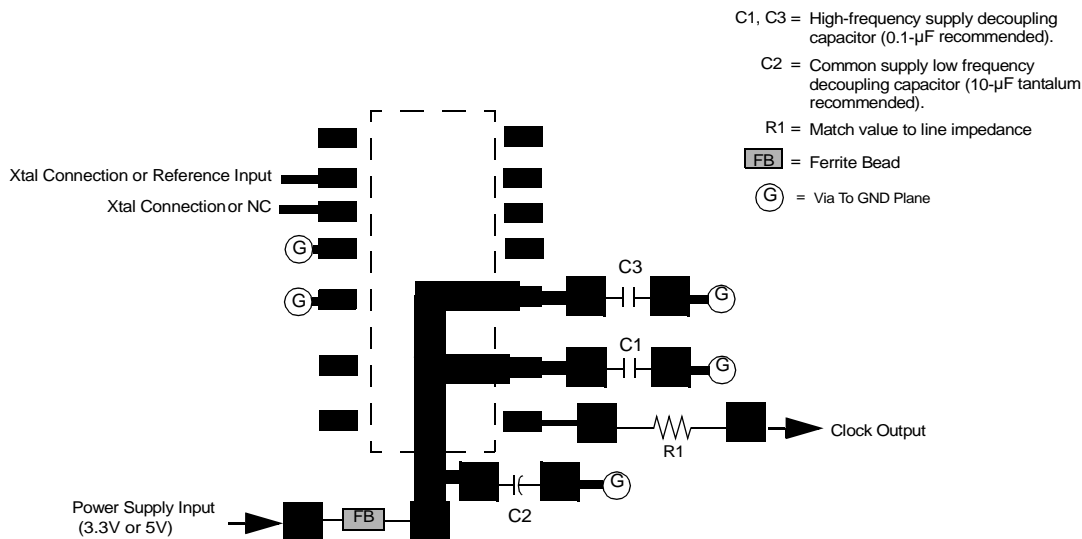

**Figure 5. Recommended Board Layout (2-Layer Board)**

**Ordering Information**

| Ordering Code | Package Type                                  | Product Flow             |
|---------------|---|--------------------------|
| W182GI        | 14-Pin Plastic SOIC (150-mil)                 | Industrial, -40° to 85°C |
| W182GIT       | 14-Pin Plastic SOIC (150-mil) - Tape and Reel | Industrial, -40° to 85°C |
| W182-5GI      | 14-Pin Plastic SOIC (150-mil)                 | Industrial, -40° to 85°C |
| W182-5GIT     | 14-Pin Plastic SOIC (150-mil) -Tape and Reel  | Industrial, -40° to 85°C |

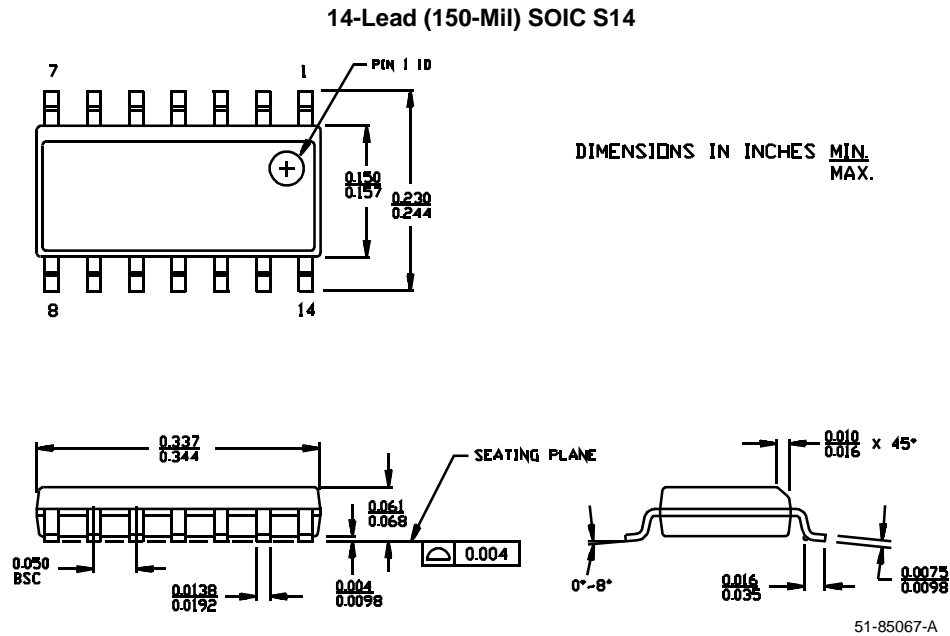
**Package Drawing and Dimension**

PREMIS is a trademark of Cypress Semiconductor Corporation. All product and company names may be trademarks of their respective holders.



| <b>Document Title: W182i Full Feature Peak Reducing EMI Solution Industrial Temperature</b> |                |                   |                        |  |
|---|----------------|-------------------|------------------------|--|
| <b>Document Number: 38-07269</b>  |                |                   |                        |  |
| <b>REV.</b>   | <b>ECN NO.</b> | <b>Issue Date</b> | <b>Orig. of Change</b> | <b>Description of Change</b>   |
| **  | 110534         | 12/02/01          | SZV                    | Change from Spec number: 38-01139 to 38-07269  |
| *A  | 117405         | 08/16/02          | RGL                    | Corrected the Ordering Information to match the DevMaster<br>Corrected the Operating Temp. range in page 5.<br>Corrected the temperature range in DC Electrical Char. table in page 6. |
| *B  | 122696         | 12/28/02          | RBI                    | Added power up requirements to maximum rating information.   |