

MOS INTEGRATED CIRCUIT

μ PD784915B, 784916B

16-BIT SINGLE-CHIP MICROCONTROLLERS

DESCRIPTION

The μ PD784915B, 784916B are members of the NEC 78K/IV Series of microcontrollers equipped with a high-speed 16-bit CPU and are versions with improved electrical characteristics of the μ PD784915A, 784916A of the μ PD784915 Subseries.

This series contains many peripheral hardware units ideal for VCR control, such as a multi-function timer unit (super timer unit) suitable for software servo control and VCR analog circuits.

A one-time PROM version of the μ PD784916B, the μ PD78P4916, is also available.

Detailed function descriptions are provided in the following user's manuals. Be sure to read them before designing.

μ PD784915 Subseries User's Manual - Hardware: U10444E
78K/IV Series User's Manual - Instruction: U10905E

FEATURES

- High instruction execution speed realized by 16-bit CPU core
 - Minimum instruction execution time: 250 ns (with 8-MHz internal clock)
- High internal memory capacity

Part Number	ROM	RAM
μ PD784915B	49152 bytes	1280 bytes
μ PD784916B	63488 bytes	

- VCR analog circuits conforming to VHS Standard
 - CTL amplifier
 - RECCTL driver (rewritable)
 - CFG amplifier
 - DFG amplifier
 - DPG comparator
 - DDFG separation circuit (ternary separation circuit)
 - Reel FG comparator (2 channels)
 - CSYNC comparator
- Timer unit (super timer unit) for servo control
- Serial interface: 2 channels (3-wire serial I/O)
- A/D converter: 12 channels (conversion time: 10 μ s)
- Low-frequency oscillation mode: main system clock frequency = internal clock frequency
- Low-power dissipation mode: CPU can operate with a subsystem clock.
- Supply voltage range: $V_{DD} = 2.7$ to 5.5 V
- Hardware watch function: watch operation at low voltage ($V_{DD} = 2.7$ V (MIN.)) and low current

APPLICATIONS

Control system/servo/timer of VCR

Unless mentioned otherwise, the μ PD784916B is described as the representative product.

The information in this document is subject to change without notice

ORDERING INFORMATION

Part Number	Package
μPD784915BGF-xxx-3BA	100-pin plastic QFP (14 x 20 mm)
μPD784916BGF-xxx-3BA	100-pin plastic QFP (14 x 20 mm)

Remark xxx indicates ROM code suffix.

Product Development of 78K/IV Series

: Under mass production

: Under development

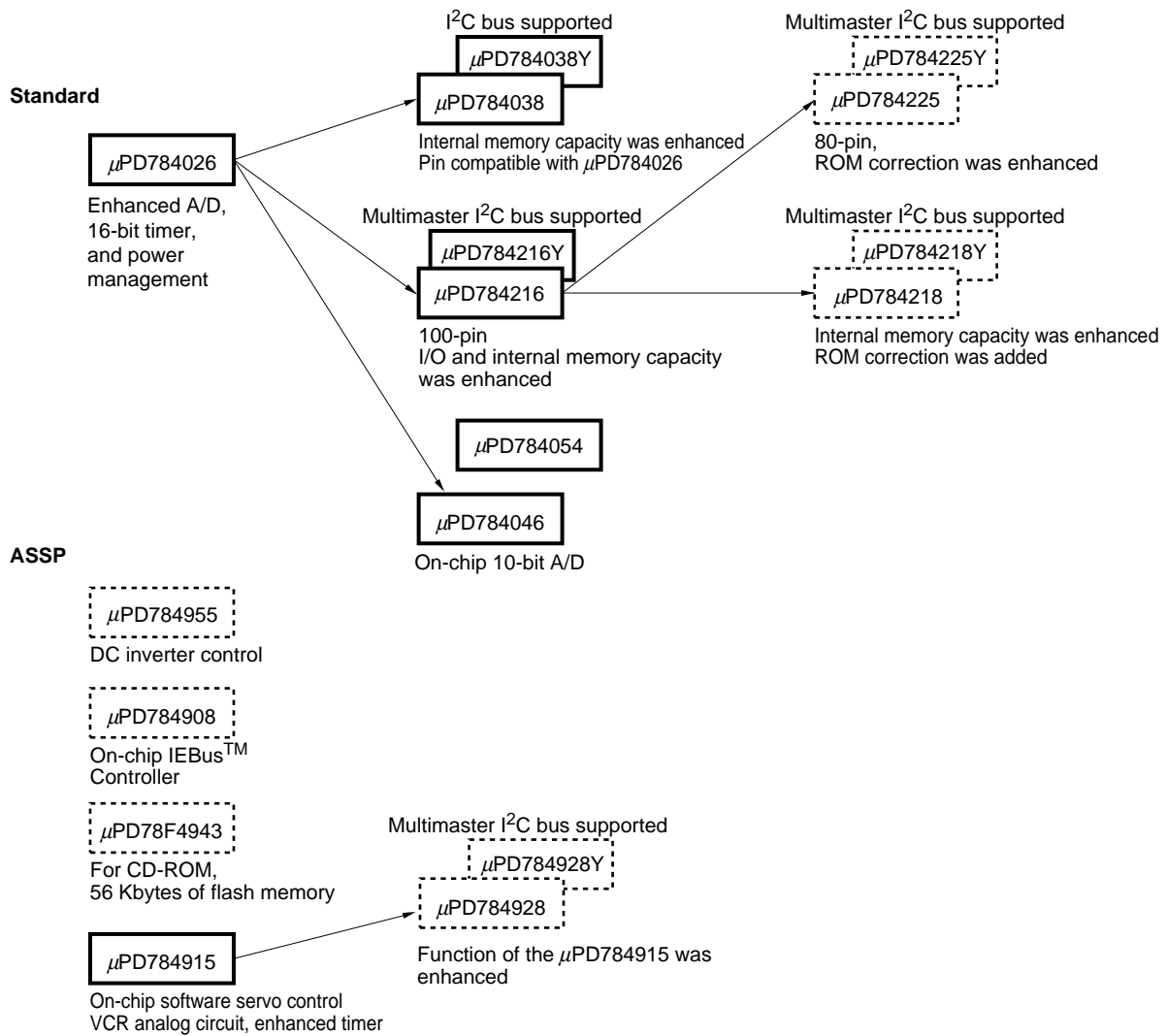

Function List (1/2)

Item		μPD784915B	μPD784916B			
Internal ROM capacity		49152 bytes	63488 bytes			
Internal RAM capacity		1280 bytes				
Operating clock		16 MHz (internal clock: 8 MHz) Low frequency oscillation mode: 8 MHz (internal clock: 8 MHz) Low power dissipation mode: 32.768 kHz (subsystem clock)				
Minimum instruction execution time		250 ns (with 8-MHz internal system clock)				
I/O ports		54 { input : 8 I/O : 46				
Real-time output port		11 (including one each for pseudo V _{SYNC} , head amplifier switch, and chrominance rotation)				
Super timer unit	Timer/counter	Timer/counter	Compare register	Capture register	Remark	
		TM0 (16 bits)	3	-		
		TM1 (16 bits)	3	1		
		FRC (22 bits)	-	6		
		TM3 (16 bits)	2	1		
		UDC (5 bits)	1	-		
		EC (8 bits)	4	-	For HSW signal generation	
	EDV (8 bits)	1	-	For CFG signal division		
	Capture register	Input signal	Number of bits	Measurable cycle	Operating edge	
		CFG	22	125 ns to 524 ms	↑	↓
DFG		22	125 ns to 524 ms	↑		
HSW		16	1 μs to 65.5 ms	↑	↓	
V _{SYNC}		22	125 ns to 524 ms	↑		
CTL		16	1 μs to 65.5 ms	↑	↓	
T _{REEL}		22	125 ns to 524 ms	↑	↓	
S _{REEL}	22	125 ns to 524 ms	↑	↓		
VCR special circuit	<ul style="list-style-type: none"> • V_{SYNC} separation circuit, H_{SYNC} separation circuit • VISS detection, wide aspect detection circuits • Field identification circuit • Head amplifier switch/chroma rotation output circuit 					
General-purpose timer	Timer	Compare register	Capture register			
	TM2 (16 bits)	1	—			
	TM4 (16 bits)	1 (capture/compare)	1			
	TM5 (16 bits)	1	—			
PWM output	<ul style="list-style-type: none"> • 16-bit accuracy : 3 channels (carrier frequency: 62.5 kHz) • 8-bit accuracy : 3 channels (carrier frequency: 62.5 kHz) 					
Serial interface	3-wire serial I/O: 2 channels <ul style="list-style-type: none"> • BUSY/STRB control (1 channel only) 					
A/D converter	8-bit resolution × 12 channels, conversion time: 10 μs					

Function List (2/2)

Item	μPD784915B	μPD784916B
Analog circuit	<ul style="list-style-type: none"> • CTL amplifier • RECCTL driver (rewritable) • DFG amplifier, DPG comparator, CFG amplifier • DPMG separation circuit (ternary separation circuit) • Reel FG comparator (2 channels) • CSYNC comparator 	
Interrupt	4 levels (programmable), vector interrupt, macro service, context switching	
External	9 (including NMI)	
Internal	19 (including software interrupt)	
Standby function	HALT/STOP mode/low power dissipation mode/low power dissipation HALT mode STOP mode can be released by input of valid edge of NMI pin, watch interrupt (INTW), or INTP1/INTP2/KEY0-KEY4 pins	
Watch function	0.5-second measurement, low-voltage operation ($V_{DD} = 2.7\text{ V}$)	
Supply voltage	$V_{DD} = 2.7\text{ to }5.5\text{ V}$	
Package	100-pin plastic QFP (14 × 20 mm)	

PIN CONFIGURATION (Top View)

- 100-pin plastic QFP (14 x 20 mm)

μPD784915BGF-xxx-3BA

μPD784916BGF-xxx-3BA

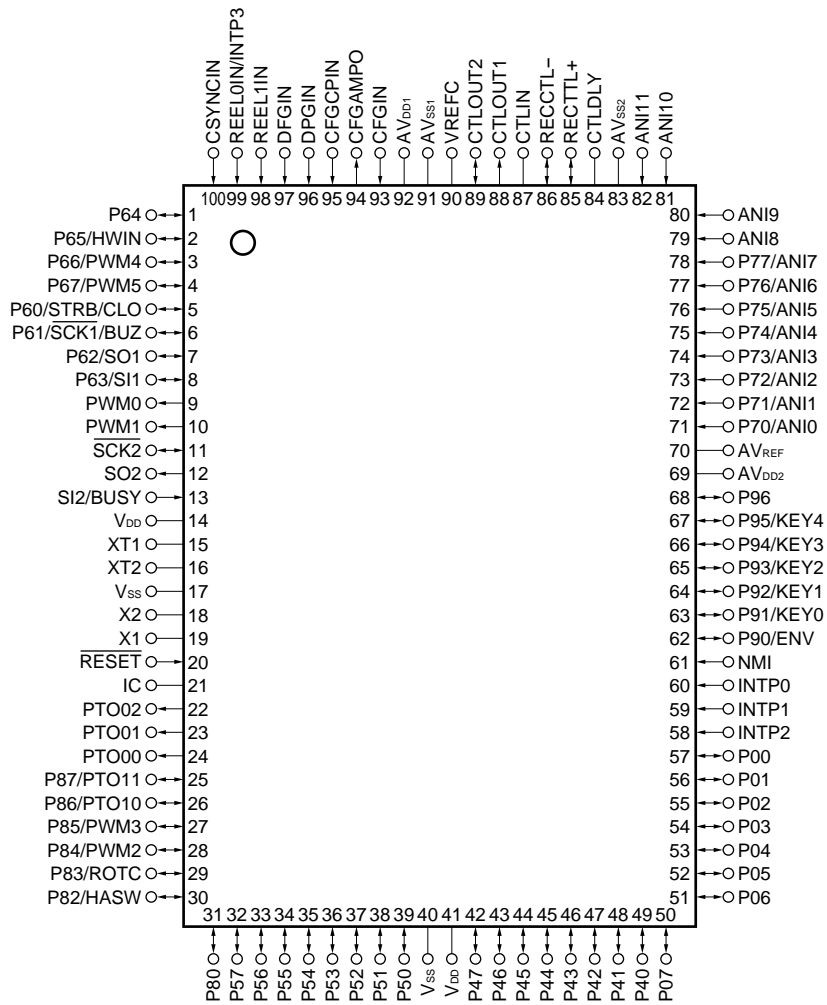

Caution Directly connect the IC (Internally Connected) pin to Vss.

ANI0-ANI11	: Analog Input	P00-P07	: Port0
AV _{DD1} , AV _{DD2}	: Analog Power Supply	P40-P47	: Port4
AV _{SS1} , AV _{SS2}	: Analog Ground	P50-P57	: Port5
AV _{REF}	: Analog Reference Voltage	P60-P67	: Port6
BUSY	: Serial Busy	P70-P77	: Port7
BUZ	: Buzzer Output	P80, P82-P87	: Port8
CFGAMPO	: Capstan FG Amplifier Output	P90-P96	: Port9
CFGCPIN	: Capstan FG Capacitor Input	PTO00-PTO02	: Programmable Timer Output
CFGIN	: Analog Unit Input	PTO10, PTO11	
CLO	: Clock Output	PWM0-PWM5	: Pulse Width Modulation Output
CSYNCIN	: Analog Unit Input	RECCTL+, RECCTL-	: RECCTL Output/PBCLT Input
CTLDLY	: Control Delay Input	REEL0IN, REEL1IN	: Analog Unit Input
CTLIN	: CTL Amplifier Input Capacitor	RESET	: Reset
CTLOUT1, CTLOUT2	: CTL Amplifier Output	ROTC	: Chrominance Rotate Output
DFGIN	: Analog Unit Input	SCK1, SCK2	: Serial Clock
DPGIN	: Analog Unit Input	SI1, SI2	: Serial Input
ENV	: Envelope Input	SO1, SO2	: Serial Output
HASW	: Head Amplifier Switch Output	STRB	: Serial Strobe
HWIN	: Hardware Timer External Input	V _{DD}	: Power Supply
IC	: Internally Connected	VREFC	: Reference Amplifier Capacitor
INTP0-INTP3	: Interrupt From Peripherals	V _{SS}	: Ground
KEY0-KEY4	: Key Return	X1, X2	: Crystal (Main System Clock)
NMI	: Nonmaskable Interrupt	XT1, XT2	: Crystal (Subsystem Clock)

INTERNAL BLOCK DIAGRAM

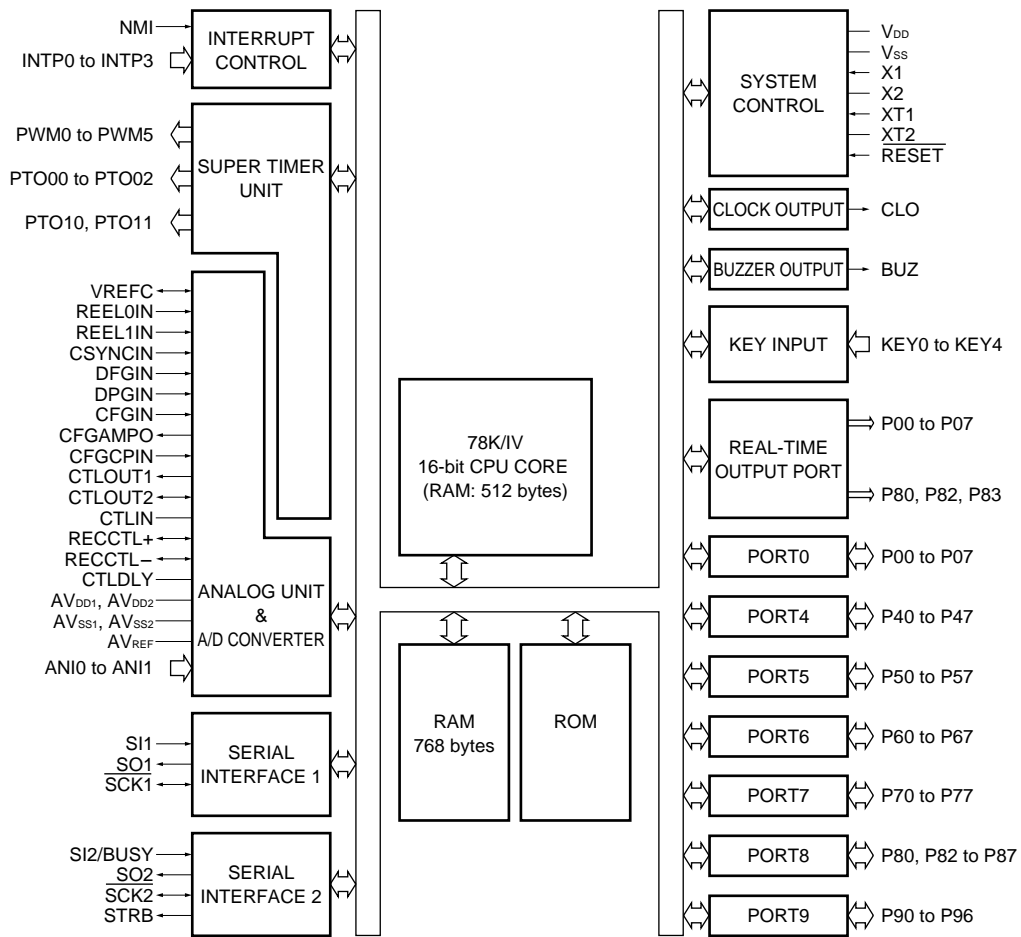

Remark Internal ROM capacity depends on the product.

SYSTEM CONFIGURATION EXAMPLE

- Camera-contained VCR

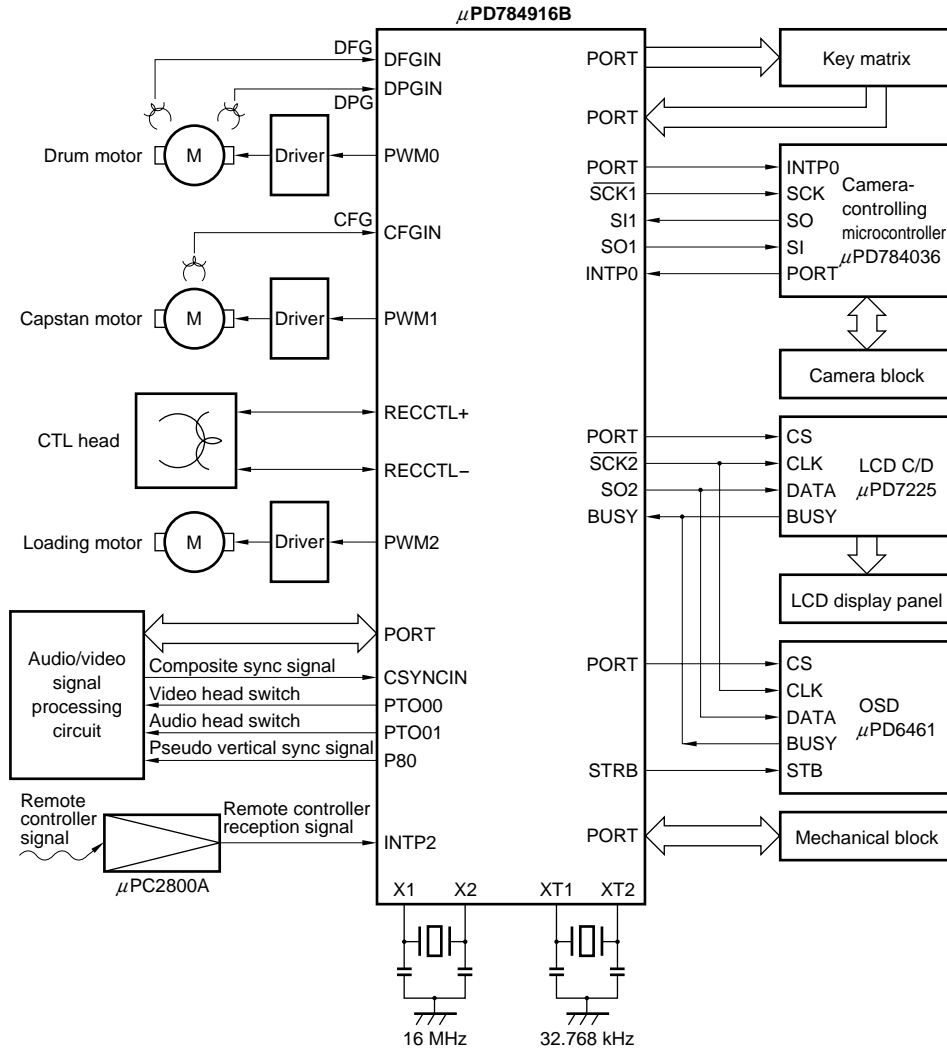

• Stationary VCR

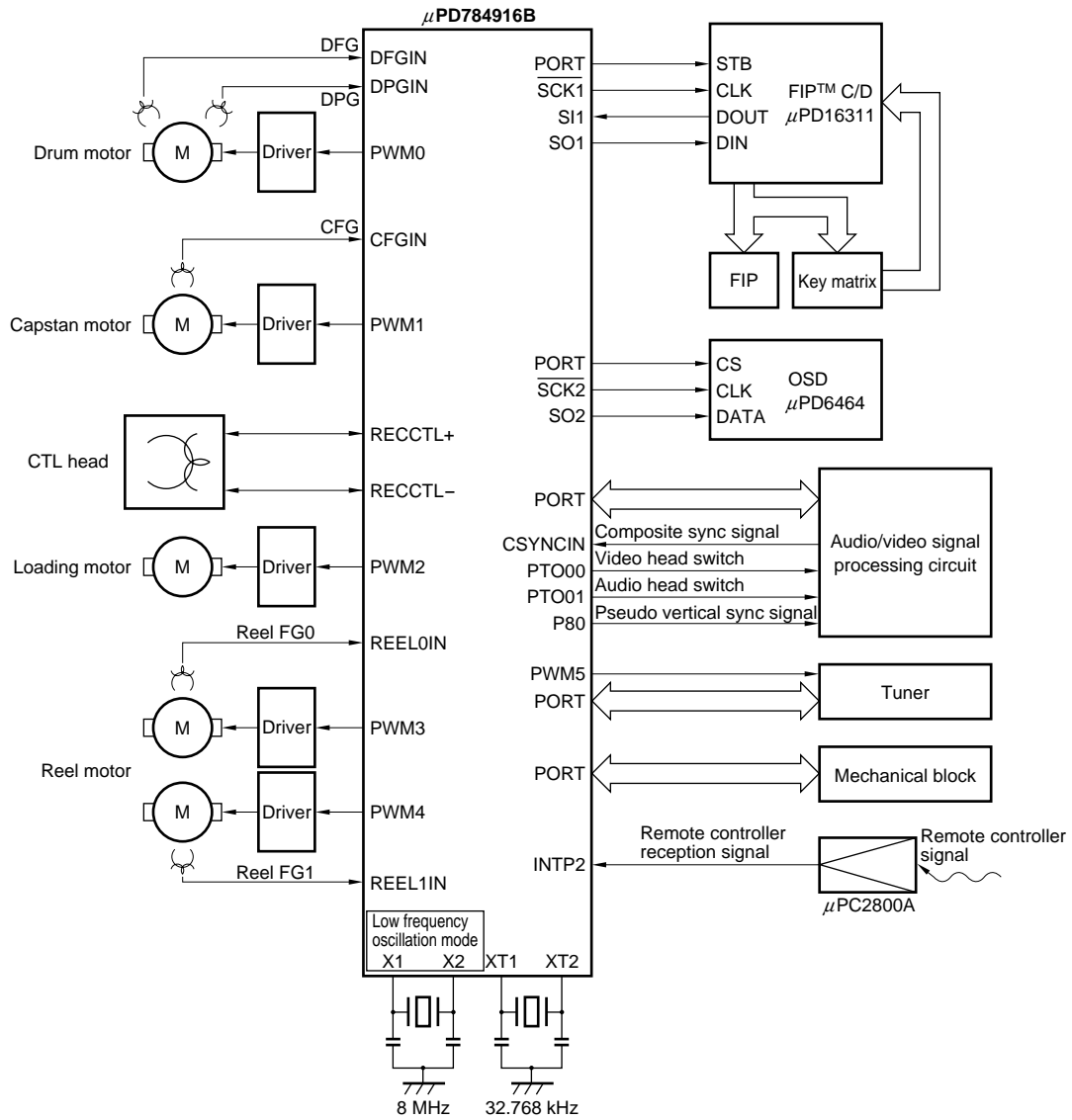

CONTENTS

1. DIFFERENCES AMONG μPD784915 SUBSERIES PRODUCTS	11
2. PIN FUNCTIONS	12
2.1 Port Pins	12
2.2 Non-Port Pins	13
2.3 I/O Circuits and Connection of Unused Pins	15
3. INTERNAL BLOCK FUNCTIONS	19
3.1 CPU Registers	19
3.1.1 General-purpose registers	19
3.1.2 Other CPU registers	20
3.2 Memory Space	20
3.3 Special Function Registers (SFRs)	23
3.4 Ports	28
3.5 Real-time Output Port	29
3.6 Super Timer Unit	33
3.7 Serial Interface	38
3.8 A/D Converter	40
3.9 VCR Analog Circuits	41
3.10 Watch Function	47
3.11 Clock Output Function	48
4. INTERNAL/EXTERNAL CONTROL FUNCTION	49
4.1 Interrupt Function	49
4.1.1 Vector interrupt	51
4.1.2 Context switching	51
4.1.3 Macro service	52
4.1.4 Application example of macro service	54
4.2 Standby Function	57
4.3 Clock Generator Circuit	59
4.4 Reset Function	60
5. INSTRUCTION SETS	61
6. ELECTRICAL CHARACTERISTICS	65
7. PACKAGE DRAWING	77
8. RECOMMENDED SOLDERING CONDITIONS	78
APPENDIX A. DEVELOPMENT TOOLS	79
APPENDIX B. RELATED DOCUMENTS	81

1. DIFFERENCES AMONG μPD784915 SUBSERIES PRODUCTS

The μPD784915 Subseries consists of the six products listed in Table 1-1. The μPD784915A is a low-cost process-shrunk version of the μPD784915. The μPD784916A expands the internal ROM capacity of the μPD784915 to 62 Kbytes. The μPD784915B and 784916B feature improved electrical characteristics compared to the μPD784915A and 784916A.

The μPD78P4916 features writable one-time PROM instead of the mask ROM of the μPD784915, 784915A, 784916A, 784915B, and 784916B. Except for this substitution of PROM for ROM and the fact that PROM capacity differs from the ROM capacities offered in the other products, the μPD78P4916 has the same functions as those products.

In switching from the PROM product, used for debugging and testing application systems, to the mask ROM products for mass production, be careful to check the differences among these products.

For details on the CPU functions and the internal hardware, refer to **μPD784915 Subseries User's Manual — Hardware (U10444E)**.

Table 1-1. Differences among μPD784915 Subseries Products

Item	μPD784915, 784915A	μPD784916A	μPD784915B	μPD784916B	μPD78P4916
Internal ROM	Mask ROM				
	49152 bytes	63488 bytes	49152 bytes	63488 bytes	63232 bytes ^{Note}
Internal RAM	1280 bytes				2048 bytes ^{Note}
Internal memory capacity selection register (IMS)	Not provided				Provided
Electrical characteristics	The electrical characteristics of the μPD784915A/784916A, the μPD784915B/784916B, and the μPD78P4916 differ with respect to the items listed below. <ul style="list-style-type: none"> • P40 to P47, P50 to P57: Low-level input voltage • V_{DD} supply current • Data hold current • CTL amplifier: Phase signal elimination ratio • CFG amplifier: CFGAMPO low-level output current For details, refer to the data sheet of each product. <ul style="list-style-type: none"> • μPD784915A/784916A Data Sheet (U11022J) • μPD784915B/784916B Data Sheet (This document) • μPD78P4916 Data Sheet (U11045J) 				
Pin connections	In the μPD78P4916, pin function for PROM read/write has been added.				

Note The internal PROM and internal RAM capacities can be changed using the internal memory selection register (IMS).

Caution The PROM version and mask ROM version differ in noise immunity and noise radiation, etc. When considering replacing a PROM version with a mask ROM version when switching from preproduction to volume production, perform sufficient evaluation using a CS version (not ES version) of the mask ROM version.

2. PIN FUNCTIONS

2.1 Port Pins

Pin Name	I/O	Alternate Function	Function	
P00 to P07	I/O	Real-time output port	8-bit I/O port (port 0). <ul style="list-style-type: none"> • Can be set in input or output mode in 1-bit units. • Can be connected with software pull-up resistors. 	
P40 to P47	I/O	–	8-bit I/O port (port 4). <ul style="list-style-type: none"> • Can be set in input or output mode in 1-bit units. • Can be connected with software pull-up resistors. 	
P50 to P57	I/O	–	8-bit I/O port (port 5). <ul style="list-style-type: none"> • Can be set in input or output mode in 1-bit units. • Can be connected with software pull-up resistors. 	
P60	I/O	STRB/CLO	8-bit I/O port (port 6). <ul style="list-style-type: none"> • Can be set in input or output mode in 1-bit units. • Can be connected with software pull-up resistors. 	
P61		SCK1/BUZ		
P62		SO1		
P63		SI1		
P64		–		
P65		HWIN		
P66		PWM4		
P67		PWM5		
P70 to P77	Input	ANI0 to ANI7	8-bit input port (port 7)	
P80	I/O	Real-time output port	Pseudo Vsync output	7-bit I/O port (port 8). <ul style="list-style-type: none"> • Can be set in input or output mode in 1-bit units. • Can be connected with software pull-up resistors.
P82			HASW output	
P83			ROTC output	
P84		PWM2		
P85		PWM3		
P86		PTO10		
P87		PTO11		
P90		I/O	ENV	
P91 to P95	KEY0 to KEY4		<ul style="list-style-type: none"> • Can be set in input or output mode in 1-bit units. 	
P96	–		<ul style="list-style-type: none"> • Can be connected with software pull-up resistors. 	

2.2 Non-Port Pins (1/2)

Pin Name	I/O	Alternate Function	Function
REEL0IN	Input	INTP3	Reel FG input
REEL1IN		-	
DFGIN		-	Drum FG, PFG input (ternary)
DPGIN		-	Drum PG input
CFGIN		-	Capstan FG input
CSYNCIN		-	Composite SYNC input
CFGCPIN		-	CFG comparator input
CFGAMPO		Output	-
PTO00	Output	-	Programmable timer output of super timer unit
PTO01		-	
PTO02		-	
PTO10		P86	
PTO11		P87	
PWM0		Output	
PWM1	-		
PWM2	P84		
PWM3	P85		
PWM4	P66		
PWM5	P67		
HASW	Output	P82	Head amplifier switch signal output
ROTC	Output	P83	Chroma rotation signal output
ENV	Input	P90	Envelope signal input
SI1	Input	P63	Serial data input (serial interface channel 1)
SO1	Output	P62	Serial data output (serial interface channel 1)
SCK1	I/O	P61/BUZ	Serial clock I/O (serial interface channel 1)
SI2	Input	BUSY	Serial data input (serial interface channel 2)
SO2	Output	-	Serial data output (serial interface channel 2)
SCK2	I/O	-	Serial clock I/O (serial interface channel 2)
BUSY	Input	SI2	Serial busy signal input (serial interface channel 2)
STRB	Output	P60/CLO	Serial strobe signal output (serial interface channel 2)
ANI0 to ANI7	Analog input	P70 to P77	Analog signal input of A/D converter
ANI8 to ANI11		-	
CTLIN	-	-	CTL amplifier input capacitor connection
CTLOUT1	Output	-	CTL amplifier output
CTLOUT2	I/O	-	Logic signal input/CTL amplifier output
RECCTL+, RECCTL-	I/O	-	RECCTL signal output/PBCTL signal input
CTLDLY	-	-	External time constant connection (for RECCTL rewriting)
VREFC	-	-	VREF amplifier AC connection
NMI	Input	-	Non-maskable interrupt request input
INTP0 to INTP2	Input	-	External interrupt request input
INTP3	Input	REEL0IN	
KEY0 to KEY4	Input	P91 to P95	Key input signal input
CLO	Output	P60/STRB	Clock output
BUZ	Output	P61/SCK1	Buzzer output

2.2 Non-Port Pins (2/2)

Pin Name	I/O	Alternate Function	Function
HWIN	Input	P65	External input of hardware watch counter
RESET	Input	-	Reset input
X1	Input	-	Crystal connection for main system clock oscillation
X2	-		
XT1	Input	-	Crystal connection for subsystem clock oscillation.
XT2	-		Crystal connection for watch clock oscillation
AV _{DD1} , AV _{DD2}	-	-	Positive power supply to analog circuits
AV _{SS1} , AV _{SS2}	-	-	GND of analog circuits
AV _{REF}	-	-	Reference voltage input to A/D converter
V _{DD}	-	-	Positive power supply to digital circuits
V _{SS}	-	-	GND of digital circuits
IC	-	-	Internally connected. Directly connect to V _{SS} .

2.3 I/O Circuits and Connection of Unused Pins

Table 2-1 shows the I/O circuit type of each pin and the recommended connection of unused pins. For the configuration of each type of I/O circuit, refer to Figure 2-1.

Table 2-1. I/O Circuit Type of each Pin and Recommended Connection of Unused Pins (1/2)

Pin	I/O Circuit Type	I/O	Recommended Connection of Unused Pins	
P00 to P07	5-A	I/O	Input: Connect to V _{DD} Output: Leave open	
P40 to P47				
P50 to P57				
P60/STRB/CLO				
P61/SCK1/BUZ	8-A			
P62/SO1	5-A			
P63/SI1	8-A			
P64	5-A			
P65/HWIN	8-A			
P66/PWM4	5-A			
P67/PWM5				
P70/ANI0 to P77/ANI7	9	Input	Connect to V _{SS}	
P80	5-A	I/O	Input: Connect to V _{DD} Output: Leave open	
P82/HASW				
P83/ROTC				
P84/PWM2				
P85/PWM3				
P86/PTO10				
P87/PTO11				
P90/ENV				
P91/KEY0 to P95/KEY4				8-A
P96				5-A
SI2/BUSY	2-A	Input	Connect to V _{DD}	
SO2	4	Output	Hi-Z: Connect to V _{SS} via a pull-down resistor Others: Leave open	
SCK2	8-A	I/O	Input: Connect to V _{DD} Output: Leave open	
ANI8 to ANI11	7	Input	Connect to V _{SS}	
RECCTL+, RECCTL-	—	I/O	When ENCTL = 0 and ENREC = 0: Connect to V _{SS}	

Remark ENCTL : bit 1 of amplifier control register (AMPC)
ENREC: bit 7 of amplifier mode register 0 (AMPM0)

Table 2-1. I/O Circuit Type of each Pin and Recommended Connection of Unused Pins (2/2)

Pin	I/O Circuit Type	I/O	Recommended Connection of Unused Pins
DFGIN	—	Input	When ENDRUM = 0: Connect to V _{SS}
DPGIN			When ENDRUM = 0 or ENDRUM = 1 and SELPGSEPA = 0: Connect to V _{SS}
CFGIN, CFGCPIN			When ENCAP = 0: Connect to V _{SS}
CSYNCIN			When ENCSYN = 0: Connect to V _{SS}
REEL0IN/INTP3, REEL1IN			When ENREEL = 0: Connect to V _{SS}
CTLOUT1	—	Output	Leave open
CTLOUT2	—	I/O	When ENCTL = 0 and ENCOMP = 0: Connect to V _{SS} When ENCTL = 1: Leave open
CFGAMPO	—	Output	Leave open
CTLIN	—	—	When ENCTL = 0: Leave open
VREFC			When ENCTL = 0 and ENCAP = 0 and ENCOMP = 0: Leave open
CTLDLY			Leave open
PWM0, PWM1	3	Output	Leave open
PTO00 to PTO02			
NMI	2	Input	Connect to V _{DD}
INTP0			Connect to V _{DD} or V _{SS}
INTP1, INTP2	2-A	Input	Connect to V _{DD}
AV _{DD1} , AV _{DD2}	—	—	Connect to V _{DD}
AV _{REF} , AV _{SS1} , AV _{SS2}			Connect to V _{SS}
RESET	2	—	—
XT1	—	—	Connect to V _{SS}
XT2			Leave open
IC			Directly connect to V _{SS}

Remark ENDRUM : bit 2 of amplifier control register (AMPC)
 SELPGSEPA: bit 2 of amplifier mode register 0 (AMPM0)
 ENCAP : bit 3 of amplifier control register (AMPC)
 ENCSYN : bit 5 of amplifier control register (AMPC)
 ENREEL : bit 6 of amplifier control register (AMPC)
 ENCTL : bit 1 of amplifier control register (AMPC)
 ENCOMP : bit 4 of amplifier control register (AMPC)

Figure 2-1. I/O Circuits of Pins (1/2)

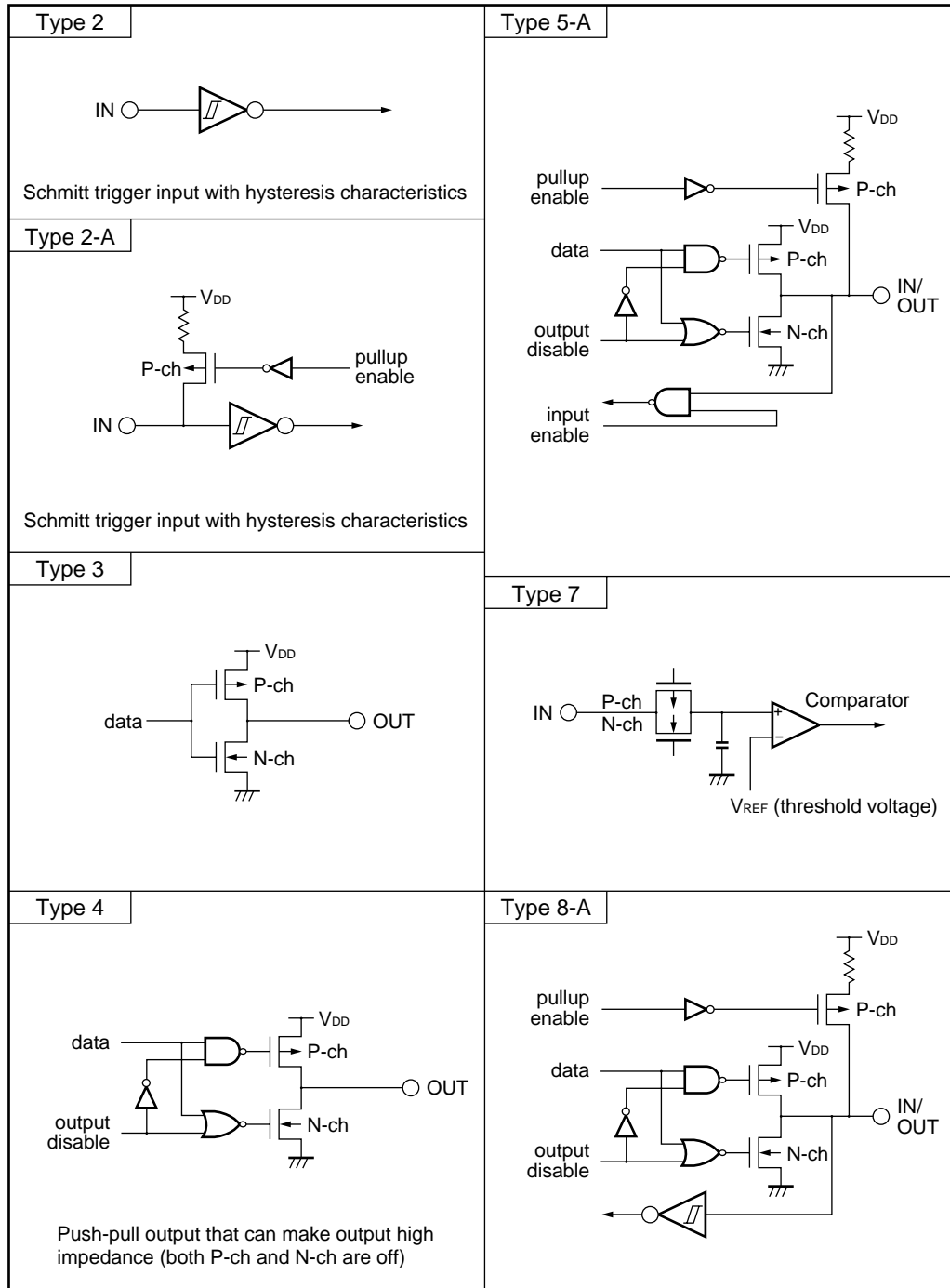
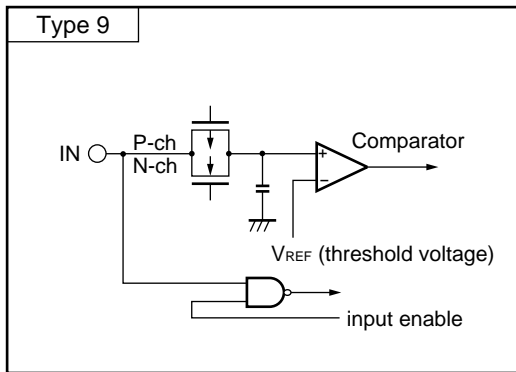

Figure 2-1. I/O Circuits of Pins (2/2)



3. INTERNAL BLOCK FUNCTIONS

3.1 CPU Registers

3.1.1 General-purpose registers

The μPD784916B has eight banks of general-purpose registers. One bank consists of sixteen 8-bit general-purpose registers. Two of these 8-bit registers can be used in pairs as a 16-bit register. Four of the 16-bit general-purpose registers can be used to specify a 24-bit address in combination with an 8-bit address expansion register.

These eight banks of general-purpose registers can be selected by software or context switching function.

The general-purpose registers, except for the address expansion registers V, U, T, and W, are mapped to the internal RAM.

Figure 3-1. Configuration of General-Purpose Registers

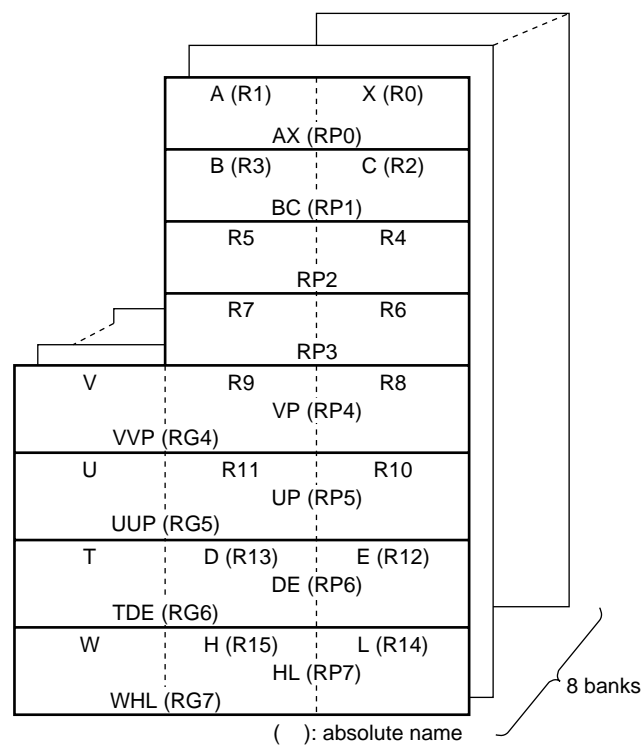

Caution Although R4, R5, R6, R7, RP2, and RP3 can be used as X, A, C, B, AX, and BC registers, respectively, by setting the RSS bit of PSW to 1, do not use this function. The function of the RSS bit is planned to be deleted from the future models in the 78K/IV Series.

3.1.2 Other CPU registers

(1) Program counter

The program counter of the μPD784916B is 20 bits wide. The value of the program counter is automatically updated as the program is executed.

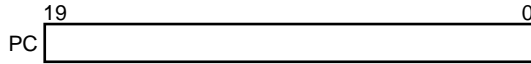

(2) Program status word

This is a register that holds the various statuses of the CPU. Its contents are automatically updated as the program is executed.

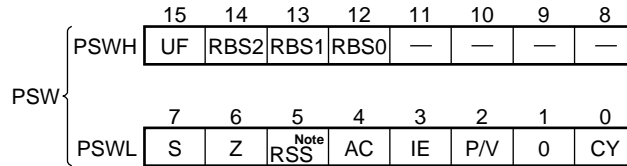

Note The RSS flag is provided to maintain compatibility with the microcontrollers in the 78K/III Series. Always set this flag to 0 except when the software of the 78K/III Series is used.

(3) Stack pointer

This is a 24-bit pointer that holds the first address of the stack. Be sure to write 0 to the high-order 4 bits.

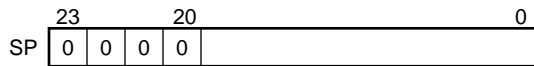

3.2 Memory Space

The μPD784916B can access a 64 Kbyte memory space. Table 3-1 shows the addresses of the internal ROM and internal data areas.

Table 3-1. Memory Space

Part Number	Internal ROM Area	Internal Data Area
μPD784915B	0000H-BFFFH	FA00H-FFFFH
μPD784916B	0000H-F7FFH	

Caution Some products in the 78K/IV Series can access up to 1 Mbyte of memory space in an address expansion mode which is set by the LOCATION instruction. However, the memory space of the μPD784916B is 64 Kbytes (0000H to FFFFH). Therefore, be sure to execute the LOCATION 0 instruction immediately after reset to set the memory space to 64 Kbytes (the LOCATION instruction cannot be used more than twice).

Figure 3-2. Memory Map of μPD784915B

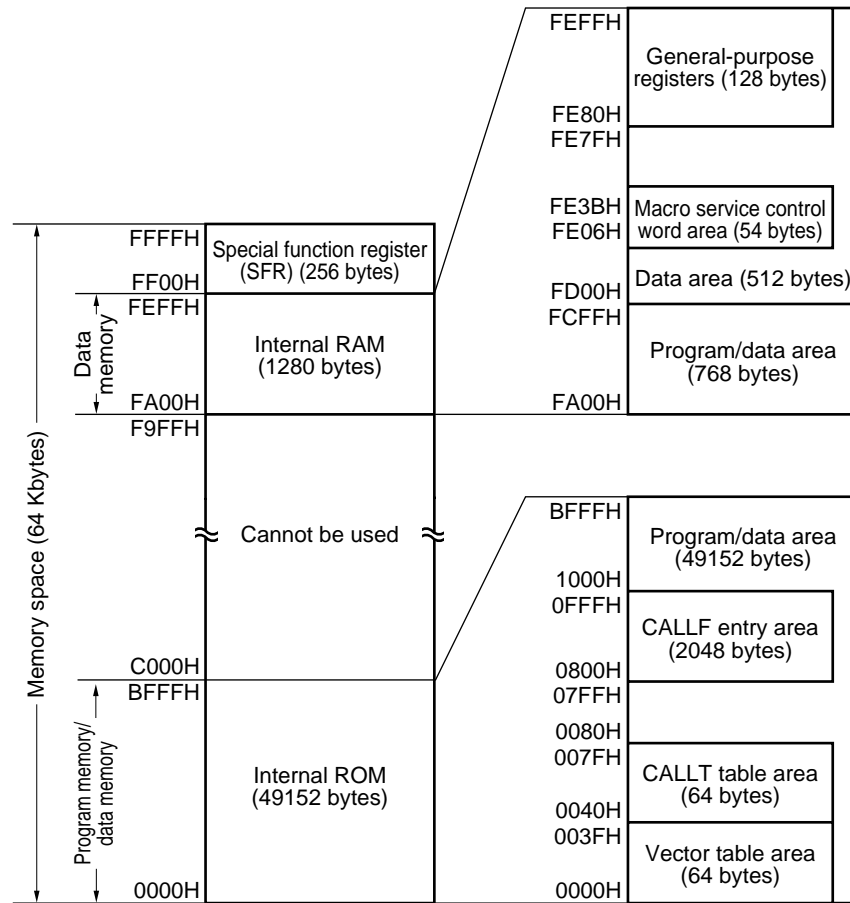
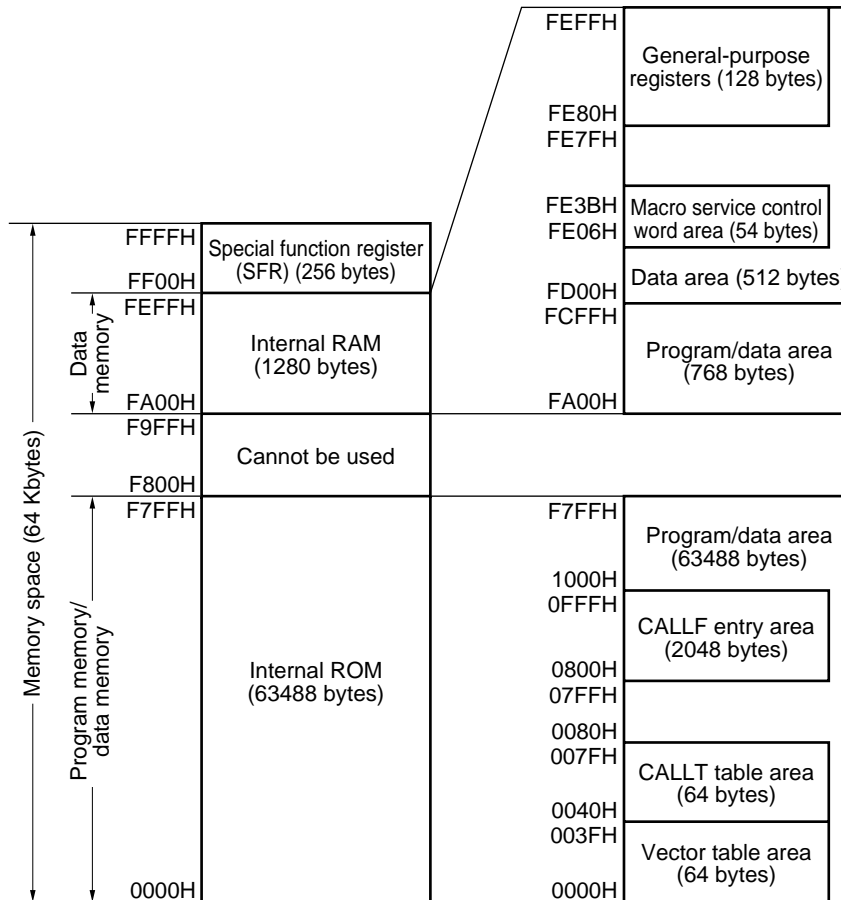

Figure 3-3. Memory Map of μPD784916B



3.3 Special Function Registers (SFRs)

Special function registers are assigned special functions and mapped to a 256-byte space from addresses FF00H through FFFFH. These registers include mode registers and control registers that control the internal peripheral hardware units.

Caution Do not access an address to which no SFR is assigned. If such an address is accessed by mistake, the μPD784916B may be deadlocked. This deadlock can be cleared only by reset input.

Table 3-2 lists the special function registers (SFRs). The meanings of the symbols in this table are as follows:

- Abbreviation Abbreviation of an SFR. This abbreviation is reserved for NEC's assembler (RA78K4). With a C compiler (CC78K4), the abbreviation can be used as an sfr variable by the #pragma sfr instruction.
- R/W Indicates whether the SFR in question can be read or written.
 - R/W : Read/write
 - R : Read only
 - W : Write only
- Bit length Indicates the bit length (word length) of the SFR.
- Bit units for manipulation Indicates bit units in which the SFR in question can be manipulated. An SFR that can be manipulated in 16-bit units can be described as the operand sfrp of an instruction. Specify an even address to manipulate this SFR.
An SFR that can be manipulated in 1-bit units can be described for a bit manipulation instruction.
- After reset Indicates the status of each register after the $\overline{\text{RESET}}$ signal has been input.

Table 3-2. Special Function Registers (1/4)

Address	Special Function Register (SFR) Name	Symbol	R/W	Bit Length	Bit Units for Manipulation			After Releasing Reset	
					1 bit	8 bits	16 bits		
FF00H	Port 0	P0	R/W	8	√	√	-	Undefined	
FF04H	Port 4	P4		8	√	√	-		
FF05H	Port 5	P5		8	√	√	-		
FF06H	Port 6	P6		8	√	√	-		
FF07H	Port 7	P7	R	8	√	√	-		
FF08H	Port 8	P8	R/W	8	√	√	-		
FF09H	Port 9	P9		8	√	√	-		
FF0EH	Port 0 buffer register L	P0L		8	√	√	-		
FF0FH	Port 0 buffer register H	P0H		8	√	√	-		
FF10H	Timer 0 compare register 0	CR00	R/W	16	-	-	√	Cleared to 0	
FF11H	Event counter compare register 0	ECC0		W	8	-	√		-
FF12H	Timer 0 compare register 1	CR01		W	16	-	-		√
FF13H	Event counter compare register 1	ECC1		W	8	-	√		-
FF14H	Timer 0 compare register 2	CR02		W	16	-	-		√
FF15H	Event counter compare register 2	ECC2		W	8	-	√		-
FF16H	Timer 1 compare register 0	CR10		W	16	-	-		√
FF17H	Event counter compare register 3	ECC3		W	8	-	√		-
FF18H	Timer 1 compare register 1	CR11		W	16	-	-		√
FF1AH	Timer 1 compare register 2	CR12	R	16	-	-	√		
FF1CH	Timer 1 compare register 3	CR13	R/W	16	-	-	√		
FF1EH	Timer 2 compare register 0	CR20		16	-	-	√		
FF20H	Port 0 mode register	PM0	W	8	-	√	-	FFH	
FF24H	Port 4 mode register	PM4		8	-	√	-		
FF25H	Port 5 mode register	PM5		8	-	√	-		
FF26H	Port 6 mode register	PM6		8	-	√	-		
FF28H	Port 8 mode register	PM8		8	-	√	-	FDH	
FF29H	Port 9 mode register	PM9		8	-	√	-	7FH	
FF2EH	Real-time output port 0 control register	RTPC	R/W	8	√	√	-	00H	
FF30H	Timer register 0	TM0	R	16	-	-	√	Cleared to 0	
FF31H	Event counter	EC	R/W	8	-	√	-		
FF32H	Timer register 1	TM1	R	16	-	-	√		
FF34H	Free running counter (bits 0 to 15)	FRCL	R/W	16	-	-	√	0000H	
FF35H	Free running counter (bits 16 to 21)	FRCH		8	-	√	-	00H	
FF36H	Timer register 2	TM2		16	-	-	√	Cleared to 0	
FF38H	Timer control register 0	TMC0	R/W	8	√	√	-	00H	
FF39H	Timer control register 1	TMC1		8	√	√	-		
FF3AH	Timer control register 2	TMC2		8	√	√	-		
FF3BH	Timer control register 3	TMC3		8	√	√	-	00×00000	

Remark Cleared to 0: Counter is initialized to 0 within 16 clocks after the reset signal has been deasserted (the contents before initialization are undefined).

Table 3-2. Special Function Registers (2/4)

Address	Special Function Register (SFR) Name	Symbol	R/W	Bit Length	Bit Units for Manipulation			After Releasing Reset	
					1 bit	8 bits	16 bits		
FF3CH	Timer register 3	TM3	R	16	–	–	√	Cleared to 0	
FF3DH	Timer control register 4	TMC4	R/W	8	√	√	–	xx000000	
FF3EH	Timer register 4	TM4	R	16	–	–	√	Cleared to 0	
FF48H	Port 8 mode control register	PMC8	R/W	8	√	√	–	00H	
FF4DH	Trigger source select register	TRGS0		8	√	√	–		
FF4EH	Pull-up resistor option register L	PUOL		8	√	√	–		
FF4FH	Pull-up resistor option register H	PUOH		8	√	√	–		
FF50H	Input control register	ICR		8	√	√	–		10H
FF51H	Up/down counter count register	UDC		8	–	√	–		Undefined
FF52H	Event divider counter	EDV		R	8	–	√		–
FF53H	Capture mode register	CPTM	R/W	8	√	√	–	00H	
FF54H	Timer register 5	TM5	R	16	–	–	√	Cleared to 0	
FF56H	Timer 3 capture register 0	CPT30		16	–	–	√		
FF58H	Timer 0 output mode register	TOM0	W	8	–	√	–	xx000000	
FF59H	Timer 0 output control register	TOC0		8	–	√	–	00H	
FF5AH	Timer 1 output mode register	TOM1 ^{Note 1}	R/W	8	–	√	–	80H	
FF5BH	Timer 1 output control register	TOC1	W	8	–	√	–	00H	
FF5CH	Timer 3 compare register 0	CR30	R/W	16	–	–	√	Cleared to 0	
FF5EH	Timer 3 compare register 1	CR31		16	–	–	√		
FF60H	Port 8 buffer register L	P8L		8	√	√	–	000x0x0x	
FF63H	Up/down counter compare register	UDCC	W	8	–	√	–	Undefined	
FF65H	Trigger source select register 1	TRGS1	R/W	8	√	√	–	00H	
FF66H	Port 6 mode control register	PMC6		8	√	√	–		
FF68H	A/D converter mode register	ADM		16	–	–	√		0000H
		ADML ^{Note 2}	8	√	√	–			
FF6AH	A/D conversion result register	ADCR	R	8	–	√	–	Undefined	
FF6CH	Hardware watch counter 0	HW0	R/W	16	–	–	√	Not affected by reset	
FF6EH	Hardware watch counter 1	HW1	R	16	–	–	√		
FF6FH	Watch mode register	WM	R/W	8	√	√	–	00xx0x00	
FF70H	PWM control register 0	PWMC0	R/W	8	√	√	–	05H	
FF71H	PWM control register 1	PWMC1		8	√	√	–	15H	
FF72H	PWM0 modulo register	PWM0		16	–	–	√	0000H	
FF73H	PWM2 modulo register	PWM2		8	–	√	–	00H	
FF74H	PWM1 modulo register	PWM1		16	–	–	√	0000H	
FF75H	PWM3 modulo register			8	–	√	–	00H	

Notes 1. When the timer 1 output mode register (TOM1) is read, the write sequence of the REC driver is read (bits 0 and 1).

2. ADML is the low-order 8 bits of the A/D converter mode register (ADM) and can be manipulated in 1- or 8-bit units.

Remark Cleared to 0: Counter is initialized to 0 within 16 clocks after the reset signal has been deasserted (the contents before initialization are undefined).

Table 3-2. Special Function Registers (3/4)

Address	Special Function Register (SFR) Name	Symbol	R/W	Bit Length	Bit Units for Manipulation			After Releasing Reset		
					1 bit	8 bits	16 bits			
FF76H	PWM5 modulo register	PWM5	R/W	16	–	–	√	0000H		
FF77H	PWM4 modulo register	PWM4		8	–	√	–	00H		
FF78H	Event divider control register	EDVC	W	8	–	√	–	00H		
FF79H	Clock output mode register	CLOM	R/W	8	√	√	–	00H		
FF7AH	Timer 4 capture/compare register 0	CR40		16	–	–	√	Cleared to 0		
FF7BH	Clock control register	CC		8	√	√	–	00H		
FF7CH	Timer 4 capture register 1	CR41	R	16	–	–	√	Cleared to 0		
FF7DH	Capture/compare control register	CRC	W	8	–	√	–	00H		
FF7EH	Timer 5 compare register	CR50	R/W	16	–	–	√	Cleared to 0		
FF84H	Serial mode register 1	CSIM1		8	√	√	–	00H		
FF85H	Serial shift register 1	SIO1		8	–	√	–	Undefined		
FF88H	Serial mode register 2	CSIM2		8	√	√	–	00H		
FF89H	Serial shift register 2	SIO2		8	–	√	–	Undefined		
FF8AH	Serial control register 2	CSIC2		8	–	√	–	00H		
FF91H	Head amplifier switch output control register	HAPC		8	√	√	–			
FF94H	Amplifier control register	AMPC		8	√	√	–			
FF95H	Amplifier mode register 0	AMPM0		8	√	√	–			
FF96H	Amplifier mode register 1	AMPM1		8	√	√	–			
FF97H	Gain control register	CTLM		8	√	√	–			
FFA0H	External interrupt mode register	INTM0		8	√	√	–		000000×0	
FFA1H	External capture mode register 1	INTM1		8	√	√	–	00H		
FFA2H	External capture mode register 2	INTM2		8	√	√	–	70H		
FFA6H	Key interrupt control register	KEYC		8	√	√	–			
FFA8H	In-service priority register	ISPR		R	8	√	√		–	00H
FFAAH	Interrupt mode control register	IMC		R/W	8	√	√		–	80H
FFACH	Interrupt mask flag register	MK0L	MK0		8	√	√		√	FFH
FFADH		MK0H			8	√	√			
FFAEH		MK1L	MK1		8	√	√	√		
FFAFH		MK1H			8	√	√			
FFB0H		FRC capture register 0L	CPT0L	R	16	–	–	√	Cleared to 0	
FFB1H	FRC capture register 0H	CPT0H	8		–	√	–			
FFB2H	FRC capture register 1L	CPT1L	16		–	–	√			
FFB3H	FRC capture register 1H	CPT1H	8		–	√	–			
FFB4H	FRC capture register 2L	CPT2L	16		–	–	√			
FFB5H	FRC capture register 2H	CPT2H	8		–	√	–			
FFB6H	FRC capture register 3L	CPT3L	16		–	–	√			
FFB7H	FRC capture register 3H	CPT3H	8		–	√	–			
FFB8H	FRC capture register 4L	CPT4L	16		–	–	√			

Remark Cleared to 0: Counter is initialized to 0 within 16 clocks after the reset signal has been deasserted (the contents before initialization are undefined).

Table 3-2. Special Function Registers (4/4)

Address	Special Function Register (SFR) Name	Symbol	R/W	Bit Length	Bit Units for Manipulation			After Releasing Reset
					1 bit	8 bits	16 bits	
FFB9H	FRC capture register 4H	CPT4H	R	8	–	√	–	Cleared to 0
FFBAH	FRC capture register 5L	CPT5L		16	–	–	√	
FFBBH	FRC capture register 5H	CPT5H		8	–	√	–	
FFC0H	Standby control register	STBC	R/W	8	–	√	–	0000×000
FFC4H	Execution speed select register	MM	W	8	–	√	–	20H
FFCEH	CPU clock status register	PCS	R	8	√	√	–	00H
FFCFH	Oscillation stabilization time specification register	OSTS	W	8	–	√	–	43H
FFE0H	Interrupt control register (INTP0)	PIC0	R/W	8	√	√	–	
FFE1H	Interrupt control register (INTCPT3)	CPTIC3		8	√	√	–	
FFE2H	Interrupt control register (INTCPT2)	CPTIC2		8	√	√	–	
FFE3H	Interrupt control register (INTCR12)	CRIC12		8	√	√	–	
FFE4H	Interrupt control register (INTCR00)	CRIC00		8	√	√	–	
FFE5H	Interrupt control register (INTCLR1)	CLRIC1		8	√	√	–	
FFE6H	Interrupt control register (INTCR10)	CRIC10		8	√	√	–	
FFE7H	Interrupt control register (INTCR01)	CRIC01		8	√	√	–	
FFE8H	Interrupt control register (INTCR02)	CRIC02		8	√	√	–	
FFE9H	Interrupt control register (INTCR11)	CRIC11		8	√	√	–	
FFEAH	Interrupt control register (INTCPT1)	CPTIC1		8	√	√	–	
FFEBH	Interrupt control register (INTCR20)	CRIC20		8	√	√	–	
FFEDH	Interrupt control register (INTTB)	TBIC		8	√	√	–	
FFEEH	Interrupt control register (INTAD)	ADIC		8	√	√	–	
FFE FH	Interrupt control register (INTP2) ^{Note}	PIC2		8	√	√	–	
	Interrupt control register (INTCR40) ^{Note}	CRIC40						
FFF0H	Interrupt control register (INTUDC)	UDCIC		8	√	√	–	
FFF1H	Interrupt control register (INTCR30)	CRIC30		8	√	√	–	
FFF2H	Interrupt control register (INTCR50)	CRIC50		8	√	√	–	
FFF3H	Interrupt control register (INTCR13)	CRIC13		8	√	√	–	
FFF4H	Interrupt control register (INTCSI1)	CSIIC1		8	√	√	–	
FFF5H	Interrupt control register (INTW)	WIC		8	√	√	–	
FFF7H	Interrupt control register (INTP1)	PIC1		8	√	√	–	
FFF8H	Interrupt control register (INTP3)	PIC3		8	√	√	–	
FFFAH	Interrupt control register (INTCSI2)	CSIIC2		8	√	√	–	

Note PIC2 and CRIC40 are at the same address (register).

Remark Cleared to 0: Counter is initialized to 0 within 16 clocks after the reset signal has been deasserted (the contents before initialization are undefined).

3.4 PORTS

The μPD784916B is provided with the ports shown in Figure 3-4. Table 3-3 shows the function of each port.

Figure 3-4. Port Configuration

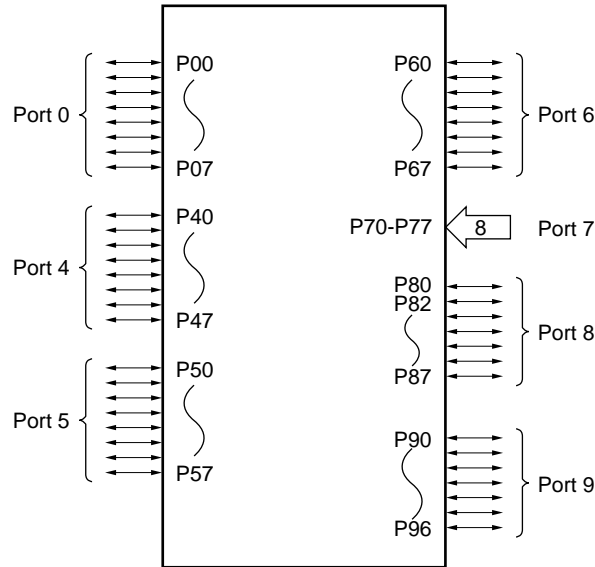

Table 3-3. Port Function

Name	Pin Name	Function	Specification of Pull-up Resistor
Port 0	P00 to P07	Can be set in input or output mode in 1-bit units.	Pull-up resistors are connected to all pins in input mode.
Port 4	P40 to P47		
Port 5	P50 to P57		
Port 6	P60 to P67		
Port 7	P70 to P77	Input port	Pull-up resistor is not provided.
Port 8	P80, P82 to P87	Can be set in input or output mode in 1-bit units.	Pull-up resistors are connected to all pins in input mode.
Port 9	P90 to P96		

3.5 Real-time Output Port

A real-time output port consists of a port output latch and a buffer register (refer to **Figure 3-5**).

The function to transfer the data prepared in advance in the buffer register to the output latch when a trigger such as a timer interrupt occurs, and output the data to an external device is called a real-time output function. A port used in this way is called a real-time output port (RTP).

Table 3-4 shows the real-time output ports of the μPD784916B.

Table 3-5 shows the trigger sources of RTPs.

Figure 3-5. Configuration of RTP

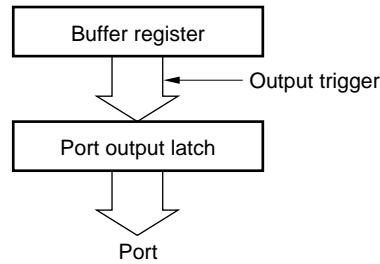

Table 3-4. Bit Configuration of RTP

RTP	Alternate Function	Number of Bits of Real-Time Output Data	Number of Bits That Can Be Specified as RTP	Remark
RTP0	Port 0	4 bits × 2 channels or 8 bits × 1 channel	4-bit units	—
RTP8	Port 8	1 bit × 1 channel and 2 bits × 1 channel	1-bit units	Pseudo V _{SYNC} output : 1 channel (RTP80) Head amplifier switch : 1 channel (RTP82) Chrominance rotation signal output: 1 channel (RTP83)

Table 3-5. Trigger Sources of RTP

Trigger Source		INTCR00	INTCR01	INTCR02	INTCR13	INTCR50	INTP0	Remark
RTP0	High-order 4 bits		√					
	Low-order 4 bits			√			√	
	All 8 bits			√			√	
RTP8	Bit 0		√	√	√	√		Note 1
	Bits 2 and 3	√						Note 2

Notes 1. Select one of the four trigger sources.

- When the real-time output port mode is set by the port mode control register 8 (PMC8), the HASW and ROT-C signals that are set by the head amplifier switch output control register (HAPC) are directly output. The HASW and ROT-C signals are synchronized with HSW output (TM0-CR00 coincidence signal). However, the set signal is output immediately when the HAPC register is rewritten.

Figures 3-6 and 3-7 show the block diagrams of RTP0 and RTP8.
 Figure 3-8 shows the types of RTP output trigger sources.

Figure 3-6. Block Diagram of RTP0

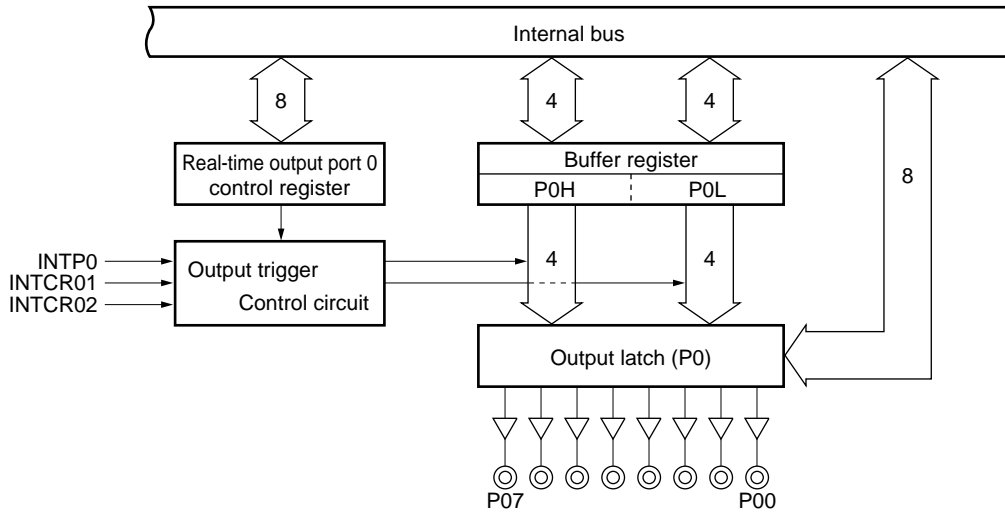

Remark INTCR01: TM0-CR01 coincidence signal
 INTCR02: TM0-CR02 coincidence signal

Figure 3-7. Block Diagram of RTP8

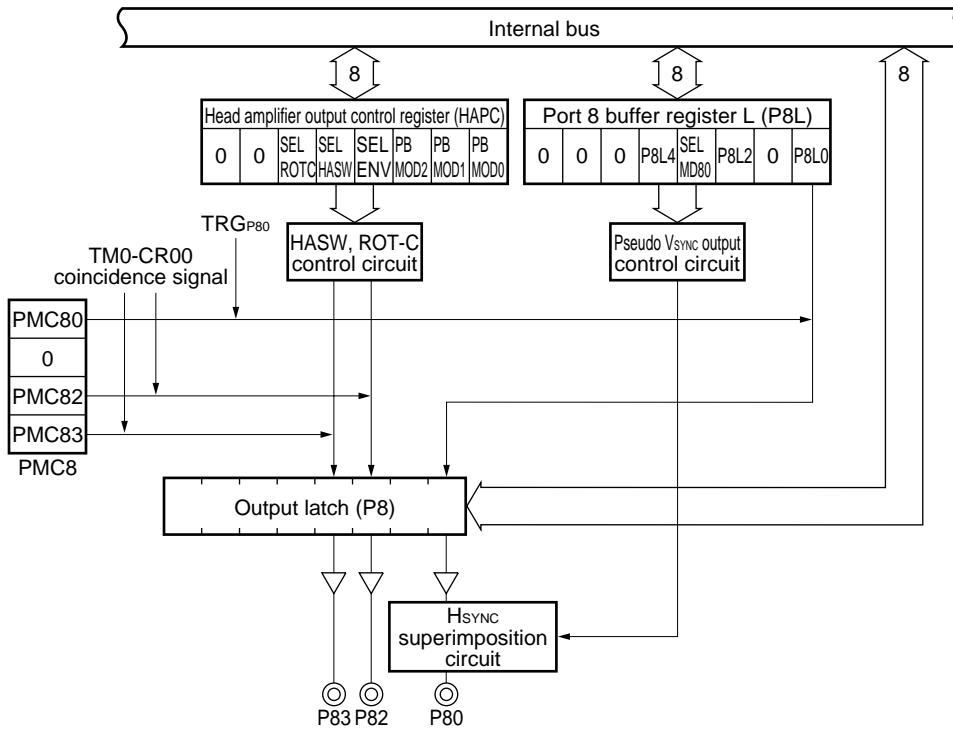
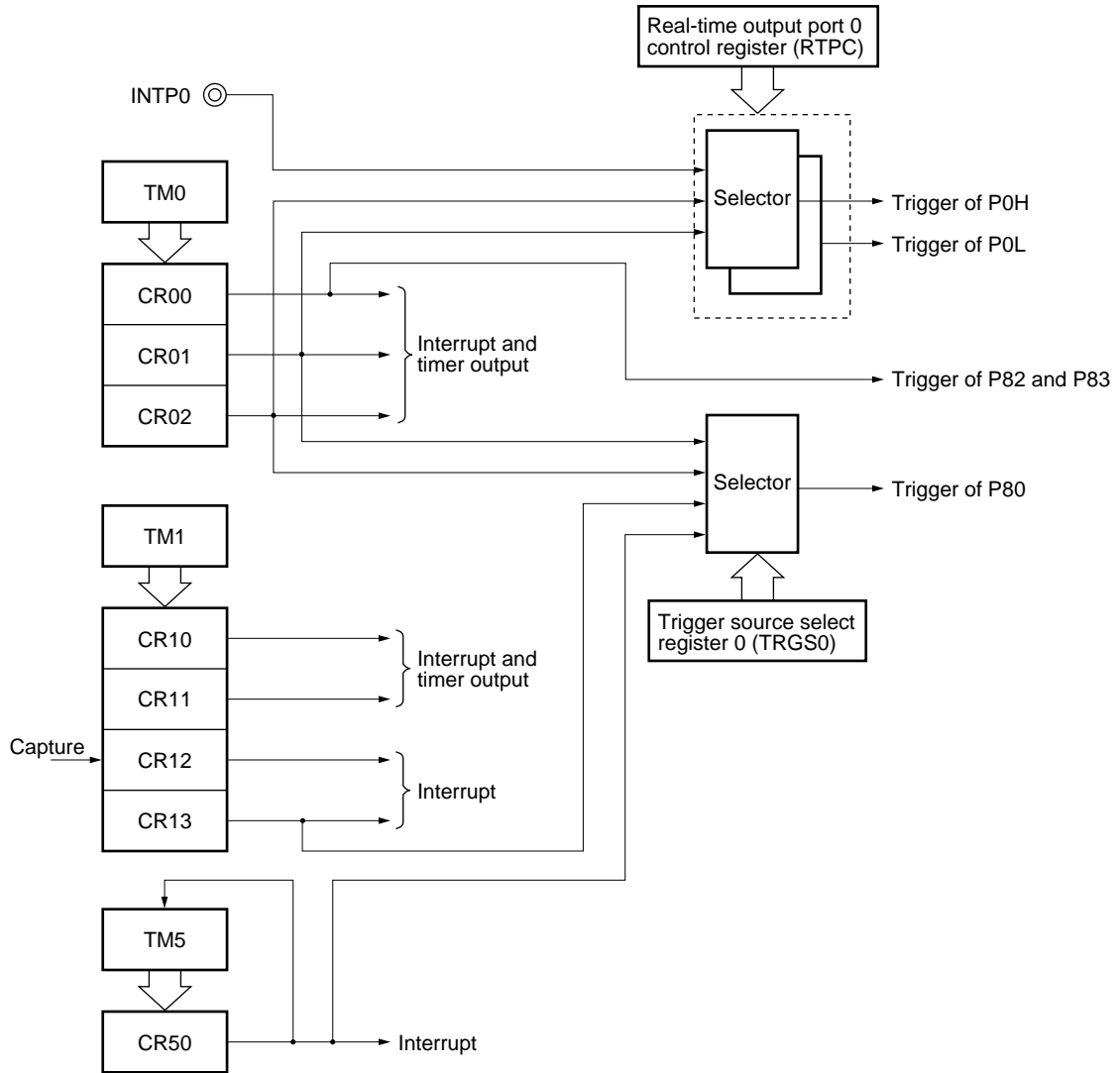

Figure 3-8. Types of RTP Output Trigger Sources



RTP80 can output low-level, high-level, and high-impedance values real-time.

Because RTP80 can superimpose a horizontal sync signal, it can be used to create a pseudo vertical sync signal. When RTP80 is set in the pseudo V_{SYNC} output mode, it repeatedly outputs a specific pattern when an output trigger occurs.

Figure 3-9 shows the operation timing of RTP80.

Figure 3-9. Example of Operation Timing of RTP80

(a) When H_{SYNC} signal is superimposed

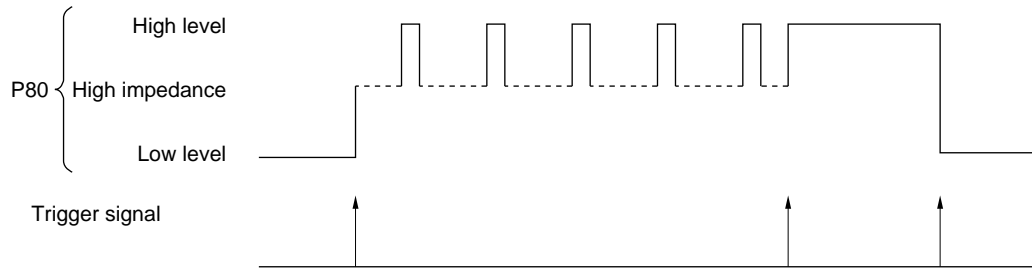

(b) Pseudo V_{SYNC} output mode

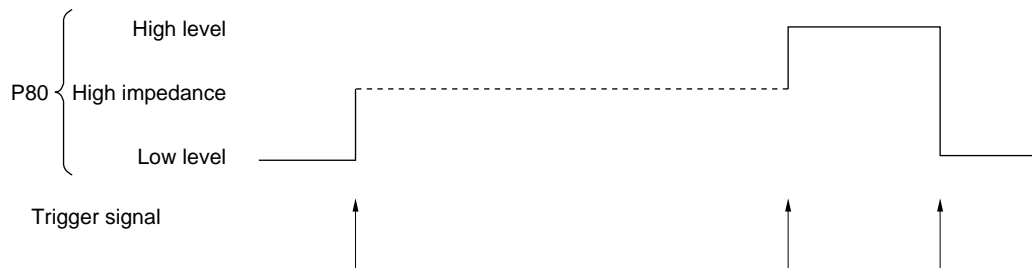

3.6 Super Timer Unit

The μPD784916B is provided with a super timer unit that consists of the timers shown in Table 3-6.

Table 3-6. Configuration of Super Timer Unit

Unit Name	Timer/Counter	Resolution	Maximum Count Time	Register	Remark
Timer 0	TM0 (16-bit timer)	1 μs	65.5 ms	CR00	Controls delay of video head switching signal
				CR01	Controls delay of audio head switching signal
CR02				Controls pseudo V _{SYNC} output timing	
	EC (8-bit counter)	-	-	ECC0, ECC1, ECC2, ECC3	Creates internal head switching signal
Free running counter	FRC (22-bit counter)	125 ns	524 ms	CPT0	Detects reference phase (to control drum phase)
				CPT1	Detects phase of drum motor (to control drum phase)
				CPT2	Detects speed of drum motor (to control drum speed)
				CPT3	Detects speed of capstan motor (to control speed of capstan motor)
				CPT4, CPT5	Detects remaining tape for reel FG
Timer 1	TM1 (16-bit timer)	1 μs	65.5 ms	CR10	Playback: Creates internal reference signal Recording: Buffer oscillator in case V _{SYNC} is missing
				CR11	Controls RECCTL output timing
				CR12	Detects phase of capstan motor (to control capstan phase)
				CR13	Controls V _{SYNC} mask as noise prevention measures
	TM3 (16-bit timer)	1 μs or 1.1 μs	65.5 ms or 71.5 ms	CR30, CR31	Controls duty detection timing of PBCTL signal
	EDV (8-bit counter)	-	-	CPT30 EDVC	Measures cycle of PBCTL signal Divides CFG signal frequency
Timer 2	TM2 (16-bit timer)	1 μs	65.5 ms	CR20	Can be used as interval timer (to control system)
Timer 4	TM4 (16-bit timer)	2 μs	131 ms	CR40	Detects duty of remote controller signal (to decode remote controller signal)
				CR41	Measures cycle of remote controller signal (to decode remote controller signal)
Timer 5	TM5 (16-bit timer)	2 μs	131 ms	CR50	Can be used as interval timer (to control system)
Up/down counter	UDC (5-bit counter)	-	-	UDCC	Creates linear tape counter
PWM output unit	-	-	-	PWM0, PWM1, PWM5	16-bit resolution (carrier frequency: 62.5 kHz)
				PWM2, PWM3, PWM4	8-bit resolution (carrier frequency: 62.5 kHz)

(1) Timer 0 unit

Timer 0 unit creates head switching signal and pseudo V_{SYNC} output timing from the PG and FG signals of the drum motor.

This unit consists of an event counter (EC: 8 bits), four compare registers (ECC0 to ECC3), a timer (TM0: 16 bits), and three compare registers (CR00 to CR02).

A signal indicating coincidence between the value of timer 0 and the value of a compare register can be used as the output trigger of the real-time output port.

(2) Free running counter unit

The free running counter unit detects the speed and phase of the drum motor, and the speed and reel speed of the capstan motor.

This unit consists of a free running counter (FRC), six capture registers (CPT0 to CPT5), a V_{SYNC} separation circuit, and a H_{SYNC} separation circuit.

(3) Timer 1 unit

Timer 1 unit is a reference timer unit synchronized with the frame cycle and creates the RECCTL signal, detects the phase of the capstan motor, and detects the duty factor of the PBCTL signal. This unit consists of the following three groups.

- Timer 1 (TM1), compare registers (CR10, CR11, and CR13), and capture register (CR12)
- Timer 3 (TM3), compare registers (CR30 and CR31), and capture register (CPT30)
- Event divider counter (EDV) and compare register (EDVC)

The TM1-CR13 coincidence signal can be used for automatic unmasking of V_{SYNC} or as the output trigger of the real-time output port.

Figure 3-10. Block Diagram of Super Timer Unit (TM0, FRC, TM1)

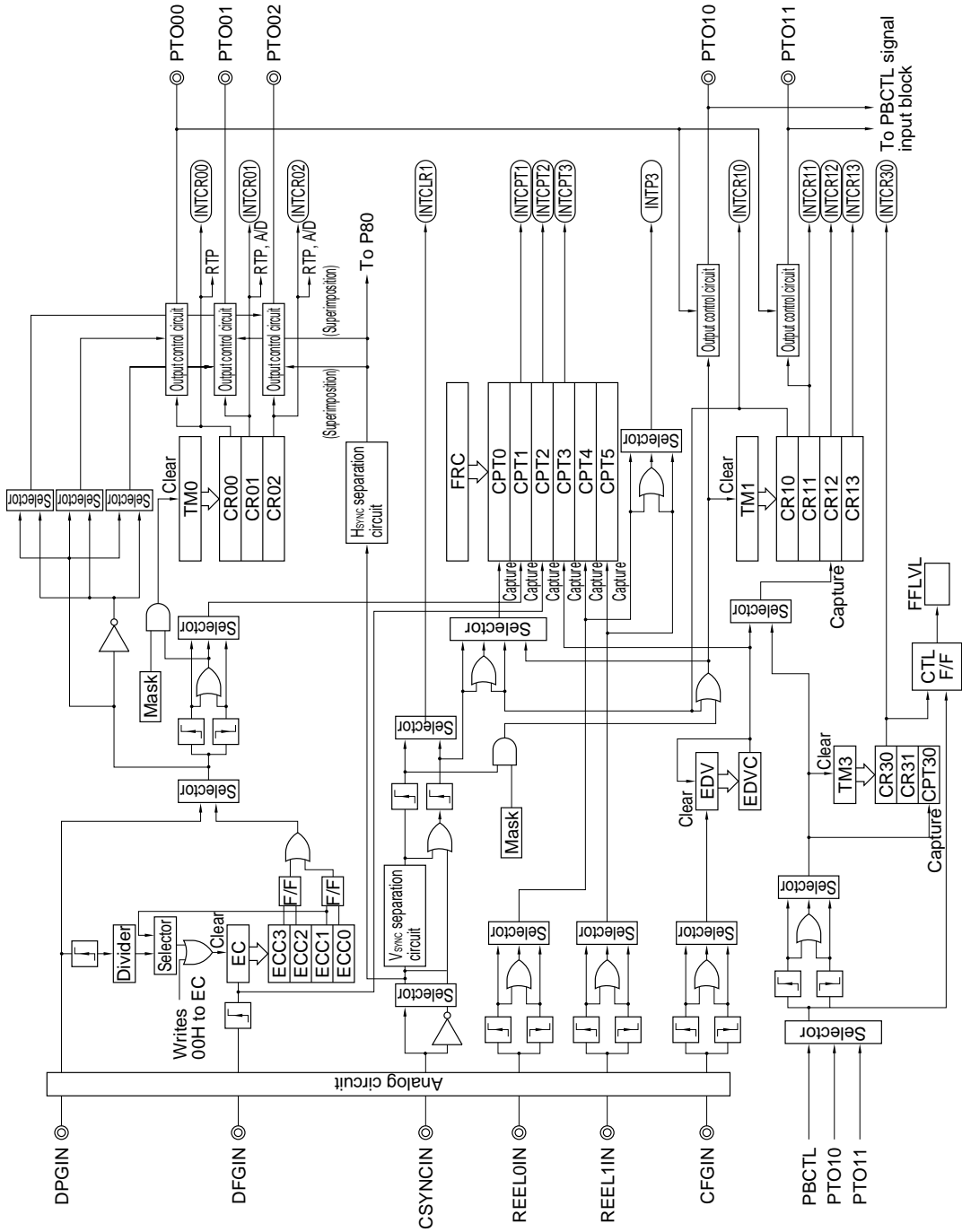

(4) Timer 2 unit

Timer 2 unit is a general-purpose 16-bit timer unit.

This unit consists of a timer 2 (TM2) and a compare register (CR20).

The timer is cleared when the TM2-CR20 coincidence signal occurs, and at the same time, an interrupt request is generated.

Figure 3-11. Block Diagram of Timer 2 Unit

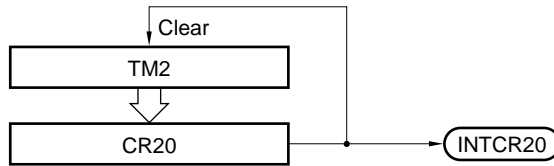

(5) Timer 4 unit

Timer 4 unit is a general-purpose 16-bit timer unit.

This unit consists of a timer 4 (TM4), a capture/compare register (CR40), and a capture register (CR41).

The value of the timer is captured to CR40/CR41 when the INTP2 signal is input. This timer can be used to decode a remote controller signal.

Figure 3-12. Block Diagram of Timer 4 Unit

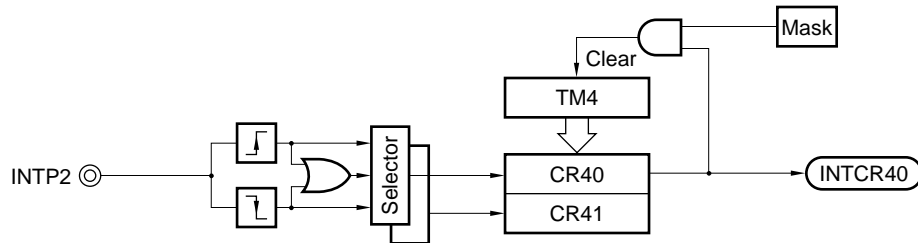

(6) Timer 5 unit

Timer 5 unit is a general-purpose 16-bit timer unit.

This unit consists of a timer 5 (TM5) and a compare register (CR50).

The timer is cleared by the TM5-CR50 coincidence signal, and at the same time, an interrupt request is generated.

Figure 3-13. Block Diagram of Timer 5 Unit

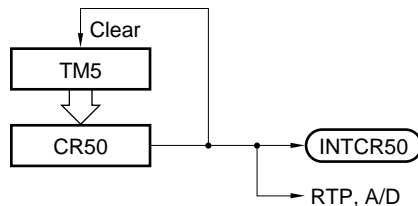

(7) Up/down counter unit

The up/down counter unit is a counter that realizes a linear time counter.

This unit consists of an up/down counter (UDC) and a compare register (UDCC).

The up/down counter counts up the rising edges of PBCTL and counts down the falling edges of PBCTL. When the value of the up/down counter coincides with the value of the compare register, or when the counter underflows, an interrupt request is generated.

Figure 3-14. Block Diagram of Up/Down Counter Unit

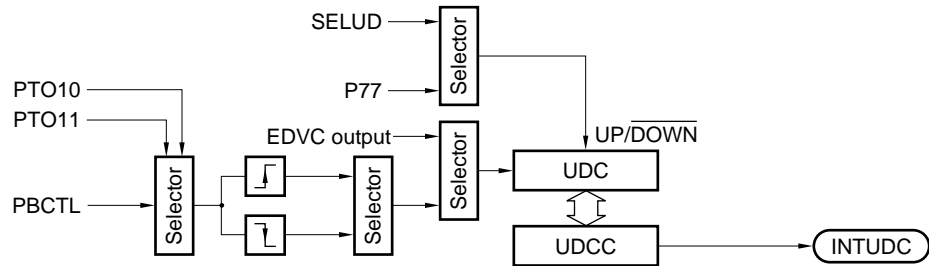

(8) PWM output unit

The PWM output unit has three 16-bit accuracy output lines (PWM0, PWM1, and PWM5) and 8-bit accuracy output lines (PWM2 to PWM4). The carrier frequency of all the output lines is 62.5 kHz ($f_{CLK} = 8 \text{ MHz}$).

PWM0 and PWM1 can be used to control the drum motor and capstan motor.

Figure 3-15. Block Diagram of 16-Bit PWM Output Unit

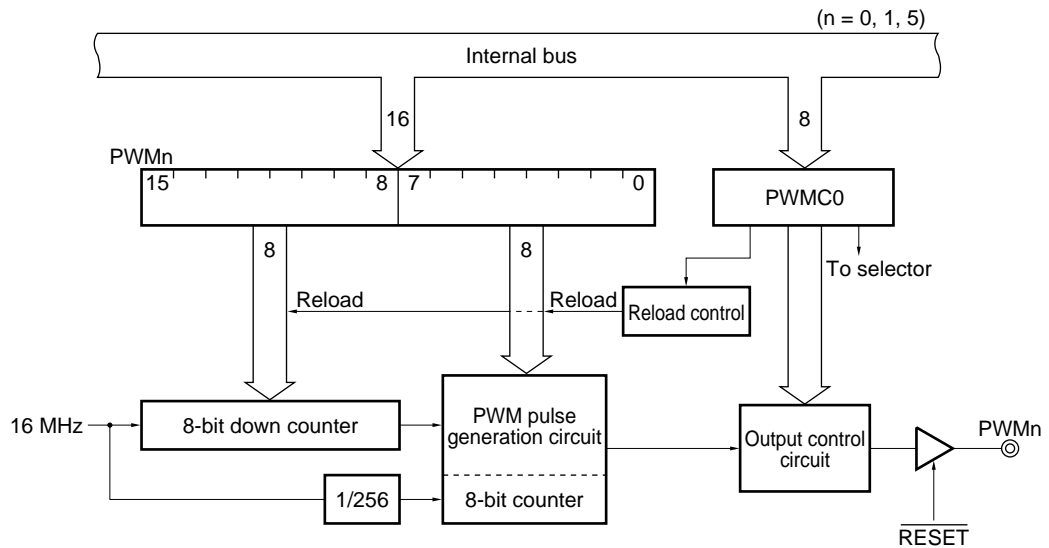
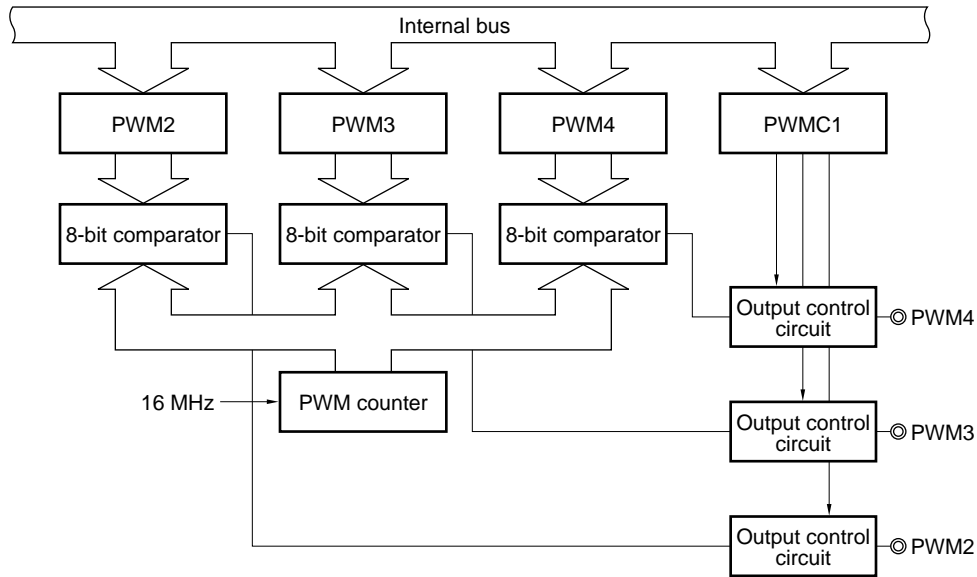

Figure 3-16. Block Diagram of 8-Bit PWM Output Unit



3.7 Serial Interface

The μPD784916B is provided with the serial interfaces shown in Table 3-7.

Data can be automatically transmitted or received through these serial interfaces, when the macro service is used.

Table 3-7. Types of Serial Interfaces

Name	Function
Serial interface channel 1	<ul style="list-style-type: none"> • Clocked serial interface (3-wire) • Bit length: 8 bits • Clock rate: External clock/31.25 kHz/62.5 kHz/125 kHz/250 kHz/500 kHz/1 MHz (f_{CLK} = 8 MHz) • MSB first/LSB first selectable
Serial interface channel 2	<ul style="list-style-type: none"> • Clocked serial interface (3-wire) • Bit length: 8 bits • Clock rate: External clock/31.25 kHz/62.5 kHz/125 kHz/250 kHz/500 kHz/1 MHz (f_{CLK} = 8 MHz) • MSB first/LSB first selectable • BUSY/STRB control function

Figure 3-17. Block Diagram of Serial Interface Channel n (n = 1 or 2)

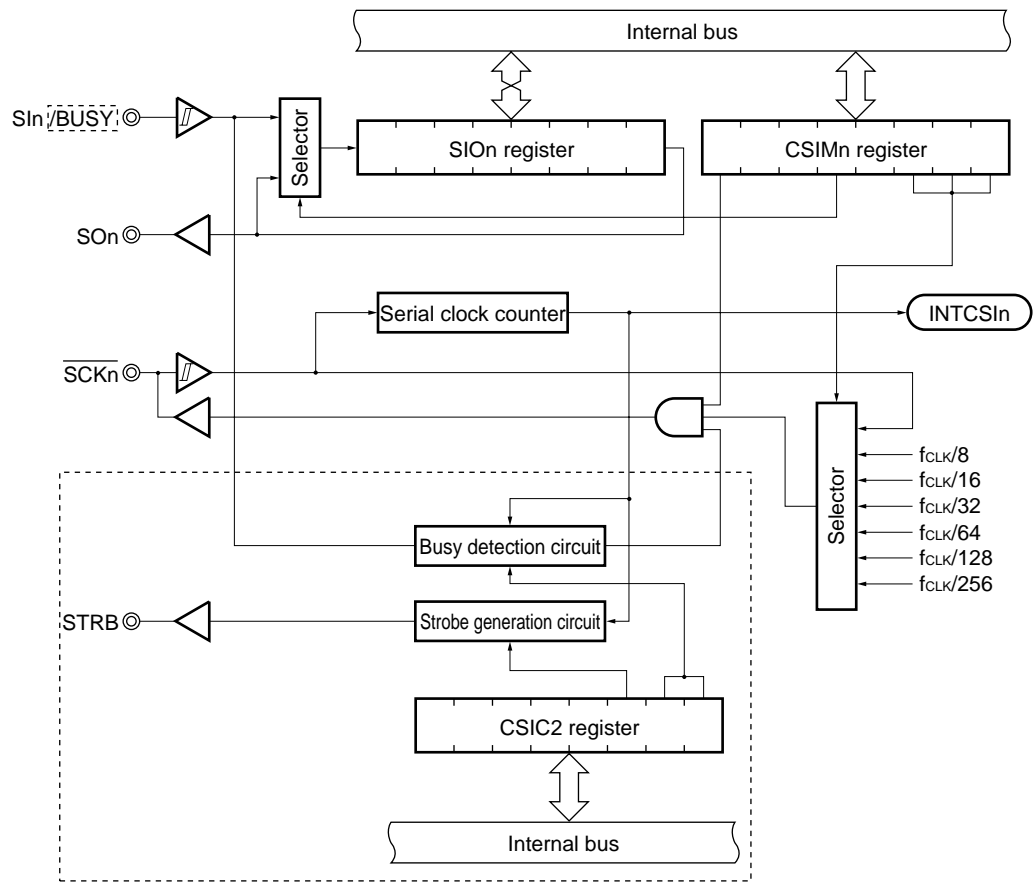

Remark The circuits enclosed in the broken line are provided for serial interface channel 2 only.

3.8 A/D Converter

The μ PD784916B has an analog-to-digital (A/D) converter with 12 multiplexed analog inputs (ANI0 to ANI11).

This A/D converter is of successive approximation type, and the conversion result is held by an 8-bit A/D conversion result register (ADCR) (conversion time: 10 μ s at $f_{CLK} = 8$ MHz).

A/D conversion can be started in the following two modes:

- Hardware start: Conversion is started by a hardware trigger^{Note}.
- Software start : Conversion is started by setting the A/D conversion mode register (ADM).

After conversion has been started, the A/D converter operates in the following modes:

- Scan mode : Sequentially selects more than one analog input to obtain data to be converted from all the pins.
- Select mode: Use only one pin for analog input to obtain successive data.

When the conversion result is transferred to ADCR, interrupt request INTAD is generated. By processing this interrupt with the macro service, the conversion result can be successively transferred to memory.

A mode in which starting A/D conversion of the next pin is kept pending until the value of ADCR is read is also available. When this mode is used, reading the conversion result by mistake when timing is shifted because an interrupt is disabled can be prevented.

Note A hardware trigger can be one of the following coincidence signals, one of which is selected by the trigger source select register 1 (TRGS1):

- TM0-CR01 coincidence signal
- TM0-CR02 coincidence signal
- TM1-CR13 coincidence signal
- TM5-CR50 coincidence signal

Figure 3-18. Block Diagram of A/D Converter

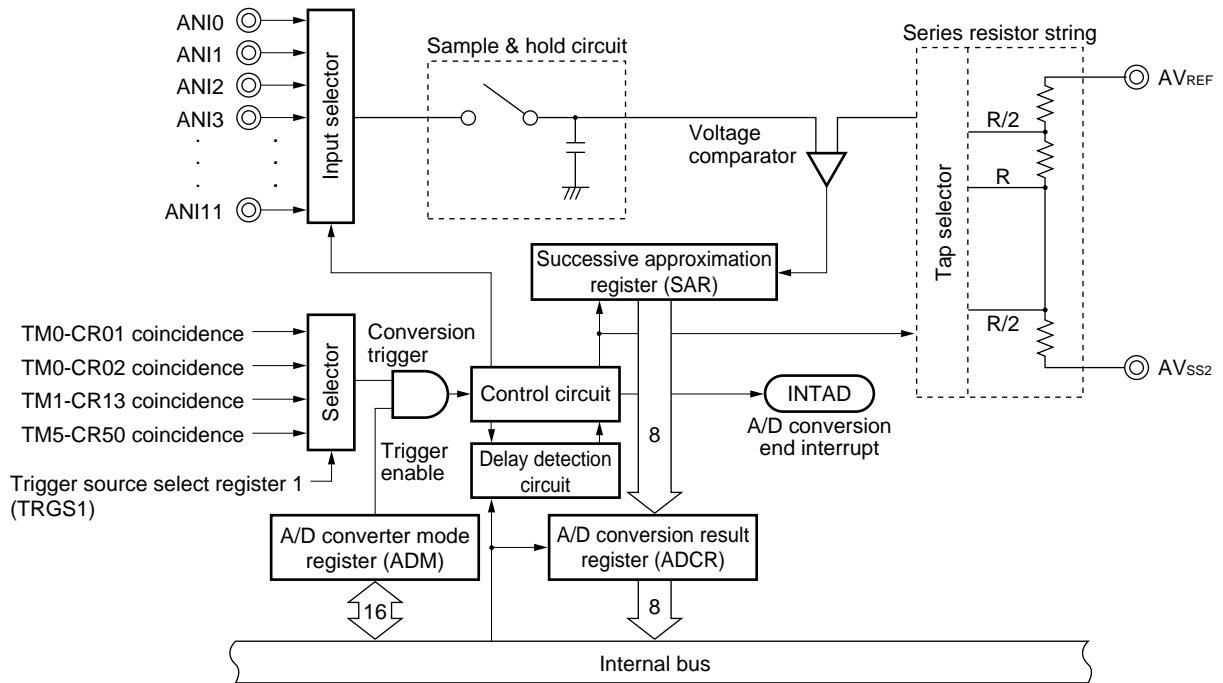

3.9 VCR Analog Circuits

The μPD784916B is provided with the following VCR analog circuits:

- CTL amplifier
- RECCTL driver (rewritable)
- DPG comparator
- DFG amplifier
- DPGF separation circuit (ternary separation circuit)
- CFG amplifier
- Reel FG comparator (2 channels)
- CSYNC comparator

(1) CTL amplifier/RECCTL driver

The CTL amplifier is used to amplify the playback control (PBCTL) signal that is reproduced from the CTL signal recorded on a VCR tape.

The gain of the CTL amplifier is set by the gain control register (CTLM). Thirty-two types of gains can be set in increments of about 1.78 dB.

The μPD784915 is also provided with a gain control signal generation circuit that monitors the status of the amplifier output to perform optimum gain control by program. The gain control signal generation circuit generates a CTL detection flag that identifies the amplitude status of the CTL amplifier output. By using this CTL detection flag, the gain of the CTL amplifier can be optimized.

The RECCTL driver writes a control signal onto a VCR tape.

This driver operates in two modes: REC mode that is used for recording, and rewrite mode used to rewrite the VISS signal. The output status of the RECCTL± pin is changed by hardware, by using the timer output from the super timer unit as a trigger.

Figure 3-19. Block Diagram of CTL Amplifier and RECCTL Driver

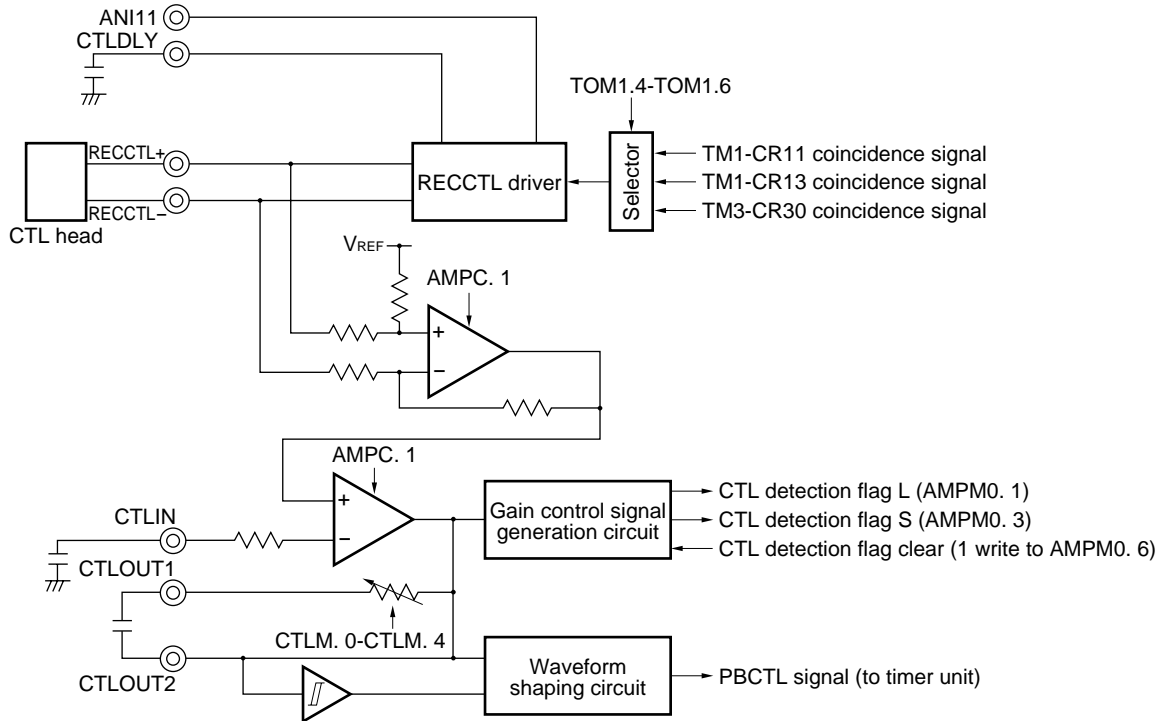

(2) DPG comparator, DFG amplifier, and DPFG separation circuit

The DPG comparator converts the drum PG (DPG) signal that indicates the phase information of the drum motor into a logic signal.

The DFG amplifier amplifies the drum FG (DFG) signal that indicates the speed information of the drum motor. The DPFG separation circuit (ternary separation circuit) separates a drum PFG (DPFG) signal having speed and phase information into a DFG and DPG signals.

Figure 3-20. Block Diagram of DPG Comparator, DFG Amplifier, and DPFG Separation Circuit

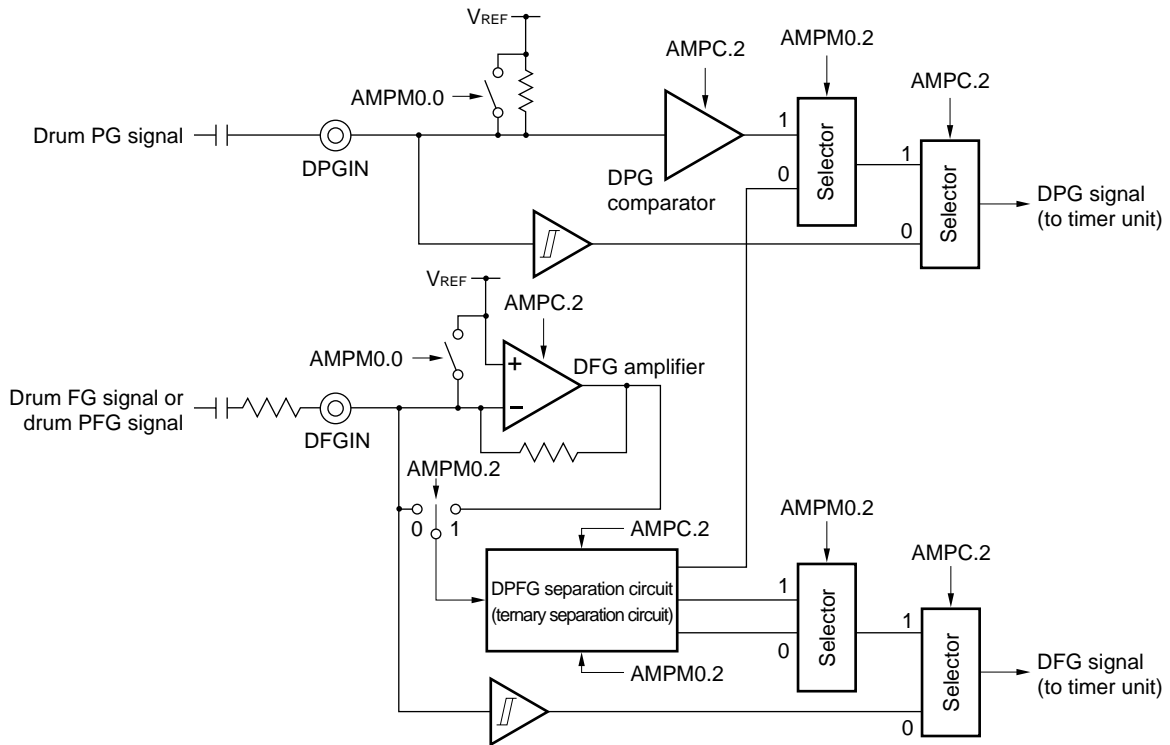

(3) CFG amplifier

The CFG amplifier amplifies the capstan FG (CFG) signal that indicates the speed information of the capstan motor. This amplifier consists of an operational amplifier and a comparator. The gain of the operational amplifier is set by using an external resistor.

When the gain of the operational amplifier is set to 50 dB, the output duty accuracy of the CFG signal can be improved to $50.0 \pm 0.3\%$.

Figure 3-21. Block Diagram of CFG Amplifier

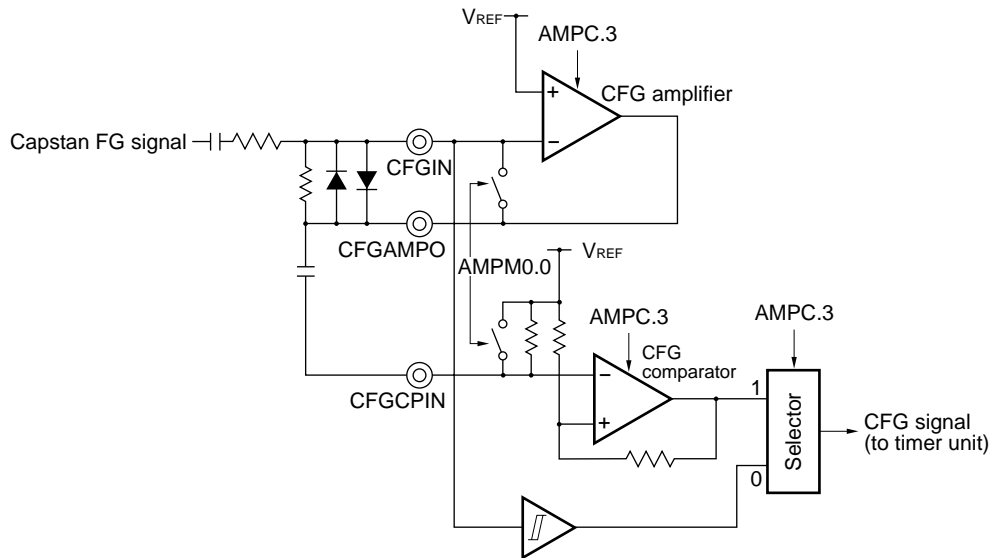

(4) Reel FG comparators

The reel FG comparator converts a reel FG signal that indicates the speed information of the reel motor into a logic signal. Two comparators, one for take-up and the other for supply, are provided.

Figure 3-22. Block Diagram of Reel FG Comparators

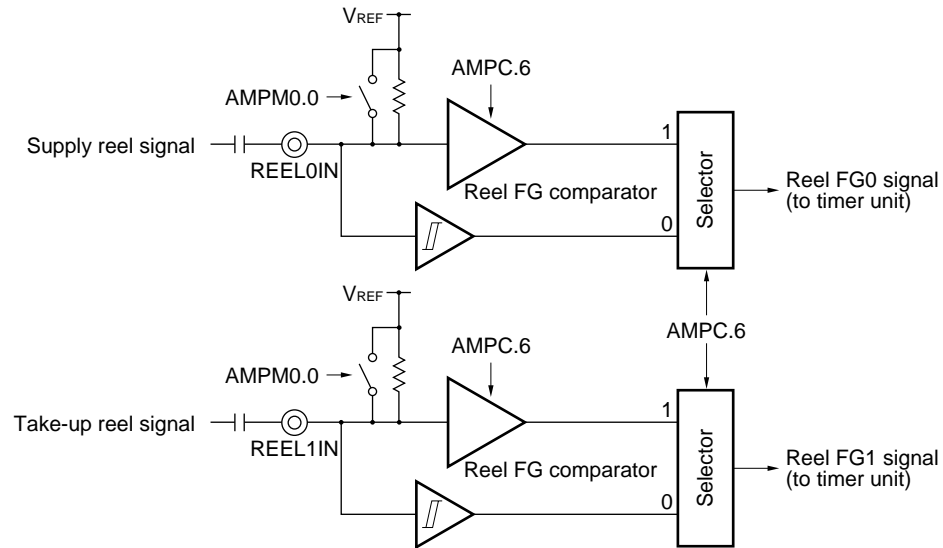

(5) CSYNC comparator

The CSYNC comparator converts the COMPSYNC signal into a logic signal.

Figure 3-23. Block Diagram of COMPSYNC Comparator

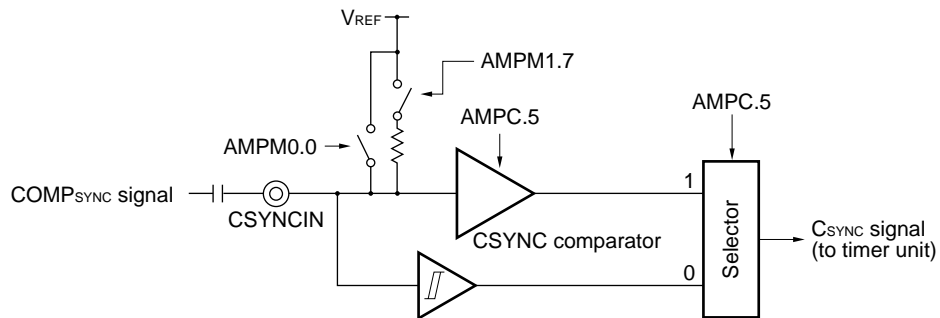

(6) Reference amplifier

The reference amplifier generates a reference voltage (V_{REF}) to be supplied to the internal amplifiers and comparators of the μPD784916B.

Figure 3-24. Block Diagram of Reference Amplifier

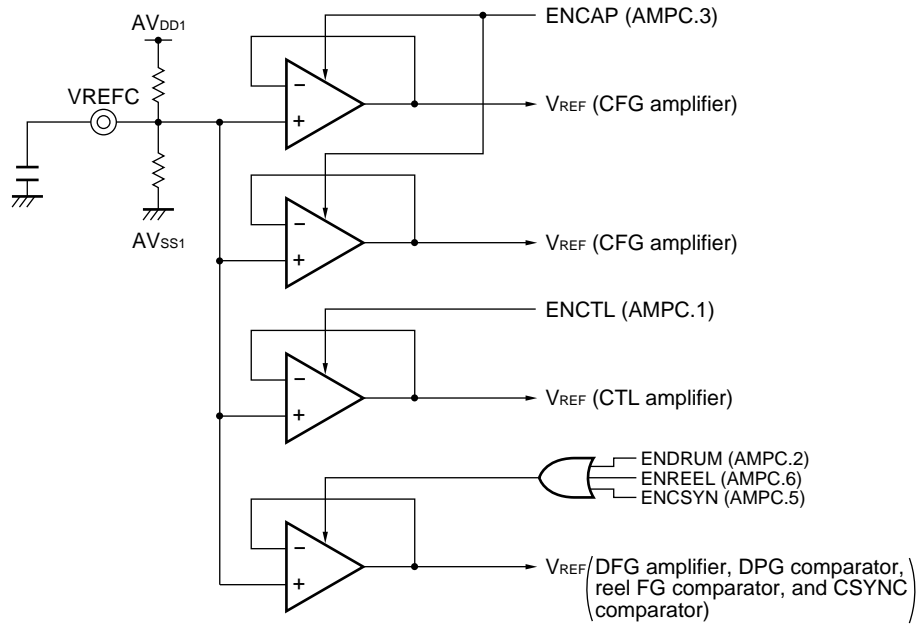

Remark Multiple reference amplifiers are provided to assure the accuracy of the amplifiers and comparators.

3.10 Watch Function

The μPD784916B has a watch function that counts the overflow signals of the watch timer by hardware. As the clock, the subsystem clock (32.768 kHz) is used.

Because this watch function is independent from the CPU, it can be used even while the CPU is in the standby mode (STOP mode) or is reset. In addition, this function can be used at a low voltage of $V_{DD} = 2.7\text{ V (MIN.)}$.

Therefore, by using only the watch function with the CPU set in the standby mode or reset, a watch operation can be performed at a low voltage and low current dissipation.

In addition, the watch function can also be used while the CPU is in the normal operation mode, because a dedicated counter is provided.

The watch function can be used to count up to about 17 years of data.

The hardware watch counters (HW0 and HW1) are shared with external input counters. These counters execute counting at the falling edge of input to the P65 pin, and can be used to count the H_{SYNC} signals.

Figure 3-25. Block Diagram of Watch Counter

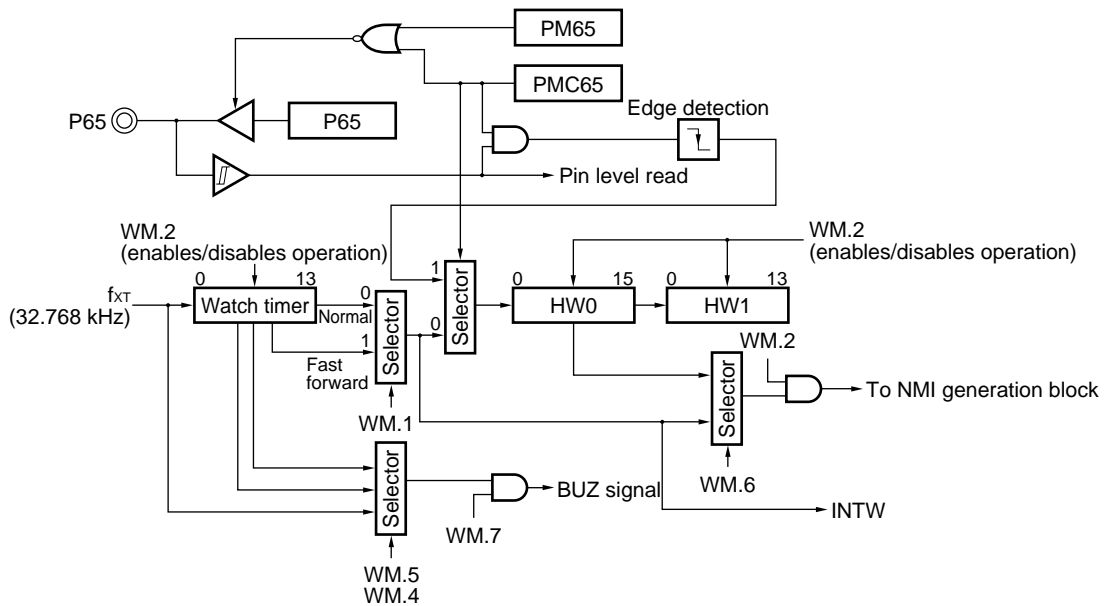

3.11 Clock Output Function

The μPD784916A can output a square wave (with a duty factor of 50%) to the P60/CLO pin as the operating clock for the peripheral devices or other microcontrollers. To enable or disable the clock output, and to set the frequency of the clock, the clock output mode register (CLOM) is used.

When setting the frequency, the division ratio can be set to f_{CLK}/n (where $n = 2, 4, 8, \text{ or } 16$) ($f_{CLK} = f_{osc}/2$: f_{osc} is the oscillation frequency of the oscillator).

Figure 3-26 shows the configuration of the clock output circuit.

The clock output (CLO) pin is shared with P60.

Figure 3-26. Block Diagram of Clock Output Circuit

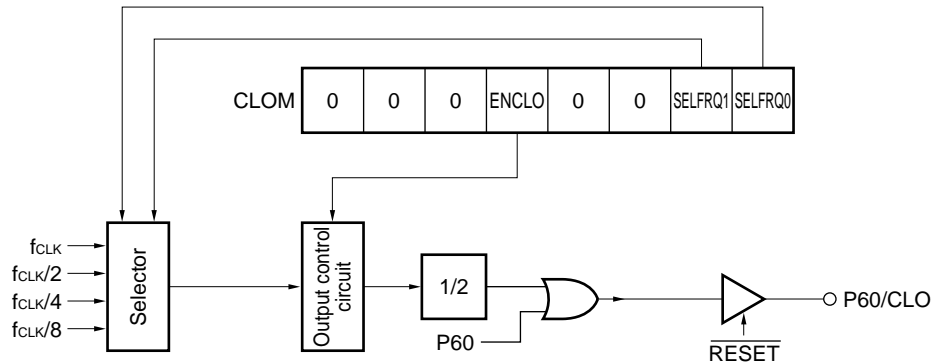

Remark f_{CLK} : internal system clock

Caution Do not use the clock output function in the STOP mode. Clear ENCL0 (CLOM.4) to 0 in the STOP mode.

Figure 3-27 Application Example of Clock Output Function

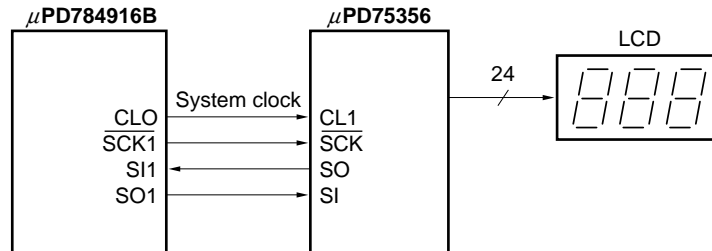

4. INTERNAL/EXTERNAL CONTROL FUNCTION

4.1 Interrupt Function

The μPD784916B has as many as 30 interrupt sources, including internal and external sources. For 26 sources, a high-speed interrupt processing mode such as context switching or macro service can be specified by software.

Table 4-1 lists the interrupt sources.

Table 4-1. Interrupt Sources

Interrupt Request Type	Priority	Interrupt Request Source		Interrupt Control Register Name	Macro Service	Context Switching	Macro Service Control Word Address	Vector Table Address
		Name	Trigger					
Reset	-	RESET	RESET pin input	-	No	No	-	0000H
Non-maskable	-	NMI	NMI pin input edge	-			-	0002H
Maskable	0	INTP0	INTP0 pin input edge	PIC0	Yes	Yes	FE06H	0006H
	1	INTCPT3	EDVC output signal (CPT3 capture)	CPTIC3			FE08H	0008H
	2	INTCPT2	DFGIN pin input edge (CPT2 capture)	CPTIC2			FE0AH	000AH
	3	INTCR12	PBCTL signal input edge/EDVC output signal (CR12 capture)	CRIC12			FE0CH	000CH
	4	INTCR00	TM0-CR00 coincidence signal	CRIC00			FE0EH	000EH
	5	INTCLR1	CSYNCIN pin input edge	CLRIC1			FE10H	0010H
	6	INTCR10	TM1-CR10 coincidence signal	CRIC10			FE12H	0012H
	7	INTCR01	TM0-CR01 coincidence signal	CRIC01			FE14H	0014H
	8	INTCR02	TM0-CR02 coincidence signal	CRIC02			FE16H	0016H
	9	INTCR11	TM1-CR11 coincidence signal	CRIC11			FE18H	0018H
	10	INTCPT1	Pin input edge/EC output signal (CPT1 capture)	CPTIC1			FE1AH	001AH
	11	INTCR20	TM2-CR20 coincidence signal	CRIC20			FE1CH	001CH
	12	INTTB	Time base from FRC	TBIC			FE20H	0020H
	13	INTAD	A/D converter conversion end	ADIC			FE22H	0022H
	14	INTP2	INTP2 pin input edge	PIC2			FE24H	0024H
		INTCR40	TM4-CR40 coincidence signal	CRIC40				
	15	INTUDC	UDC-UDCC coincidence/UDC underflow	UDCIC			FE26H	0026H
	16	INTCR30	TM3-CR30 coincidence signal	CRIC30			FE28H	0028H
	17	INTCR50	TM5-CR50 coincidence signal	CRIC50			FE2AH	002AH
	18	INTCR13	TM1-CR13 coincidence signal	CRIC13			FE2CH	002CH
	19	INTCSI1	End of serial transfer (channel 1)	CSIIC1			FE2EH	002EH
	20	INTW	Overflow of watch timer	WIC			FE30H	0030H
	21	INTP1	INTP1 pin input edge	PIC1			FE34H	0034H
22	INTP3	INTP3 pin input edge	PIC3	FE36H	0036H			
23	INTCSI2	End of serial transfer (channel 2)	CSIIC2	FE3AH	003AH			
Operand error	-	-	Illegal operand of MOV STBC, #byte or LOCATION instruction	-	No	No	-	003CH
Software	-	-	Execution of BRK instruction	-			-	003EH
	-	-	Execution of BRKCS instruction	-			Yes	-

Figure 4-1. Differences in Operation Depending on Interrupt Processing Mode

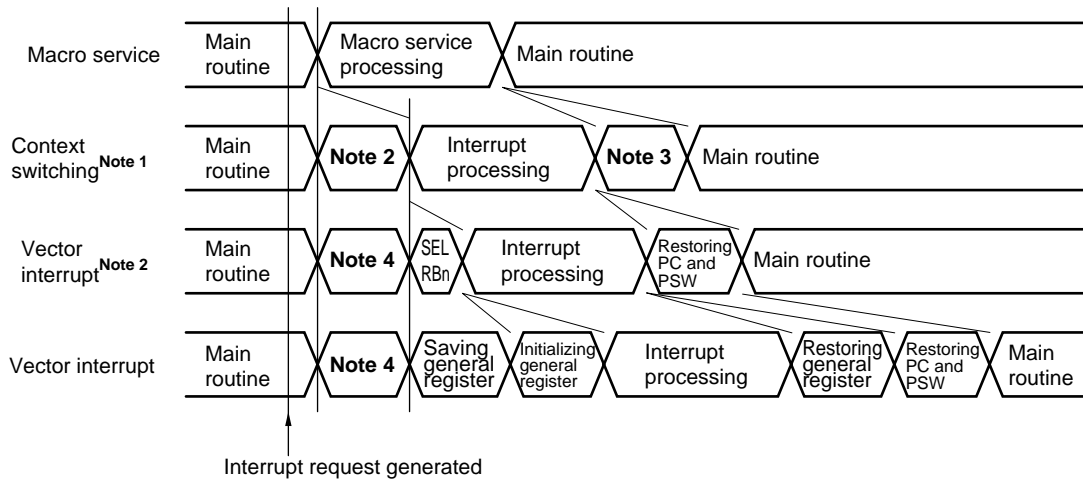

- Notes**
1. When the register bank switching function is used and when initial values are set in advance to the registers
 2. Selecting a register bank and saving PC and PSW by context switching
 3. Restoring register bank, PC, and PSW by context switching
 4. Saves PC and PSW to stack and loads vector address to PC

4.1.1 Vector interrupt

When an interrupt request is acknowledged, an interrupt processing program is executed according to the data stored in the vector table area (the first address of the interrupt processing program created by the user).

Four levels of priorities can be specified by software for the vector interrupts of the μPD784916B.

4.1.2 Context switching

When an interrupt request is generated or when the BRKCS instruction is executed, a specific register bank is selected by hardware, and execution branches to a vector address set in advance in the register bank. At the same time, the current contents of the program counter (PC) and program status word (PSW) are saved to the registers in the register bank. Because the contents of PC and PSW are not saved to the stack area, execution can be branched to an interrupt processing routine more quickly than the vector interrupt.

Figure 4-2. Context Switching Operation When Interrupt Request Is Generated

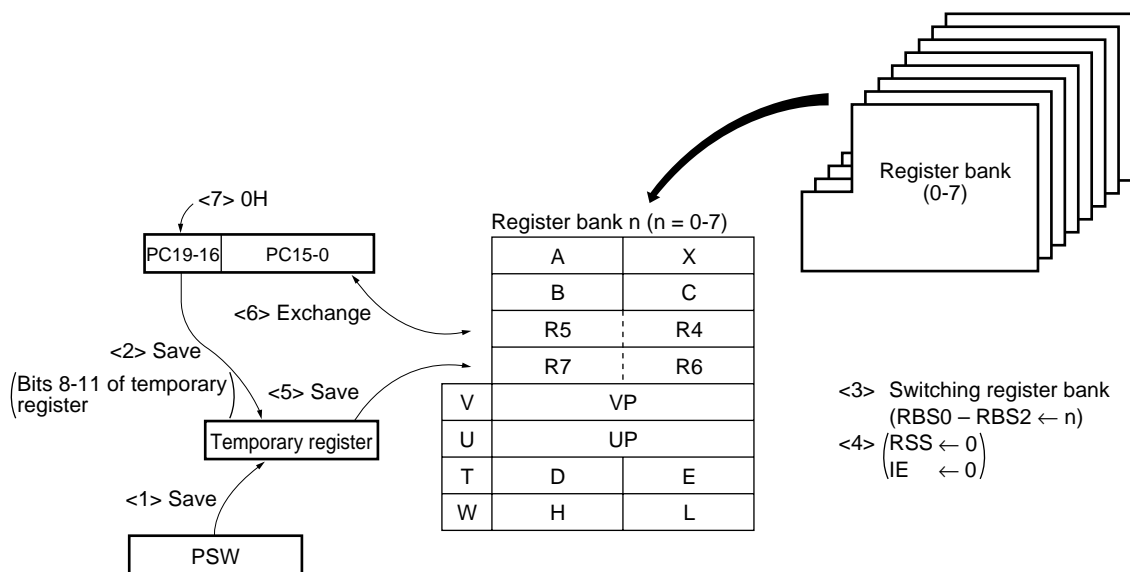

4.1.3 Macro service

The macro service is a function to transfer data between the memory and a special function register (SFR) without intervention by the CPU. A macro service controller accesses the memory and SFR and directly transfers the data. Because the status of the CPU is not saved or restored, data can be transferred more quickly than context switching. The processing that can be executed with the macro service is described below.

Figure 4-3. Macro Service

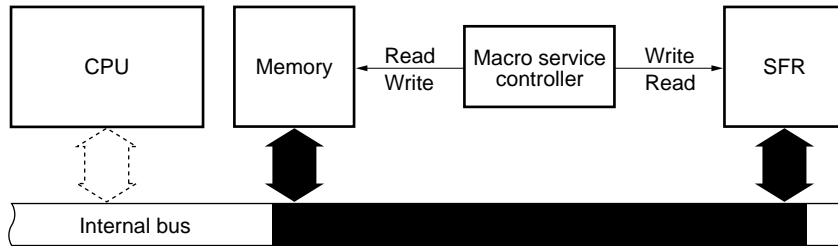

(1) Counter mode

In this mode, the value of the macro service counter (MSC) is decremented when an interrupt request occurs. This mode can be used to execute the division operation of an interrupt or count the number of times an interrupt has occurred.

When the value of the macro service counter has been decremented to 0, a vector interrupt occurs.



(2) Compound data transfer mode

When an interrupt request occurs, data are simultaneously transferred from an 8-bit SFR to memory, a 16-bit SFR to memory (word), memory (byte) to an 8-bit SFR, and memory (word) to a 16-bit SFR (3 points MAX. for each transfer).

This mode can also be used to exchange data, instead of transferring data.

This mode can be used for automatic transfer/reception by the serial interface or automatic updating of data/timing by the serial output port.

When the value of the macro service counter reaches to 0, a vector interrupt request occurs.

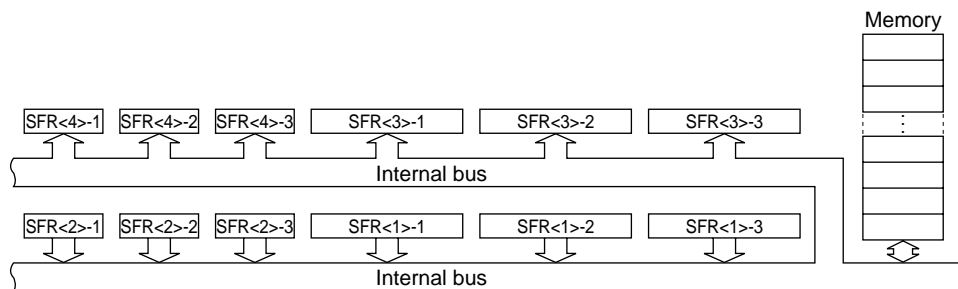

(3) Macro service type A

When an interrupt request occurs, data is transferred from an 8-/16-bit SFR to memory (byte/word) or from memory (byte/word) to an 8-/16-bit SFR.

Data is transferred the number of times set in advance by the macro service counter.

This mode can be used to store the result of A/D conversion or for automatic transfer (or reception) by the serial interface.

Because transfer data is stored at an address FE00H to FEFFH, if only a small quantity of data is to be transferred, the data can be transferred at high speeds.

When the value of the macro service counter is decremented to 0, a vector interrupt request occurs.

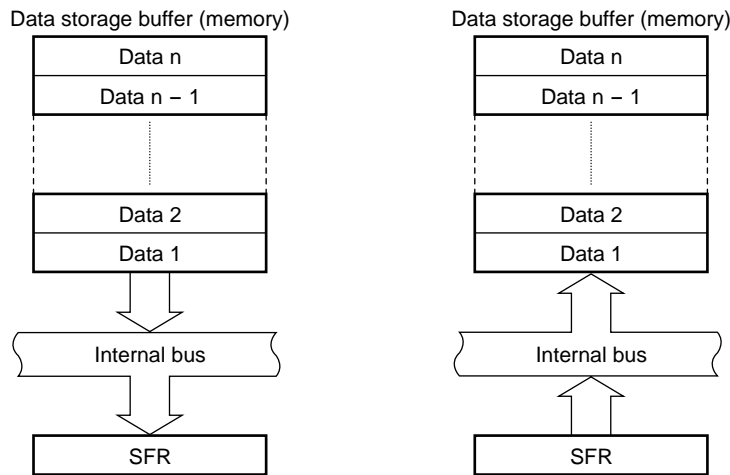

(4) Data pattern identification mode (VISS detection mode)

This mode of macro service is for detection of the VISS signal and is used in combination with a pulse width detection circuit.

When an interrupt request occurs, the content of bit 7 of an SFR (usually, TMC3) specified by SFR pointer 1 is shifted into the buffer area. At the same time, the data in the buffer area is compared with the data in the compare area. If the two data coincide, an interrupt request is generated. When the value of the macro service counter is decremented to 0, a vector interrupt request occurs.

It can be specified by option that the value of an SFR (usually, CPT30) specified by SFR pointer 2 be multiplied by a coefficient and the result of this multiplication be stored to an SFR (usually, CR30) specified by SFR pointer 3 (this operation is to automatically update an identification threshold value when the tape speed fluctuates).

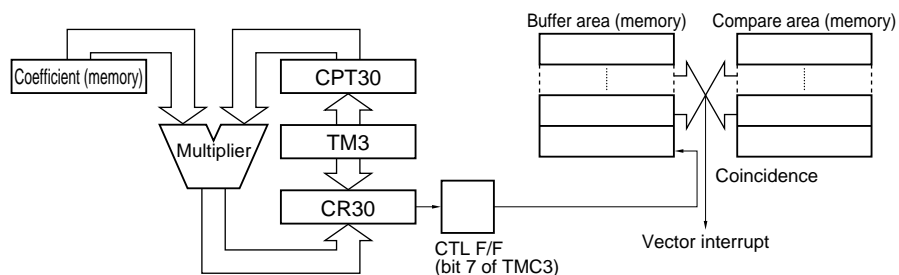

4.1.4 Application example of macro service

(1) Automatic transfer/reception of serial interface

Automatic transfer/reception of 3-byte data by serial interface channel 1

Setting of macro service register: compound data transfer mode (exchange mode)

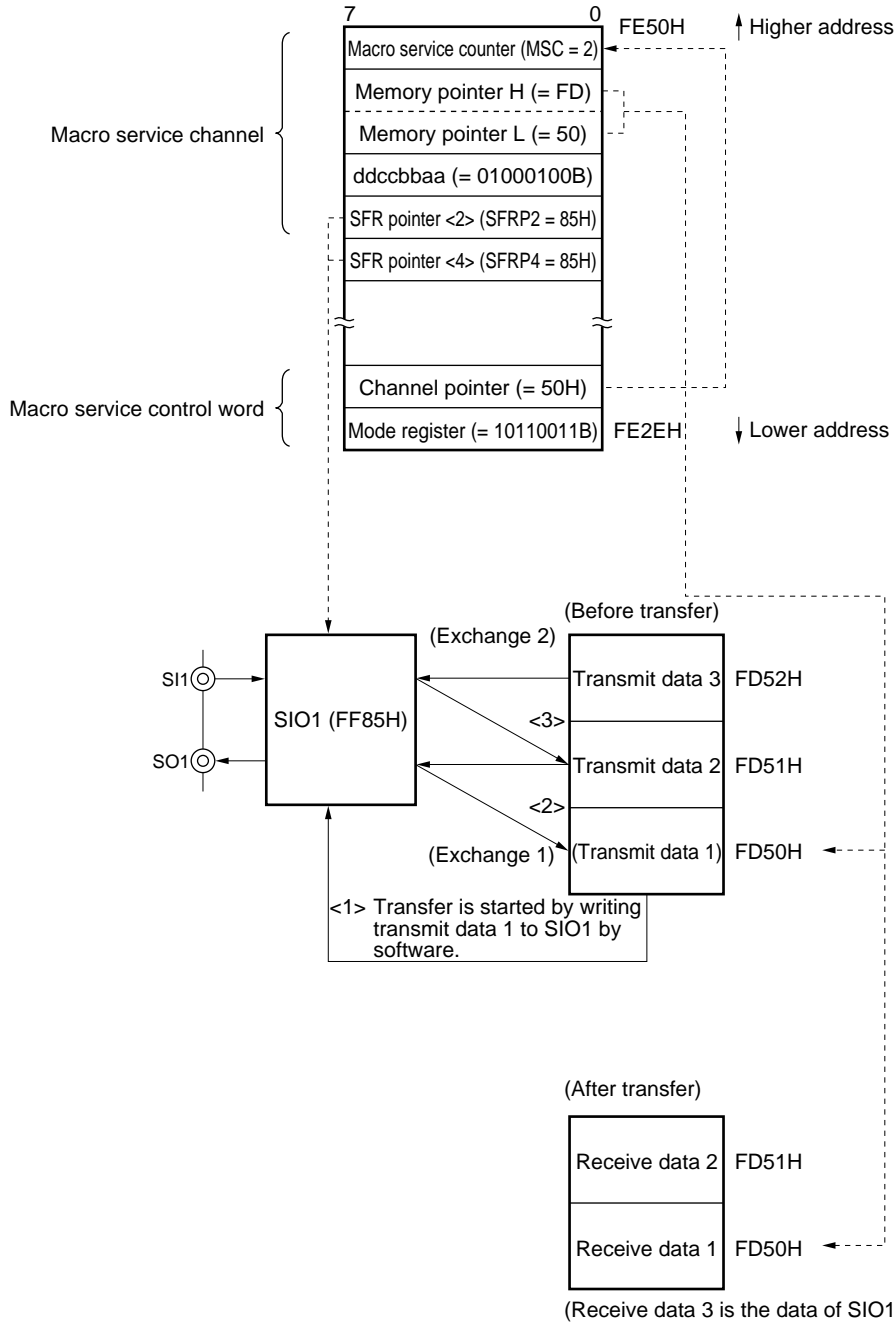

(2) Reception operation of serial interface

Transfer of receive data by serial interface channel 1 (16 bytes)

Setting of macro service mode register: macro service type A (1-byte transfer from SFR to memory)

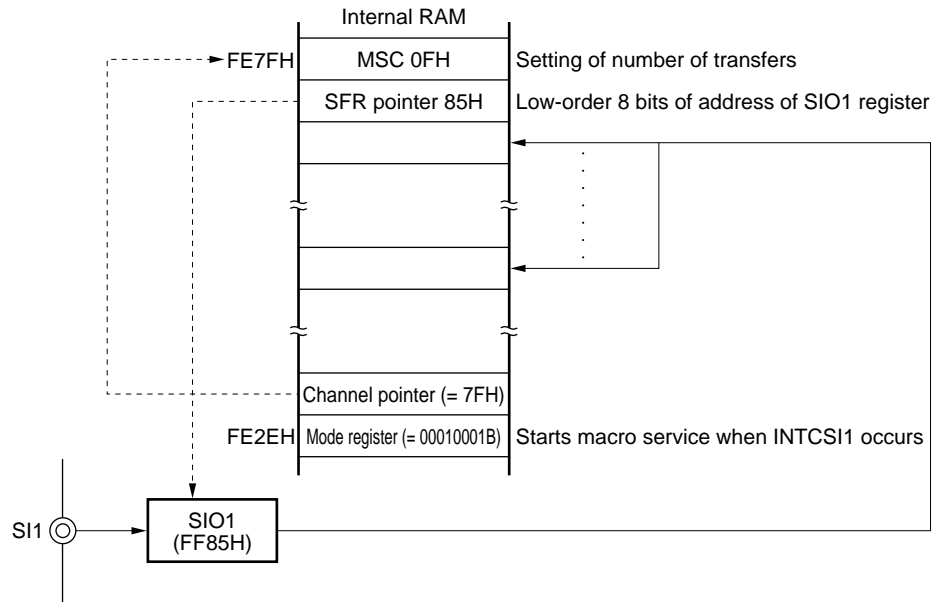

(3) VISS detection operation

Setting of macro service mode register: data pattern identification mode (with multiplication, 8-byte comparison)

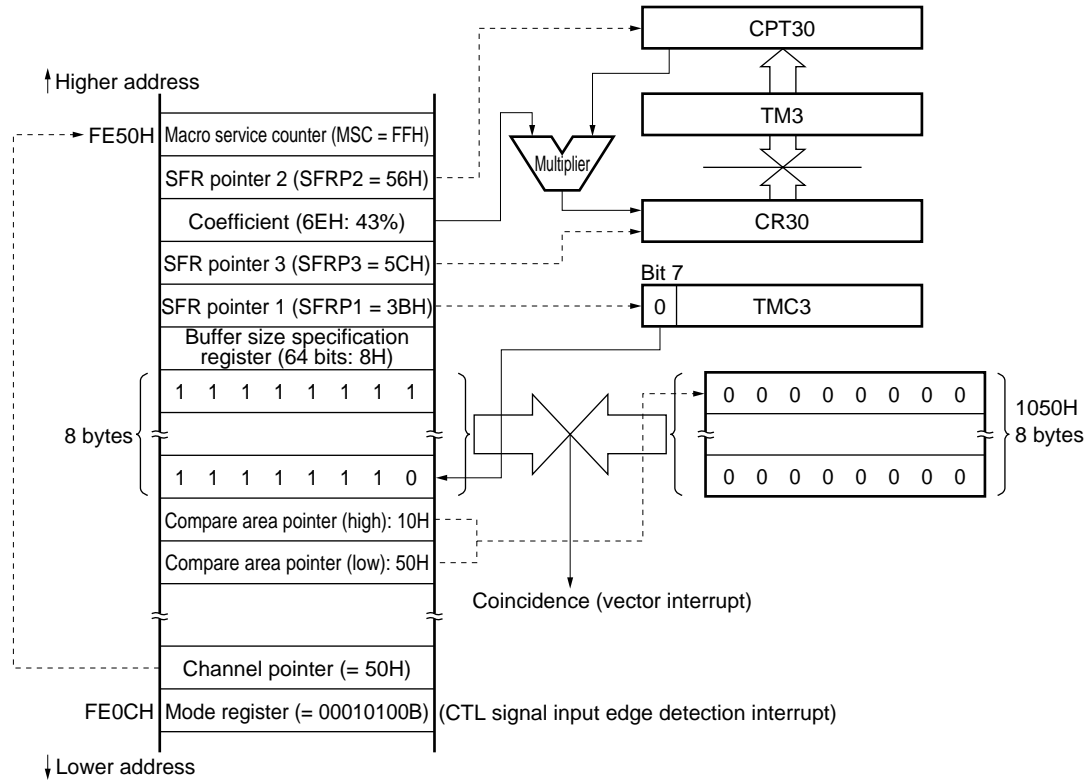

4.2 Standby Function

The standby function serves to reduce the power dissipation of the chip and is used in the following modes:

Mode	Function
HALT mode	Stops operating clock of CPU. Reduces average power dissipation when used in combination with normal mode for intermittent operation
STOP mode	Stops oscillator. Stops all internal operations of chip to minimize current dissipation to leakage current only
Low power dissipation mode	Stops main system clock with subsystem clock used as system clock. CPU can operate with subsystem clock to reduce power dissipation
Low power dissipation HALT mode	Standby function in low power dissipation mode. Stops operating clock of CPU. Reduces power dissipation of overall system

These modes are programmable.

The macro service can be started in the HALT mode.

Figure 4-4. Status Transition of Standby Mode

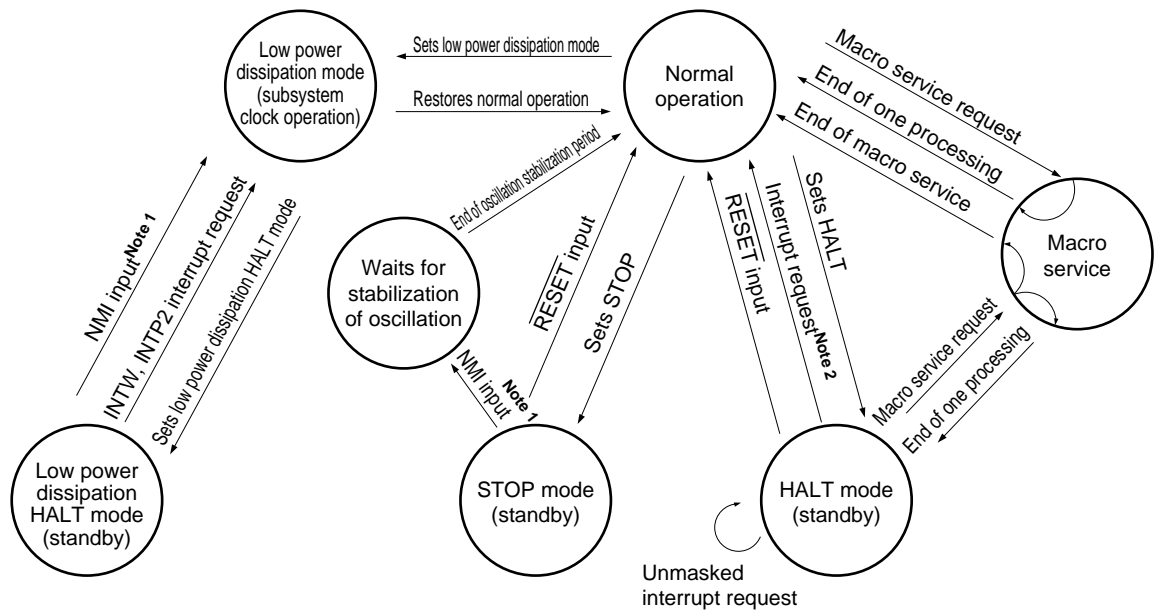

Notes 1. NMI input means starting NMI by NMI pin input, watch interrupt, or key interrupt input.

2. Unmasked interrupt request

Figure 4-5. Relations among NMI, Watch Interrupt, and Key Interrupt When STOP Mode Is Released

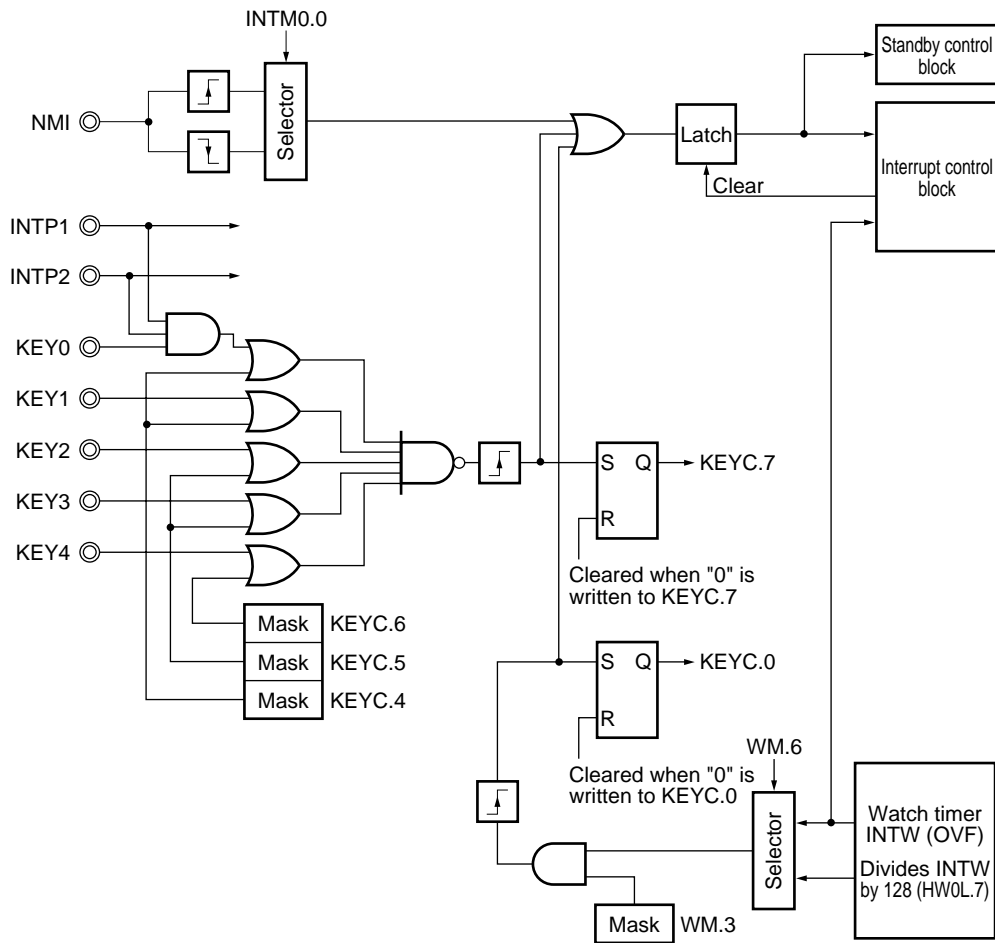

4.3 Clock Generator Circuit

The clock generator circuit generates and controls the internal system clock (CLK) to be supplied to the CPU and peripheral circuits. Figure 4-6 shows the configuration of this circuit.

Figure 4-6. Block Diagram of Clock Generator Circuit

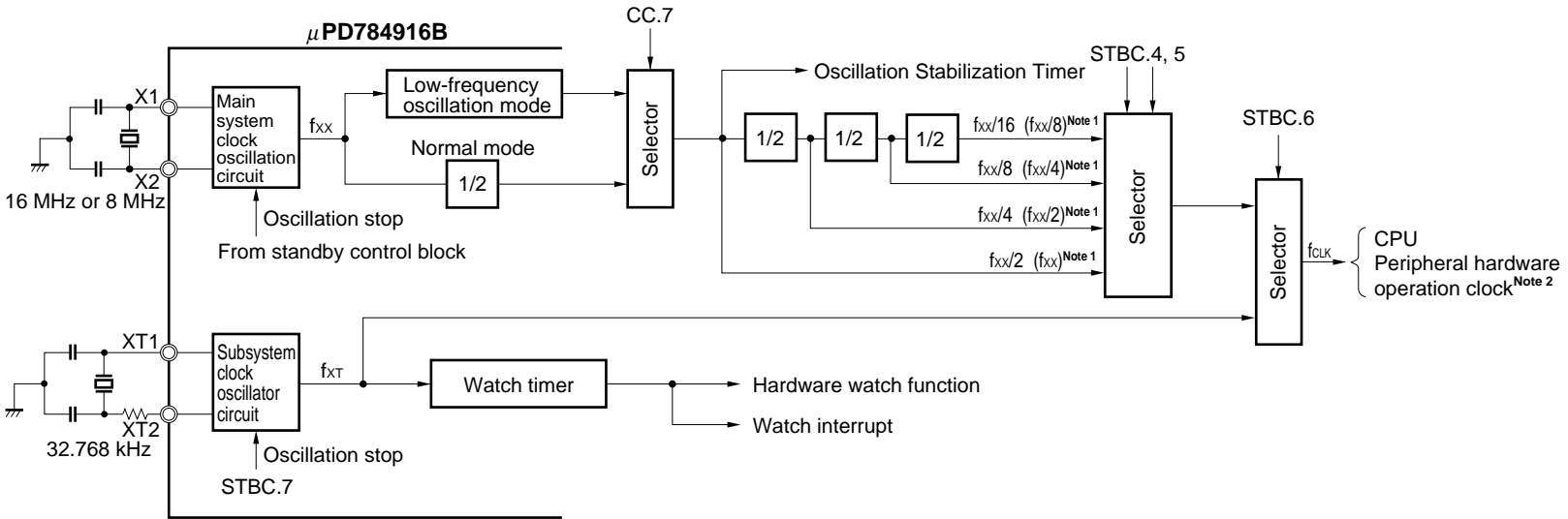

- Notes**
- Oscillation frequency, values in parentheses indicate the low frequency oscillation mode.
 - The peripheral hardware units that can operate with the subsystem clock have some restrictions. For details, refer to **14.6 Low Power Dissipation Mode** in **μPD784915 Subseries User's Manual**.

4.4 Reset Function

When a low-level signal is input to the $\overline{\text{RESET}}$ pin, the system is reset, and each hardware unit is initialized (reset status). During the reset period, oscillation of the system clock is unconditionally stopped, so that the current dissipation of the overall system can be reduced.

When the $\overline{\text{RESET}}$ pin goes high, the reset status is cleared. After the count time of the oscillation stabilization timer (32.8 ms at 16 MHz or 65.6 ms at 8 MHz) has elapsed, the contents of the reset vector table are set to the program counter (PC), and execution branches to the address set to the PC, and the program is executed starting from the branch destination address. Therefore, execution can be reset and started from any address.

Figure 4-7. Oscillation of Main System Clock during Reset Period

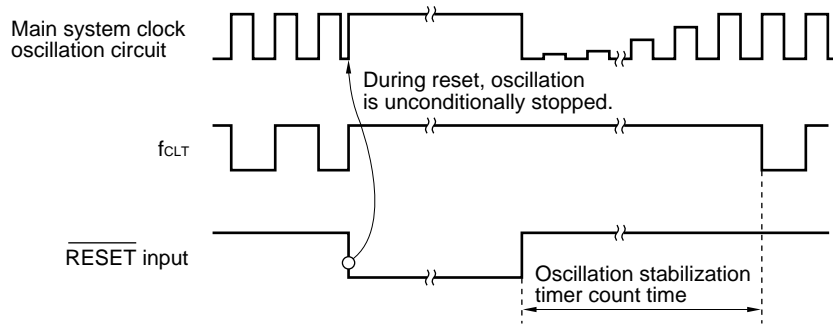

The $\overline{\text{RESET}}$ pin is provided with an analog delay noise elimination circuit to prevent malfunctioning due to noise.

Figure 4-8. Accepting Reset Signal

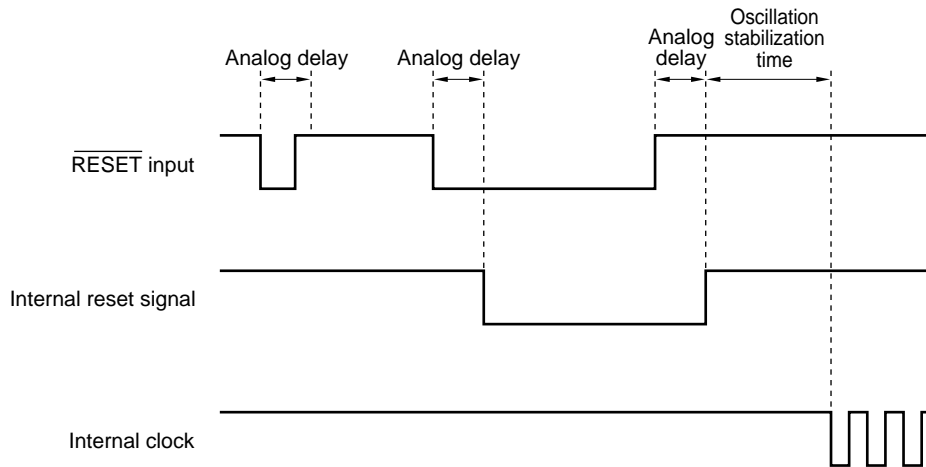

5. INSTRUCTION SETS

(1) 8-bit instructions ((): combination realized by describing A as r)

MOV, XCH, ADD, ADDC, SUB, SUBC, AND, OR, XOR, CMP, MULU, DIVUW, INC, DEC, ROR, ROL, RORC, ROLC, SHR, SHL, ROR4, ROL4, DBNZ, PUSH, POP, MOV M, XCH M, CMP M E, CMP M NE, CMP M NC, CMP M C, MOV B K, XCH B K, CMP B KE, CMP B KNE, CMP B KNC, CMP B KC, CHKL, CHKLA

2nd Operand 1st Operand	# byte	A	r r'	saddr saddr'	sfr	!addr16 !!addr24	mem [saddrp] [%saddrg]	r3 PSWL PSWH	[WHL+]	[WHL-]	n	None ^{Note 2}
A	(MOV) ADD ^{Note 1}	(MOV) (XCH) (ADD) ^{Note 1}	MOV XCH (ADD) ^{Note 1}	(MOV) ^{Note 6} (XCH) ^{Note 6} (ADD) ^{Notes 1,6}	MOV (XCH) (ADD) ^{Note 1}	(MOV) (XCH) ADD ^{Note 1}	MOV XCH ADD ^{Note 1}	MOV	(MOV) (XCH) (ADD) ^{Note 1}	(MOV) (XCH) (ADD) ^{Note 1}		
r	MOV ADD ^{Note 1}	(MOV) (XCH) (ADD) ^{Note 1}	MOV XCH ADD ^{Note 1}	MOV XCH ADD ^{Note 1}	MOV XCH ADD ^{Note 1}	MOV XCH					ROR ^{Note 3}	MULU DIVUW INC DEC
saddr	MOV ADD ^{Note 1}	(MOV) ^{Note 6} (ADD) ^{Note 1}	MOV ADD ^{Note 1}	MOV XCH ADD ^{Note 1}								INC DEC DBNZ
sfr	MOV ADD ^{Note 1}	MOV (ADD) ^{Note 1}	MOV ADD ^{Note 1}									PUSH POP CHKL CHKLA
!addr16 !!addr24	MOV	(MOV) ADD ^{Note 1}	MOV									
mem [saddrp] [%saddrg]		MOV ADD ^{Note 1}										
mem3												ROR4 ROL4
r3 PSWL PSWH	MOV	MOV										
B, C												DBNZ
STBC, WDM	MOV											
[TDE+]		(MOV) (ADD) ^{Note 1} MOV M ^{Note 4}							MOV B K ^{Note 5}			
[TDE-]		(MOV) (ADD) ^{Note 1} MOV M ^{Note 4}								MOV B K ^{Note 5}		

- Notes**
- ADDC, SUB, SUBC, AND, OR, XOR, and CMP are the same as ADD.
 - Either the second operand is not used, or the second operation is not an operand address.
 - ROL, RORC, ROLC, SHR, and SHL are the same as ROR.
 - XCH M, CMP M E, CMP M NE, CMP M NC, and CMP M C are the same as MOV M.
 - XCH B K, CMP B KE, CMP B KNE, CMP B KNC, and CMP B KC are the same as MOV B K.
 - If saddr2 instead of saddr is used in this combination, the code length of some instructions is short.

(2) 16-bit instructions ((): combination realized by describing AX as rp)

MOVW, XCHW, ADDW, SUBW, CMPW, MULW, MULW, DIVUX, INCW, DECW, SHRW, SHLW, PUSH, POP, ADDWG, SUBWG, PUSHU, POPU, MOVTBLW, MACW, MACSW, SACW

2nd Operand 1st Operand	# word	AX	rp rp'	saddrp saddrp'	sfrp	!addr16 !!addr24	mem [saddrp] [%saddrg]	[WHL+]	byte	n	None ^{Note 2}
AX	(MOVW) ADDW ^{Note 1}	(MOVW) (XCHW) (ADDW) ^{Note 1}	(MOVW) (XCHW) (ADDW) ^{Note 1}	(MOVW) ^{Note 3} (XCHW) ^{Note 3} (ADDW) ^{Notes 1, 3}	MOVW (XCHW) (ADDW) ^{Note 1}	(MOVW) XCHW	MOVW XCHW	(MOVW) (XCHW)			
rp	MOVW ADDW ^{Note 1}	(MOVW) (XCHW) (ADDW) ^{Note 1}	MOVW XCHW ADDW ^{Note 1}	MOVW XCHW ADDW ^{Note 1}	MOVW XCHW ADDW ^{Note 1}	MOVW				SHRW SHLW	MULW ^{Note 4} INCW DECW
saddrp	MOVW ADDW ^{Note 1}	(MOVW) ^{Note 3} (ADDW) ^{Note 1}	MOVW ADDW ^{Note 1}	MOVW XCHW ADDW ^{Note 1}							INCW DECW
sfrp	MOVW ADDW ^{Note 1}	MOVW (ADDW) ^{Note 1}	MOVW ADDW ^{Note 1}								PUSH POP
!addr16 !!addr24	MOVW	(MOVW)	MOVW						MOVTBLW		
mem [saddrp] [%saddrg]		MOVW									
PSW											PUSH POP
SP	ADDWG SUBWG										
post											PUSH POP PUSHU POPU
[TDE+]		(MOVW)						SACW			
byte											MACW MACSW

- Notes**
1. SUBW and CMPW are the same as ADDW.
 2. Either the second operand is not used, or the second operation is not an operand address.
 3. If saddr2 instead of saddr is used in this combination, the code length of some instructions is short.
 4. MULW and DIVUX are the same as MULW.

(3) 24-bit instructions ((): combination realized by describing WHL as rg)

MOVG, ADDG, SUBG, INCG, DECG, PUSH, POP

2nd Operand 1st Operand	# imm24	WHL	rg rg'	saddrg	!!addr24	mem1	[%saddrg]	SP	None ^{Note}
WHL	(MOVG) (ADDG) (SUBG)	(MOVG) (ADDG) (SUBG)	(MOVG) (ADDG) (SUBG)	(MOVG) ADDG SUBG	(MOVG)	MOVG	MOVG	MOVG	
rg	MOVG ADDG SUBG	(MOVG) (ADDG) (SUBG)	MOVG ADDG SUBG	MOVG	MOVG				INCG DECG PUSH POP
saddrg		(MOVG)	MOVG						
!!addr24		(MOVG)	MOVG						
mem1		MOVG							
[%saddrg]		MOVG							
SP	MOVG	MOVG							INCG DECG

Note Either the second operand is not used, or the second operation is not an operand address.

(4) Bit manipulation instructions

MOV1, AND1, OR1, XOR1, SET1, CLR1, NOT1, BT, BF, BTCLR, BFSET

2nd Operand 1st Operand	CY	saddr.bit sfr.bit A.bit X.bit PSWL.bit PSWH.bit mem2.bit !addr16.bit !addr24.bit	/saddr.bit /sfr.bit /A.bit /X.bit /PSWL.bit /PSWH.bit /mem2.bit /!addr16.bit /!addr24.bit	None ^{Note}
CY		MOV1 AND1 OR1 XOR1	AND1 OR1	NOT1 SET1 CLR1
saddr.bit sfr.bit A.bit X.bit PSWL.bit PSWH.bit mem2.bit !addr16.bit !addr24.bit	MOV1			NOT1 SET1 CLR1 BF BT BTCLR BFSET

Note Either the second operand is not used, or the second operation is not an operand address.

(5) Call/return and branch instructions

CALL, CALLF, CALLT, BRK, RET, RETI, RETB, RETCS, RETCSB, BRKCS, BR, BNZ, BNE, BZ, BE, BNC, BNL, BC, BL, BNV, BPO, BV, BPE, BP, BN, BLT, BGE, BLE, BGT, BNH, BH, BF, BT, BTCLR, BFSET, DBNZ

Operand of instruction address	\$addr20	!addr20	!addr16	!!addr20	rp	rg	[rp]	[rg]	!addr11	[addr5]	RBn	None
Basic instruction	BC ^{Note} BR	CALL BR	CALL BR RETCS RETCSB	CALL BR	CALL BR	CALL BR	CALL BR	CALL BR	CALLF	CALLT	BRKCS	BRK RET RETI RETB
Compound instruction	BF BT BTCLR BFSET DBNZ											

Note BNZ, BNE, BZ, BE, BNC, BNL, BL, BNV, BPO, BV, BPE, BP, BN, BLT, BGE, BLE, BGT, BNH, and BH are the same as BC.

(6) Other instructions

ADJBA, ADJBS, CVTBW, LOCATION, SEL, NOT, EI, DI, SWRS

6. ELECTRICAL CHARACTERISTICS

Absolute Maximum Ratings (T_A = 25°C)

Parameter	Symbol	Condition	Ratings	Unit
Supply voltage	V _{DD}	V _{DD} - AV _{DD1} ≤ 0.5 V	-0.5 to +7.0	V
	AV _{DD1}	V _{DD} - AV _{DD2} ≤ 0.5 V	-0.5 to +7.0	V
	AV _{DD2}	AV _{DD1} - AV _{DD2} ≤ 0.5 V	-0.5 to +7.0	V
	AV _{SS1}		-0.5 to +0.5	V
	AV _{SS2}		-0.5 to +0.5	V
Input voltage	V _I		-0.5 to V _{DD} + 0.5	V
Analog input voltage (ANI0 to ANI11)	V _{IAN}	V _{DD} ≥ AV _{DD2}	-0.5 to AV _{DD2} + 0.5	V
		V _{DD} < AV _{DD2}	-0.5 to V _{DD} + 0.5	V
Output voltage	V _O		-0.5 to V _{DD} + 0.5	V
Low-level output current	I _{OL}	Pin 1	15	mA
		Total of all pins	100	mA
High-level output current	I _{OH}	Pin 1	-10	mA
		Total of all pins	-50	mA
Operating ambient temperature	T _A		-10 to +70	°C
Storage temperature	T _{stg}		-65 to +150	°C

Caution If the rated value of even one of the above parameters is exceeded even momentarily, the quality of the product may be degraded. Absolute maximum ratings therefore specify the values exceeding which the product may be physically damaged. Never exceed these values when using the product.

Operating Conditions

Clock Frequency	Operating Temperature (T _A)	Operating Conditions	Supply Voltage (V _{DD})
4 MHz ≤ f _{xx} ≤ 16 MHz	-10 to +70°C	All functions	+4.5 to +5.5 V
		CPU function only	+4.0 to +5.5 V
32 kHz ≤ f _{XT} ≤ 35 kHz		Subclock operation (CPU, watch, and port functions only)	+2.7 to +5.5 V

Oscillator Characteristics (main clock) ($T_A = -10$ to $+70^\circ\text{C}$, $V_{DD} = AV_{DD} = 4.0$ to 5.5 V, $V_{SS} = AV_{SS} = 0$ V)

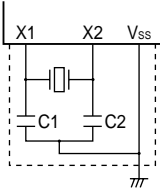
Oscillator	Recommended Circuit	Parameter	MIN.	MAX.	Unit
Crystal oscillator		Oscillation frequency (f_{xx})	4	16	MHz

Oscillator Characteristics (subclock) ($T_A = -10$ to $+70^\circ\text{C}$, $V_{DD} = AV_{DD} = 2.7$ to 5.5 V, $V_{SS} = AV_{SS} = 0$ V)

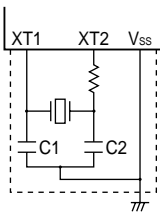
Oscillator	Recommended Circuit	Parameter	MIN.	MAX.	Unit
Crystal oscillator		Oscillation frequency (f_{XT})	32	35	kHz

Caution When using the main system clock and subsystem clock oscillation circuits, wire the portion enclosed by the broken line in the above figures as follows to avoid the adverse influence of wiring capacitance:

- Keep the wiring length as short as possible.
- Do not cross the wiring with the other signal lines. Do not route the wiring in the neighborhood of a signal line through which a high alternating current flows.
- Always keep the ground point of the capacitor of the oscillator circuit to the same potential as V_{SS} . Do not ground the capacitor to a ground pattern to which a high current flows.
- Do not extract signals from the oscillation circuit.

Exercise particular care in using the subsystem clock oscillation circuit because the amplification factor of this circuit is kept low to reduce the power dissipation.

DC Characteristics (T_A = -10 to +70°C, V_{DD} = AV_{DD} = 4.5 to 5.5 V, V_{SS} = AV_{SS} = 0 V)

Parameter	Symbol	Conditions	MIN.	TYP.	MAX.	Unit	
Low-level input voltage	V _{IL1}	Pins other than those listed in Note 1 below	0		0.3 V _{DD}	V	
	V _{IL2}	Pins listed in Note 1 below	0		0.2 V _{DD}	V	
	V _{IL3}	X1, X2	0		0.4	V	
High-level input voltage	V _{IH1}	Pins other than those listed in Note 1 below	0.7 V _{DD}		V _{DD}	V	
	V _{IH2}	Pins listed in Note 1 below	0.8 V _{DD}		V _{DD}	V	
	V _{IH3}	X1, X2	V _{DD} - 0.5		V _{DD}	V	
Low-level output voltage	V _{OL1}	I _{OL} = 5.0 mA (pins in Note 2)			0.6	V	
	V _{OL2}	I _{OL} = 2.0 mA			0.45	V	
	V _{OL3}	I _{OL} = 100 μA			0.25	V	
High-level output voltage	V _{OH1}	I _{OH} = -1.0 mA	V _{DD} - 1.0			V	
	V _{OH2}	I _{OH} = -100 μA	V _{DD} - 0.4			V	
Input leakage current	I _{LI}	0 ≤ V _I ≤ V _{DD}			±10	μA	
Output leakage current	I _{LO}	0 ≤ V _O ≤ V _{DD}			±10	μA	
V _{DD} supply current	I _{DD1}	Operation mode	f _{XX} = 16 MHz f _{XX} = 8 MHz (low-frequency oscillation mode) Internally, 8-MHz main system clock operation		30	50	mA
			f _{XT} = 32.768 kHz Subclock operation (CPU, watch, port) V _{DD} = 2.7 V		50	80	μA
	I _{DD2}	HALT mode	f _{XX} = 16 MHz f _{XX} = 8 MHz (low-frequency oscillation mode) Internally, 8-MHz main clock operation		10	25	mA
			f _{XT} = 32.768 MHz Subclock operation (CPU, watch, port) V _{DD} = 2.7 V		25	50	μA
Data hold voltage	V _{DDDR}	STOP mode	2.5			V	
Data hold current ^{Note 3}	I _{DDDR}	STOP mode Subclock oscillates V _{DDDR} = 5.0 V		18	50	μA	
		STOP mode Subclock oscillates V _{DDDR} = 2.7 V		2.5	10	μA	
		STOP mode Subclock stops V _{DDDR} = 2.5 V		0.2	7.0	μA	
Pull-up resistor	R _L	V _I = 0 V	25	55	110	kΩ	

- Notes**
1. $\overline{\text{RESET}}$, IC, NMI, INTP0-INTP2, P61/ $\overline{\text{SCK1}}$ /BUZ, P63/SI1, $\overline{\text{SCK2}}$, SI2/BUSY, P65/HWIN, P91/KEY0-P95/KEY4
 2. P46, P47
 3. In the STOP mode in which the subclock oscillation is stopped, disconnect the feedback resistor, and connect the XT1 pin to V_{DD}.

AC Characteristics

CPU and peripheral circuit operation clock (T_A = -10 to +70°C, V_{DD} = AV_{DD} = 4.5 to 5.5 V, V_{SS} = AV_{SS} = 0 V)

Parameter	Symbol	Condition	TYP.	Unit
CPU operation clock cycle time	t _{CLK}	f _{xx} = 16 MHz V _{DD} = AV _{DD} = 4.0 to 5.5 V CPU Function only	125	ns
		f _{xx} = 16 MHz		
		f _{xx} = 8 MHz low-frequency oscillation mode (Bit 7 of CC = 1)		
Peripheral operation clock cycle time	t _{CLK1}	f _{xx} = 16 MHz	125	ns
		f _{xx} = 8MHz low-frequency oscillation mode (Bit 7 of CC = 1)		

Serial interface

(1) SIO_n: n = 1 or 2 (T_A = -10 to +70°C, V_{DD} = AV_{DD} = 4.5 to 5.5 V, V_{SS} = AV_{SS} = 0 V)

Parameter	Symbol	Condition	MIN.	MAX.	Unit	
Serial clock cycle time	t _{CYSK}	Input External clock	1.0		μs	
		Output	f _{CLK1} /8	1.0		μs
			f _{CLK1} /16	2.0		μs
			f _{CLK1} /32	4.0		μs
			f _{CLK1} /64	8.0		μs
			f _{CLK1} /128	16		μs
			f _{CLK1} /256	32		μs
Serial clock high- and low-level widths	t _{WSKH}	Input External clock	420		ns	
	t _{WSKL}	Output Internal clock	t _{CYSK} /2 - 50		ns	
SIn setup time (to $\overline{\text{SCKn}}$ ↑)	t _{SSSK}		100		ns	
SIn hold time (from $\overline{\text{SCKn}}$ ↑)	t _{HSSK}		400		ns	
SOn output delay time (to $\overline{\text{SCKn}}$ ↓)	t _{DSSK}		0	300	ns	

- Remarks**
1. f_{CLK1}: operating clock of peripheral circuit (8 MHz)
 2. n = 1 or 2

(2) SIO₂ only (T_A = -10 to +70°C, V_{DD} = AV_{DD} = 4.5 to 5.5 V, V_{SS} = AV_{SS} = 0 V)

Parameter	Symbol	Condition	MIN.	MAX.	Unit
$\overline{\text{SCK2}}(8) \uparrow \rightarrow \text{STRB} \uparrow$	t _{DSTRB}		t _{WSKH}	t _{CYSK}	
Strobe high-level width	t _{WSTRB}		t _{CYSK} - 30	t _{CYSK} + 30	ns
BUSY setup time (to BUSY detection timing)	t _{SBUSY}		100		ns
BUSY hold time (to BUSY detection timing)	t _{HBUSY}		100		ns
BUSY inactive $\rightarrow \overline{\text{SCK2}}(1) \downarrow$	t _{LBUSY}			t _{CYSK} + t _{WSKH}	

- Remarks**
1. The value in parentheses following $\overline{\text{SCK2}}$ indicates the number of $\overline{\text{SCK2}}$.
 2. BUSY is detected after the time (n+2) x t_{CYSK} (n = 0, 1, and so on) has elapsed relative to $\overline{\text{SCK2}}(8) \uparrow$.
 3. BUSY inactive $\rightarrow \overline{\text{SCK2}}(1) \downarrow$ is the value when data write to SIO₂ has been completed.

Other operations (T_A = -10 to +70°C, V_{DD} = AV_{DD} = 4.5 to 5.5 V, V_{SS} = AV_{SS} = 0 V)

Parameter		Symbol	Condition	MIN.	MAX.	Unit
Timer input signal low-level width		t _{WCTL}	When DFGIN, CFGIN, DPGIN, REEL0IN, or REEL1IN logic level is input	t _{CLK1}		ns
Timer input signal high-level width		t _{WCTH}	When DFGIN, CFGIN, DPGIN, REEL0IN, or REEL1IN logic level is input	t _{CLK1}		ns
Timer input signal valid edge input cycle		t _{PERIN}	When DFGIN, CFGIN, or DPGIN is input	2		μs
CSYNCIN low-level width		t _{WCR1L}	When digital noise elimination circuit is not used	8t _{CLK1}		ns
			When digital noise elimination circuit is used (Bit 4 of INTM2 = 0)	108t _{CLK1}		ns
			When digital noise elimination circuit is used (Bit 4 of INTM2 = 1)	180t _{CLK1}		ns
CSYNCIN high-level width		t _{WCR1H}	When digital noise elimination circuit is not used	8t _{CLK1}		ns
			When digital noise elimination circuit is used (Bit 4 of INTM2 = 0)	108t _{CLK1}		ns
			When digital noise elimination circuit is used (Bit 4 of INTM2 = 1)	180t _{CLK1}		ns
Digital noise elimination circuit	Eliminated pulse width	t _{WSEP}	Bit 4 of INTM2 = 0		104t _{CLK1}	ns
			Bit 4 of INTM2 = 1		176t _{CLK1}	ns
	Passed pulse width		Bit 4 of INTM2 = 0	108t _{CLK1}		ns
			Bit 4 of INTM2 = 1	180t _{CLK1}		ns
NMI low-level width		t _{WNIL}	V _{DD} = AV _{DD} = 2.7 to 5.5 V	10		μs
NMI high-level width		t _{WNIH}	V _{DD} = AV _{DD} = 2.7 to 5.5 V	10		μs
INTP0, INTP3 low-level widths		t _{WIPL0}		2t _{CLK1}		ns
INTP0, INTP3 high-level widths		t _{WIPH0}		2t _{CLK1}		ns
INTP1, KEY0 to KEY4 low-level widths		t _{WIPL1}	Mode other than STOP mode	2t _{CLK1}		ns
			In STOP mode, for releasing STOP mode	10		μs
INTP1, KEY0 to KEY4 high-level widths		t _{WIPH1}	Mode other than STOP mode	2t _{CLK1}		ns
			In STOP mode, for releasing STOP mode	10		μs
INTP2 low-level width		t _{WIPL2}	In normal mode, with main clock	Sampling = f _{CLK}	2t _{CLK1}	ns
				Sampling = f _{CLK} /128	32 ^{Note}	μs
			Normal mode, with subclock	Sampling = f _{CLK}	61	μs
				Sampling = f _{CLK} /128	7.9 ^{Note}	ms
			In STOP mode, for releasing STOP mode	10		μs
INTP2 high-level width		t _{WIPH2}	In normal mode, with main clock	Sampling = f _{CLK}	2t _{CLK1}	ns
				Sampling = f _{CLK} /128	32 ^{Note}	μs
			Normal mode, with subclock	Sampling = f _{CLK}	61	μs
				Sampling = f _{CLK} /128	7.9 ^{Note}	ms
			In STOP mode, for releasing STOP mode	10		μs
RESET low-level width		t _{WRSL}		10		μs

Note If a high or low level is successively input two times during the sampling period, a high or low level is detected.

Remark t_{CLK1}: operating clock cycle time of peripheral circuit (125 ns)

Clock output operation (T_A = -10 to +70°C, V_{DD} = AV_{DD} = 4.5 to 5.5 V, V_{SS} = AV_{SS} = 0 V)

Parameter	Symbol	Condition	MIN.	MAX.	Unit
CLO cycle time	t _{CYCL}		250	2000	ns
CLO low-level width	t _{CLL}	t _{CYCL} /2 ± 50	75	1050	ns
CLO high-level width	t _{CLH}	t _{CYCL} /2 ± 50	75	1050	ns
CLO rise time	t _{CLR}			50	ns
CLO fall time	t _{CLF}			50	ns

Data hold characteristics (T_A = -10 to +70°C, V_{DD} = AV_{DD} = 2.5 to 5.5 V, V_{SS} = AV_{SS} = 0 V)

Parameter	Symbol	Condition	MIN.	TYP.	MAX.	Unit
Low-level input voltage	V _{IL}	Special pins (pins in Note)	0		0.1 V _{DDDR}	V
High-level input voltage	V _{IH}		0.9 V _{DDDR}		V _{DDDR}	V

Note $\overline{\text{RESET}}$, IC, NMI, INTP0-INTP2, P61/ $\overline{\text{SCK1}}$ /BUZ, P63/SI1, $\overline{\text{SCK2}}$, SI2/BUSY, P65/HWIN, P91/KEY0-P95/KEY4

Watch function (T_A = -10 to +70°C, V_{DD} = AV_{DD} = 2.7 to 5.5 V, V_{SS} = AV_{SS} = 0 V)

Parameter	Symbol	Condition	MIN.	MAX.	Unit
Subclock oscillation hold voltage	V _{DDXT}		2.7		V
Hardware watch function operating voltage	V _{DDW}		2.7		V

Subclock oscillation stop detection flag (T_A = -10 to +70°C, V_{DD} = AV_{DD} = 4.5 to 5.5 V, V_{SS} = AV_{SS} = 0 V)

Parameter	Symbol	Condition	MIN.	MAX.	Unit
Oscillation stop detection width	t _{OSCF}		45		μs

A/D converter characteristics (T_A = -10 to +70°C, V_{DD} = AV_{DD} = AV_{REF} = 4.5 to 5.5 V, V_{SS} = AV_{SS} = 0 V)

Parameter	Symbol	Condition	MIN.	TYP.	MAX.	Unit
Resolution			8			bit
Total error		AV _{REF} = V _{DD}			2.0	%
Quantization error					±1/2	LSB
Conversion time	t _{CONV}	Bit 4 of ADM = 0	160t _{CLK1}			μs
		Bit 4 of ADM = 1	80t _{CLK1}			μs
Sampling time	t _{SAMP}	Bit 4 of ADM = 0	32t _{CLK1}			μs
		Bit 4 of ADM = 1	16t _{CLK1}			μs
Analog input voltage	V _{IAN}		0		AV _{REF}	V
Analog input impedance	Z _{AN}			1000		MΩ
AV _{REF} current	I _{AREF}			0.4	1.2	mA

VREF amplifier (T_A = 25°C, V_{DD} = AV_{DD} = 5 V, V_{SS} = AV_{SS} = 0 V)

Parameter	Symbol	Condition	MIN.	TYP.	MAX.	Unit
Reference voltage	V _{REF}		2.35	2.50	2.65	V
Charge current	I _{CHG}	Sets AMPM0.0 to 1 (pins in Note)	300			μA

Note RECCTL+, RECCTL-, CFGIN, CFGCPIN, DFGIN, DPGIN, CSYNCIN, REEL0IN, REEL1IN

CTL amplifier (T_A = 25°C, V_{DD} = AV_{DD} = 5 V, V_{SS} = AV_{SS} = 0 V)

Parameter	Symbol	Condition	MIN.	TYP.	MAX.	Unit
CTL+, - input resistance	R _{ICTL}		2	5	10	kΩ
Feedback resistance	R _{FCTL}		20	50	100	kΩ
Bias resistance	R _{BCTL}		20	50	100	kΩ
Minimum voltage gain	G _{CTLMIN}		17	20	22	dB
Maximum voltage gain	G _{CTLMAX}		71	75		dB
Gain selecting step	S _{GAIN}			1.77		dB
In-phase elimination ratio	CMR	DC, voltage gain: 20 dB		50		dB
High comparator set voltage of waveform shaping	V _{PBCTLHS}		V _{REF} + 0.47	V _{REF} + 0.50	V _{REF} + 0.53	V
High comparator reset voltage of waveform shaping	V _{PBCTLHR}		V _{REF} + 0.27	V _{REF} + 0.30	V _{REF} + 0.33	V
Low comparator set voltage of waveform shaping	V _{PBCTLLS}		V _{REF} - 0.53	V _{REF} - 0.50	V _{REF} - 0.47	V
Low comparator reset voltage of waveform shaping	V _{PBCTLLR}		V _{REF} - 0.33	V _{REF} - 0.30	V _{REF} - 0.27	V
Waveform shaping comparator Schmit width	V _{PBSH}		150	200	250	mV
High comparator voltage of CTL flag S	V _{FSL}		V _{REF} + 1.00	V _{REF} + 1.05	V _{REF} + 1.10	V
Low comparator voltage of CLT flag S	V _{FSL}		V _{REF} - 1.10	V _{REF} - 1.05	V _{REF} - 1.00	V
High comparator voltage of CTL flag L	V _{FLL}		V _{REF} + 1.40	V _{REF} + 1.45	V _{REF} + 1.50	V
Low comparator voltage of CTL flag L	V _{FLL}		V _{REF} - 1.50	V _{REF} - 1.45	V _{REF} - 1.40	V

CFG amplifier (AC coupling) (T_A = 25°C, V_{DD} = AV_{DD} = 5 V, V_{SS} = AV_{SS} = 0 V)

Parameter	Symbol	Condition	MIN.	TYP.	MAX.	Unit
Voltage gain 1	G _{CFG1}	f _i = 2 kHz, open loop	50			dB
Voltage gain 2	G _{CFG2}	f _i = 30 kHz, open loop	34			dB
CFGAMPO High-level output current	I _{OHCFG}	DC	-1			mA
CFGAMPO Low-level output current	I _{OLCFG}	DC	0.1			mA
High comparator voltage	V _{CFGH}		V _{REF} + 0.09	V _{REF} + 0.12	V _{REF} + 0.15	V
Low comparator voltage	V _{CFGH}		V _{REF} - 0.15	V _{REF} - 0.12	V _{REF} - 0.09	V
Duty accuracy	P _{DUTY}	Note	49.7	50.0	50.3	%

Note The conditions include the following circuit and input signal.

Input signal : Sine wave input (5 mV_{p-p})

f_i = 1 kHz

Voltage gain: 50 dB

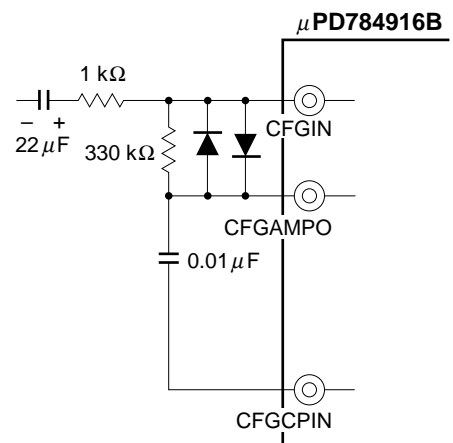

DFG amplifier (AC coupling) (T_A = 25°C, V_{DD} = AV_{DD} = 5 V, V_{SS} = AV_{SS} = 0 V)

Parameter	Symbol	Condition	MIN.	TYP.	MAX.	Unit
Voltage gain	G _{DFG}	f _i = 900 Hz, open loop	50			dB
Feedback resistance	R _{DFG}		160	400	640	kΩ
Input protection resistance	R _{IDFG}			150		Ω
High comparator voltage	V _{DFGH}		V _{REF} + 0.07	V _{REF} + 0.10	V _{REF} + 0.14	V
Low comparator voltage	V _{DFGL}		V _{REF} - 0.14	V _{REF} - 0.10	V _{REF} - 0.07	V

Caution Set the input resistance connected to the DFGIN pin to 16 kΩ or below. Connecting a resistor exceeding that value may cause the DFG amp to oscillate.

DPG comparator (AC coupling) (T_A = 25°C, V_{DD} = AV_{DD} = 5 V, V_{SS} = AV_{SS} = 0 V)

Parameter	Symbol	Condition	MIN.	TYP.	MAX.	Unit
Input impedance	Z _{IDPG}		20	50	100	kΩ
High comparator voltage	V _{DPGH}		V _{REF} + 0.02	V _{REF} + 0.05	V _{REF} + 0.08	V
Low comparator voltage	V _{DPGL}		V _{REF} - 0.08	V _{REF} - 0.05	V _{REF} - 0.02	V

Ternary separation circuit (T_A = 25°C, V_{DD} = AV_{DD} = 5 V, V_{SS} = AV_{SS} = 0 V)

Parameter	Symbol	Condition	MIN.	TYP.	MAX.	Unit
Input impedance	Z _{IPFG}		20	50	100	kΩ
High comparator voltage	V _{PFGH}		V _{REF} + 0.5	V _{REF} + 0.7	V _{REF} + 0.9	V
Low comparator voltage	V _{PFGL}		V _{REF} - 1.4	V _{REF} - 1.2	V _{REF} - 1.0	V

CSYNC comparator (AC coupling) (T_A = 25°C, V_{DD} = AV_{DD} = 5 V, V_{SS} = AV_{SS} = 0 V)

Parameter	Symbol	Condition	MIN.	TYP.	MAX.	Unit
Input impedance	Z _{ICSYN}		20	50	100	kΩ
High comparator voltage	V _{CSYNH}		V _{REF} + 0.07	V _{REF} + 0.10	V _{REF} + 0.13	V
Low comparator voltage	V _{CSYNL}		V _{REF} - 0.13	V _{REF} - 0.10	V _{REF} - 0.07	V

Reel FG comparator (AC coupling) (T_A = 25°C, V_{DD} = AV_{DD} = 5 V, V_{SS} = AV_{SS} = 0 V)

Parameter	Symbol	Condition	MIN.	TYP.	MAX.	Unit
Input impedance	Z _{IRLFG}		20	50	100	kΩ
High comparator voltage	V _{RFLFGH}		V _{REF} + 0.02	V _{REF} + 0.05	V _{REF} + 0.08	V
Low comparator voltage	V _{RFLFGL}		V _{REF} - 0.08	V _{REF} - 0.05	V _{REF} - 0.02	V

RECCTL driver (T_A = 25°C, V_{DD} = AV_{DD} = 5 V, V_{SS} = AV_{SS} = 0 V)

Parameter	Symbol	Condition	MIN.	TYP.	MAX.	Unit
RECCTL+, - high-level output voltage	V _{OHREC}	I _{OH} = -4 mA	V _{DD} - 0.8			V
RECCTL+, - low-level output voltage	V _{OLREC}	I _{OL} = 4 mA			0.8	V
CTLDLY internal resistance	R _{CTL}		40	70	140	kΩ
CTLDLY charge current	I _{OHCTL}	Use of internal resistor	-3			mA
CTLDLY discharge current	I _{OLCTL}		-3			mA

Timing waveform

AC timing test point

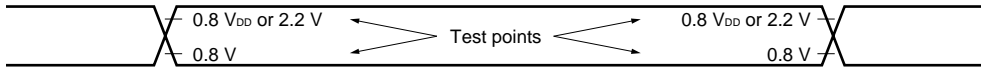

Serial transfer timing (SIO_n: n = 1 or 2)

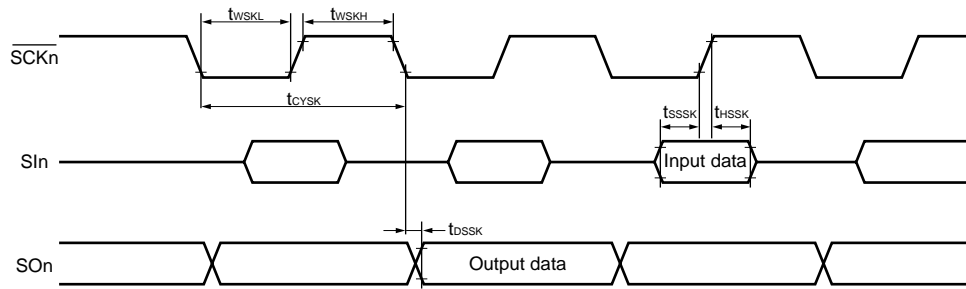

Serial transfer timing (SIO2 only)

No busy processing

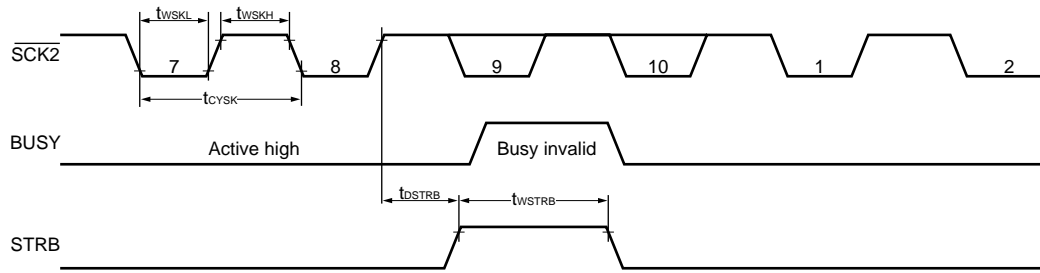

Continuation of busy processing

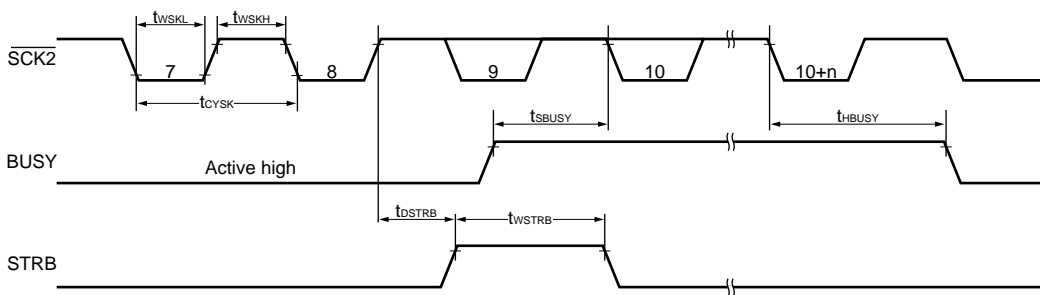

End of busy processing

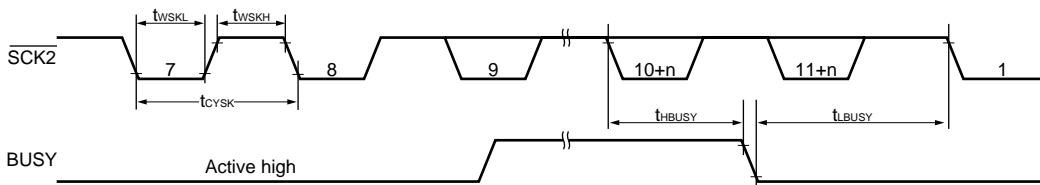

Caution When an external clock is selected as the serial clock, do not use the busy control or strobe control.

Super timer unit input timing

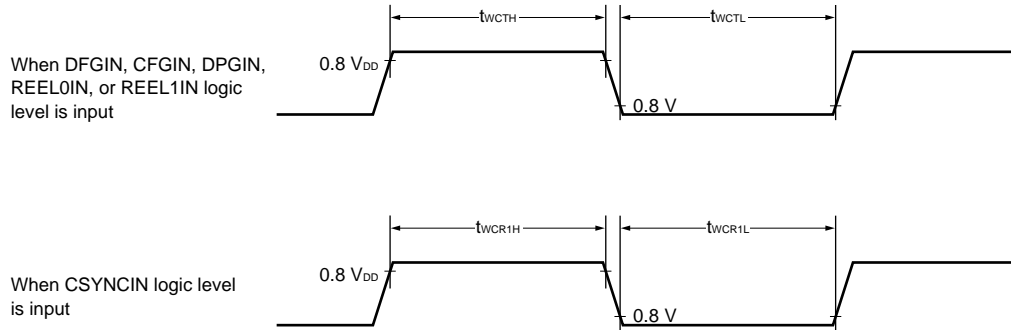

Interrupt input timing

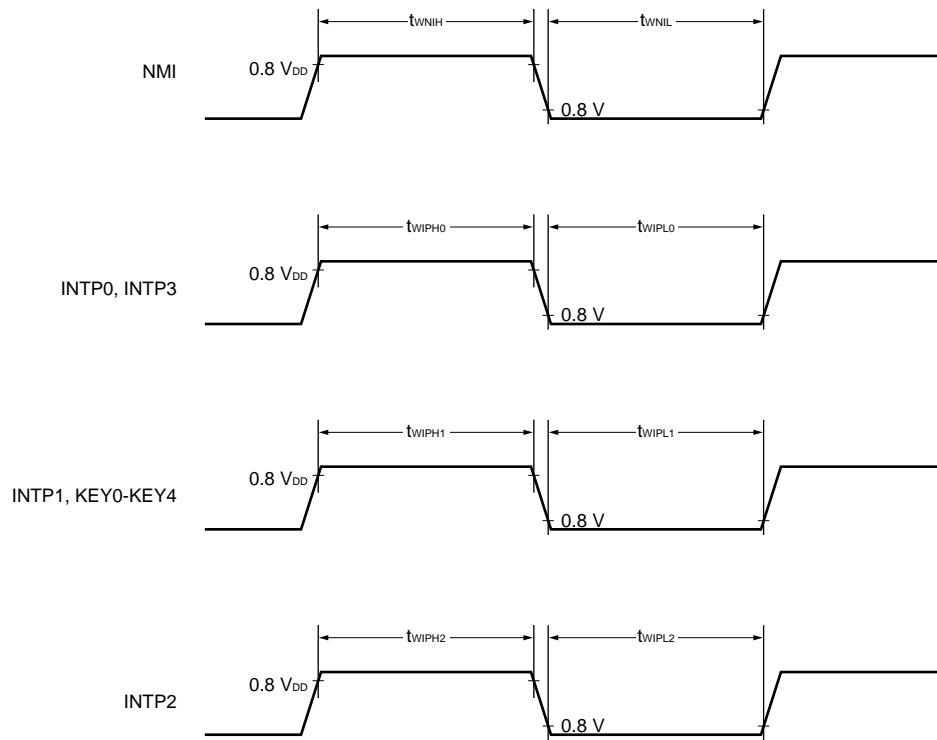

Reset input timing

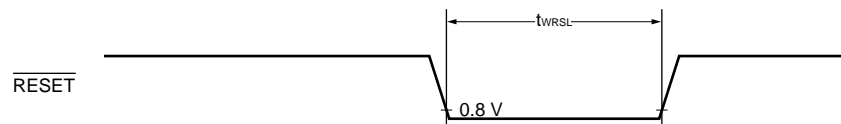

Clock output timing

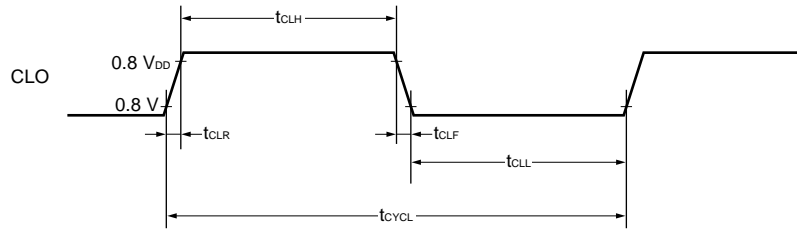

7. PACKAGE DRAWING

100 PIN PLASTIC QFP (14 × 20)

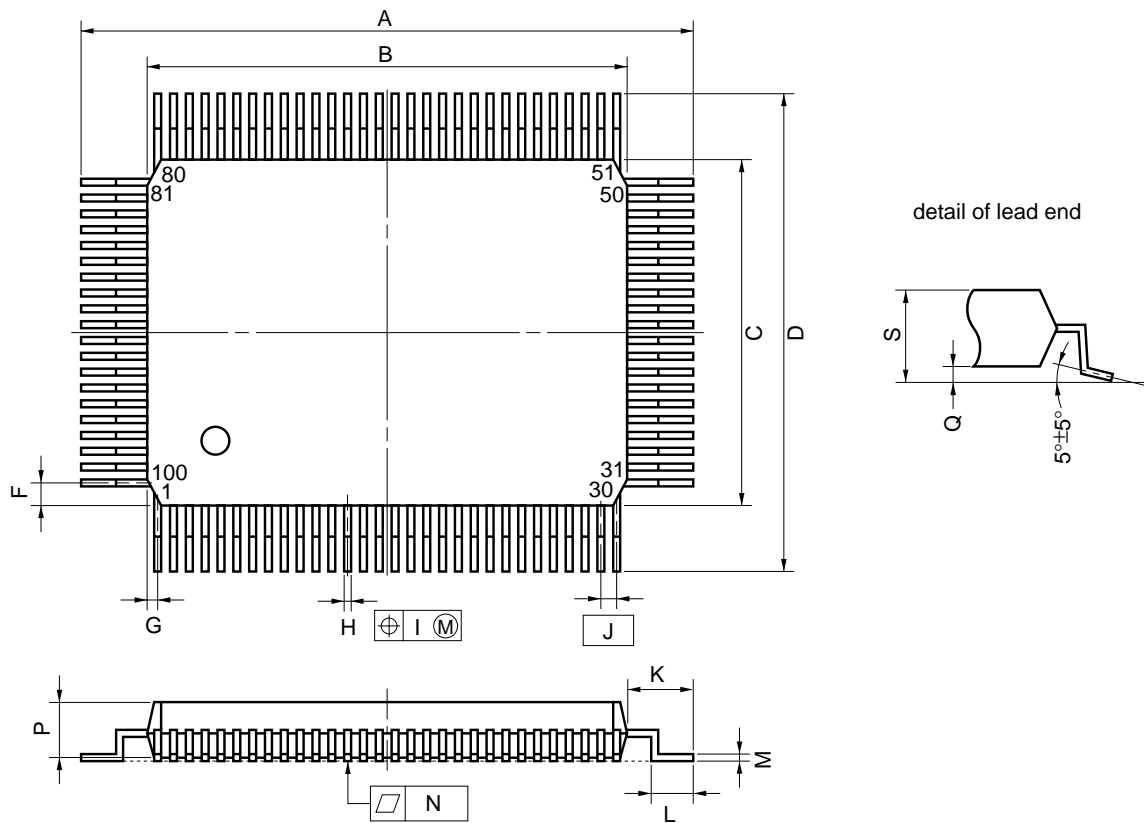

NOTE

Each lead centerline is located within 0.15 mm (0.006 inch) of its true position (T.P.) at maximum material condition.

Remark

External Dimensions of the ES version are the same as those of the mass-produced version.

P100GF-65-3BA1-2

ITEM	MILLIMETERS	INCHES
A	23.6±0.4	0.929±0.016
B	20.0±0.2	0.795 ^{+0.009} _{-0.008}
C	14.0±0.2	0.551 ^{+0.009} _{-0.008}
D	17.6±0.4	0.693±0.016
F	0.8	0.031
G	0.6	0.024
H	0.30±0.10	0.012 ^{+0.004} _{-0.005}
I	0.15	0.006
J	0.65 (T.P.)	0.026 (T.P.)
K	1.8±0.2	0.071 ^{+0.008} _{-0.009}
L	0.8±0.2	0.031 ^{+0.009} _{-0.008}
M	0.15 ^{+0.10} _{-0.05}	0.006 ^{+0.004} _{-0.003}
N	0.10	0.004
P	2.7	0.106
Q	0.1±0.1	0.004±0.004
S	3.0 MAX.	0.119 MAX.

8. RECOMMENDED SOLDERING CONDITIONS

The conditions listed below shall be met when soldering the μPD784915B and 784916B.

For details of the recommended soldering conditions, refer to the NEC document **Semiconductor Device Mounting Technology Manual (C10535E)**.

For soldering methods and conditions other than those recommended below, contact your NEC sales representative.

Table 18-1. Soldering Conditions for Surface-Mount Type

μPD784915BGF-xxx-3BA : 100-pin plastic QFP (14 × 20 mm)

μPD784916BGF-xxx-3BA : 100-pin plastic QFP (14 × 20 mm)

Soldering Method	Soldering Conditions	Recommended Condition Symbol
Infrared reflow	Package peak temperature: 235°C, Duration: 30 sec. max. (at 210°C or above), Number of times: 3 times max.	IR35-00-3
VPS	Package peak temperature: 215°C, Duration: 40 sec. max. (at 200°C or above), Number of times: 3 times max.	VP15-00-3
Wave soldering	Solder bath temperature: 260°C max. Duration: 10 sec. max. Number of times: Once Preliminary heat temperature: 120°C max. (Package surface temperature)	WS60-00-1
Partial heating	Pin temperature: 300°C max., Duration: 3 sec. max. (per pin row)	-

Caution Using more than one soldering method should be avoided (except in the case of partial heating).

APPENDIX A. DEVELOPMENT TOOLS

The following development tools are available for system development using the μPD784916B.
 Also refer to **(5) Cautions on Using Development Tools**.

(1) Language Processing Software

RA78K4	Assembler package common to 78K/IV Series
CC78K/4	C compiler package common to 78K/IV Series
DF784915	Device file for μPD784915 Subseries
CC78K/4-L	C compiler library source file common to 78K/IV Series

(2) PROM Programming Tools

PG-1500	PROM programmer
PA-78P4916GF	Program adapter connected to PG-1500.
PG-1500 controller	Control program for PG-1500

(3) Debugging Tools

IE-784000-R	In-circuit emulator common to 78K/IV Series
IE-784000-R-EM	Emulation board common to 78K/IV Series
IE-70000-98-IF-B IE-70000-98-IF-C ^{Note}	Interface adapter required when using PC-9800 series (except notebook PCs) as host machine
IE-70000-98N-IF-B	Interface adapter and cable required when using PC-9800 series (except notebook PCs) as host machine.
IE-70000-PC-IF-B IE-70000-PC-IF-C ^{Note}	Interface adapter required when using IBM PC/AT or compatible as host machine.
IE-78000-R-SV3	Interface adapter and cable required when using EWS as host machine.
IE-784915-R-EM1	Emulation board for emulating μPD784915 Subseries
EP-784915GF-R	Emulation probe for μPD784915 Subseries
EV-9200GF-100	Socket to be mounted on target system board manufactured for 100-pin plastic QFP (GF-3BA type). Used for LCC packages.
NQPACK100RB	Socket to be mounted on target system board manufactured for 100-pin plastic QFP (GF-3BA type). Used for QFP packages.
ID78K4	Integrated debugger for IE-784000-R.
SM78K4	System simulator common to 78K/IV Series
DF784915	Device file for μPD784915 Subseries

Note Under development

(4) Real-Time OS

RX78K/IV	Real-time OS for 78K/IV Series
MX78K4	OS for 78/IV Series

(5) Cautions on Using Development Tools

- Use the ID78K4, SM78K4 in combination with the DF784915.
- Use the CC78K4, RX78K/IV in combination with the RA78K4 and DF784915.
- The NQPACK100RB is a product made by TOKYO ELETECH CORPORATION.
Tokyo Electronic Components Division (TEL(03)3820-7112)
Osaka Electronic Components Division (TEL(06)244-6672)
- The host machines and OS supported by each software product are as follows.

Host Machine [OS]	PC PC-9800 series [Windows™] IBM PC/AT and Compatibles [Japanese/English Windows]	EWS HP9000 series 700™ [HP-UX™] SPARCstation™ [SunOS™] NEWS™ (RISC) [NEWS-OS™]
Software		
RA78K4	√ <i>Note</i>	√
CC78K4	√ <i>Note</i>	√
PG-1500 controller	√ <i>Note</i>	—
ID78K4	√	√
SM78K4	√	—
RX78K/IV	√ <i>Note</i>	√
MX78K4	√ <i>Note</i>	√

Note DOS-based software

APPENDIX B. RELATED DOCUMENTS

Documents related to devices

Document Name	Document Number	
	Japanese	English
μPD784915 Subseries User's manual — Hardware	U10444J	U10444E
μPD784915 Data Sheet	U11044J	U11044E
μPD784915A, 784916A Data Sheet	U11022E	U11022J
μPD784915B, 784916B Data Sheet	U13118J	This document
μPD78P4916 Data Sheet	U11045J	U11045E
μPD784915 Subseries Application Note	U11361J	U11361E
μPD784915 Subseries Special function register table	U10976J	—
78K/IV Series User's manual — Instruction	U10905J	U10905E
78K/IV Series Instruction table	U10594J	—
78K/IV Series Instruction set	U10595J	—
78K/IV Series Application note — Software basics	U10095J	U10095E

Documents related to development tools (user's manual)

Document Name		Document Number	
		Japanese	English
RA78K4 Series Assembler package	Language	U11162J	U11162E
	Operation	U11334J	U11334E
RA78K4 Series Structured assembler preprocessor		U11743J	U11743E
CC78K4 C compiler	Language	U11571J	U11571E
	Operation	U11572J	U11572E
CC78K Series Library source file		U12322J	—
PG-1500 PROM Programmer		U11940J	EEU-1335
PG-1500 Controller PC-9800 series (MS-DOS™) based		EEU-704	EEU-1291
PG-1500 Controller IBM PC series (PC DOS™) based		EEU-5008	U10540E
IE-784000-R		U12903J	EEU-1534
IE-784915-R-EMI, EP-784915-GF-R		U10931J	U10931E
SM78K4 System Simulator Windows based	Reference	U10093J	U10093E
SM78K Series System Simulator	External parts user open interface specifications	U10092J	U10092E
ID78K4 Integrated debugger - Windows based	Reference	U10440J	U10440E
ID78K4 Integrated debugger - HP-UX, SunOS, NEWS-OS based	Reference	U11960J	U11960E

Caution The above related documents are subject to change without notice. Be sure to read the latest version of documents before designing.

Documents related to embedded software (user's manual)

Document Name		Document Number	
		Japanese	English
RX78K/IV Real-time OS	Basics	U10603J	U10603E
	Installation	U10604J	U10604E
	Debugger	U10364J	—
78K/IV Series OS MX78K4	Fundamental	U11779J	—

Other related documents

Document Name		Document Number	
		Japanese	English
IC package manual		C10943X	
Semiconductor Device Mounting Technology Manual		C10535J	C10535E
Quality Grades on NEC Semiconductor Devices		C11531J	C11531E
NEC Semiconductor Device Reliability/Quality Control System		C10983J	C10983E
Guide to prevent damage for Semiconductor Devices by Electrostatic Discharge (ESD)		C11892J	C11892E
Guide to Quality Assurance for Semiconductor Devices		—	MEI-1202
Microcomputer Product Series Guide		U11416J	—

Caution The above related documents are subject to change without notice. Be sure to read the latest version of documents before designing.

[MEMO]

NOTES FOR CMOS DEVICES

① PRECAUTION AGAINST ESD FOR SEMICONDUCTORS

Note: Strong electric field, when exposed to a MOS device, can cause destruction of the gate oxide and ultimately degrade the device operation. Steps must be taken to stop generation of static electricity as much as possible, and quickly dissipate it once, when it has occurred. Environmental control must be adequate. When it is dry, humidifier should be used. It is recommended to avoid using insulators that easily build static electricity. Semiconductor devices must be stored and transported in an anti-static container, static shielding bag or conductive material. All test and measurement tools including work bench and floor should be grounded. The operator should be grounded using wrist strap. Semiconductor devices must not be touched with bare hands. Similar precautions need to be taken for PW boards with semiconductor devices on it.

② HANDLING OF UNUSED INPUT PINS FOR CMOS

Note: No connection for CMOS device inputs can be cause of malfunction. If no connection is provided to the input pins, it is possible that an internal input level may be generated due to noise, etc., hence causing malfunction. CMOS device behave differently than Bipolar or NMOS devices. Input levels of CMOS devices must be fixed high or low by using a pull-up or pull-down circuitry. Each unused pin should be connected to V_{DD} or GND with a resistor, if it is considered to have a possibility of being an output pin. All handling related to the unused pins must be judged device by device and related specifications governing the devices.

③ STATUS BEFORE INITIALIZATION OF MOS DEVICES

Note: Power-on does not necessarily define initial status of MOS device. Production process of MOS does not define the initial operation status of the device. Immediately after the power source is turned ON, the devices with reset function have not yet been initialized. Hence, power-on does not guarantee out-pin levels, I/O settings or contents of registers. Device is not initialized until the reset signal is received. Reset operation must be executed immediately after power-on for devices having reset function.

Regional Information

Some information contained in this document may vary from country to country. Before using any NEC product in your application, please contact the NEC office in your country to obtain a list of authorized representatives and distributors. They will verify:

- Device availability
- Ordering information
- Product release schedule
- Availability of related technical literature
- Development environment specifications (for example, specifications for third-party tools and components, host computers, power plugs, AC supply voltages, and so forth)
- Network requirements

In addition, trademarks, registered trademarks, export restrictions, and other legal issues may also vary from country to country.

NEC Electronics Inc. (U.S.)

Santa Clara, California
Tel: 408-588-6000
800-366-9782
Fax: 408-588-6130
800-729-9288

NEC Electronics (Germany) GmbH

Duesseldorf, Germany
Tel: 0211-65 03 02
Fax: 0211-65 03 490

NEC Electronics (UK) Ltd.

Milton Keynes, UK
Tel: 01908-691-133
Fax: 01908-670-290

NEC Electronics Italiana s.r.l.

Milano, Italy
Tel: 02-66 75 41
Fax: 02-66 75 42 99

NEC Electronics (Germany) GmbH

Benelux Office
Eindhoven, The Netherlands
Tel: 040-2445845
Fax: 040-2444580

NEC Electronics (France) S.A.

Velizy-Villacoublay, France
Tel: 01-30-67 58 00
Fax: 01-30-67 58 99

NEC Electronics (France) S.A.

Spain Office
Madrid, Spain
Tel: 01-504-2787
Fax: 01-504-2860

NEC Electronics (Germany) GmbH

Scandinavia Office
Taeby, Sweden
Tel: 08-63 80 820
Fax: 08-63 80 388

NEC Electronics Hong Kong Ltd.

Hong Kong
Tel: 2886-9318
Fax: 2886-9022/9044

NEC Electronics Hong Kong Ltd.

Seoul Branch
Seoul, Korea
Tel: 02-528-0303
Fax: 02-528-4411

NEC Electronics Singapore Pte. Ltd.

United Square, Singapore 1130
Tel: 253-8311
Fax: 250-3583

NEC Electronics Taiwan Ltd.

Taipei, Taiwan
Tel: 02-719-2377
Fax: 02-719-5951

NEC do Brasil S.A.

Cumbica-Guarulhos-SP, Brasil
Tel: 011-6465-6810
Fax: 011-6465-6829

The documents referred to in this publication may include preliminary versions. However, preliminary versions are not marked as such.

FIP is a registered trademark of NEC Corporation.

MS-DOS and Windows are either trademarks or registered trademarks of Microsoft Corporation in the United States and/or other countries.

PC/AT, and PC-DOS are trademarks of International Business Machines Corporation.

HP9000 series 700 and HP-UX are trademarks of Hewlett-Packard Company.

SPARCstation is a trademark of SPARC International, Inc.

SunOS is a trademark of Sun Microsystems, Inc.

NEWS and NEW-OS are trademarks of Sony Corporation.

The export of this product from Japan is regulated by the Japanese government. To export this product may be prohibited without governmental license, the need for which must be judged by the customer. The export or re-export of this product from a country other than Japan may also be prohibited without a license from that country. Please call an NEC sales representative.

The application circuits and their parameters are for reference only and are not intended for use in actual design-in's.

No part of this document may be copied or reproduced in any form or by any means without the prior written consent of NEC Corporation. NEC Corporation assumes no responsibility for any errors which may appear in this document.

NEC Corporation does not assume any liability for infringement of patents, copyrights or other intellectual property rights of third parties by or arising from use of a device described herein or any other liability arising from use of such device. No license, either express, implied or otherwise, is granted under any patents, copyrights or other intellectual property rights of NEC Corporation or others.

While NEC Corporation has been making continuous effort to enhance the reliability of its semiconductor devices, the possibility of defects cannot be eliminated entirely. To minimize risks of damage or injury to persons or property arising from a defect in an NEC semiconductor device, customers must incorporate sufficient safety measures in its design, such as redundancy, fire-containment, and anti-failure features.

NEC devices are classified into the following three quality grades:

"Standard", "Special", and "Specific". The Specific quality grade applies only to devices developed based on a customer designated "quality assurance program" for a specific application. The recommended applications of a device depend on its quality grade, as indicated below. Customers must check the quality grade of each device before using it in a particular application.

Standard: Computers, office equipment, communications equipment, test and measurement equipment, audio and visual equipment, home electronic appliances, machine tools, personal electronic equipment and industrial robots

Special: Transportation equipment (automobiles, trains, ships, etc.), traffic control systems, anti-disaster systems, anti-crime systems, safety equipment and medical equipment (not specifically designed for life support)

Specific: Aircrafts, aerospace equipment, submersible repeaters, nuclear reactor control systems, life support systems or medical equipment for life support, etc.

The quality grade of NEC devices is "Standard" unless otherwise specified in NEC's Data Sheets or Data Books. If customers intend to use NEC devices for applications other than those specified for Standard quality grade, they should contact an NEC sales representative in advance.

Anti-radioactive design is not implemented in this product.