

## SINGLE-CHIP MICROCONTROLLER WITH ON-CHIP PRESCALER, PLL FREQUENCY SYNTHESIZER, AND IF COUNTER FOR CAR-MOUNTED FM/MW/LW RADIO

### DESCRIPTION

$\mu$ PD17012GF-055 is 4-bit CMOS microcontroller for PLL frequency synthesizer-method digital tuning, which is capable of receiving European FM, MW, and LW.

The external appearance is 64-pin plastic QFP in which the prescaler (150 MHz MAX.), PLL frequency synthesizer, and IF counter are integrated. Also, since it can use various RDS (Radio Data System) functions in the FM band, it is possible for a car-mounted stereo and the high-performance multi-functional FM, MW, and LW tuner to be configured in a single chip.

### FEATURES

- Can receive European FW, MW, and LW bands.
- Preset memory of 6 stations in FM1, FM2, and AM, respectively (thus totaling 18 stations)
- One last-channel station memory for each band, FM1, FM2, and AM
- Rich in station-select functions, such as selection of stations through MANUAL or AUTO-SEEK UP/DOWN, preset memory scan, auto store memory (sorting stations with strong SD signals in the order of frequency), etc.
- RDS decode function
- Traffic information stand-by (TA/DK stand-by) function
- $\mu$ PD16431A is used for the LCD controller/driver
- Clock function with 12- or 24-hour display (No-clock also possible)
- Program name display function based on RDS-broadcast data
- AF function for 25 stations, handling methods A and B
- Supporting electronic volume
- Supporting detachable panel
- 5 V  $\pm$  10 %: single power supply

### ORDERING INFORMATION

Part Number	Package
$\mu$ PD17012GF-055-3BE	64-pin plastic QFP (14 $\times$ 20 mm)

The information in this document is subject to change without notice.

**FUNCTION OVERVIEW**

**Receive Frequency, Channel Space, Reference Frequency, Intermediate Frequency**

Item Band	Receive Frequency	Channel Space	Reference Frequency	Intermediate Frequency
FM	87.50 – 108.00 MHz	50 kHz	50 kHz	10.7 MHz
MW	522 – 1620 kHz	9 kHz	9 kHz	450 kHz 459 kHz 10.71 MHz
LW	144 – 281 kHz	1 kHz	1 kHz	450 kHz 459 kHz 10.71 MHz

**Channel Selection Function**

(1) Manual tuning

Type	Description
Manual up / Manual down	Pressing the key once moves the frequency up/down by a step. Keeping the key pressed for over 0.5 second will result in fast forward.

(2) Auto tuning

Type	Description
Seek up / Seek down	Searches for broadcasting stations in up/down directions. If a station is detected, the frequency of the station is retained. In RDS mode, only RDS broadcasting stations are searched for. In TP/SK mode, only traffic information stations are searched for.

(3) Preset memory

Data on 6 broadcasting stations can be stored for each of the bands (FM1, FM2, AM), totaling 24 stations.

(4) Auto store memory

Broadcasting stations are searched for starting from the lowest frequency. Detected stations are written in preset memory starting from the highest SD level. Afterwards, they are sorted in order of the frequency.

(5) Last channel memory

Equipped with last channel memory independently for each of the FM1, FM2, and AM bands.

(6) Auto retuning

If no SD signal can be detected for about 20 seconds or longer during reception of a broadcasting station, auto retuning is started automatically.

(7) TP/SK auto retuning

If no SD or TP/SK signal is detected for 30 seconds or longer in TP/SK mode during reception of a broadcasting station, auto retuning to detect TP/SK stations is started automatically.

### RDS Function

- (1) Broadcasting station name display  
Displays the name of the broadcasting station whose programs are currently being received, by using the PS code.
- (2) AF operation  
AF list of up to 25 stations can be incorporated to handle METHOD A and METHOD B.
- (3) Switchover to a traffic information station  
TA or TP data detected during TP/SK stand-by cause a switch to a traffic information station.
- (4) PTY alarm  
If a PTY code (= 31) alarm is received, "AL ARM" is displayed and the sound is switched to the tuner.
- (5) RDS memory  
Equipped with RDS memory for 14 stations, namely, preset memory for 6 stations each in FM1 and FM2, and the last channel memory for each of FM1 and FM2.

### Clock Function

- (1) Capable of 12-hr (with "AM" and "PM" showing) and 24-hr displays.
- (2) Use of a flashing colon (":") (1 Hz) can be selected.
- (3) In no-clock mode, backup is possible with low power consumption.

### Tape Function

- (1) Sound switchover can be made by tape signal input.
- (2) The tape run direction can be displayed.
- (3) Capable of noise reduction output
- (4) Metal tape compatible

### CD Function

- (1) Capable of sound switchover by CD signal input

### Electronic Volume Function

- (1) The values of volume/bass/treble/balance/fader can be set.
- (2) Supporting attenuator/loudness

PIN CONFIGURATION (TOP VIEW)

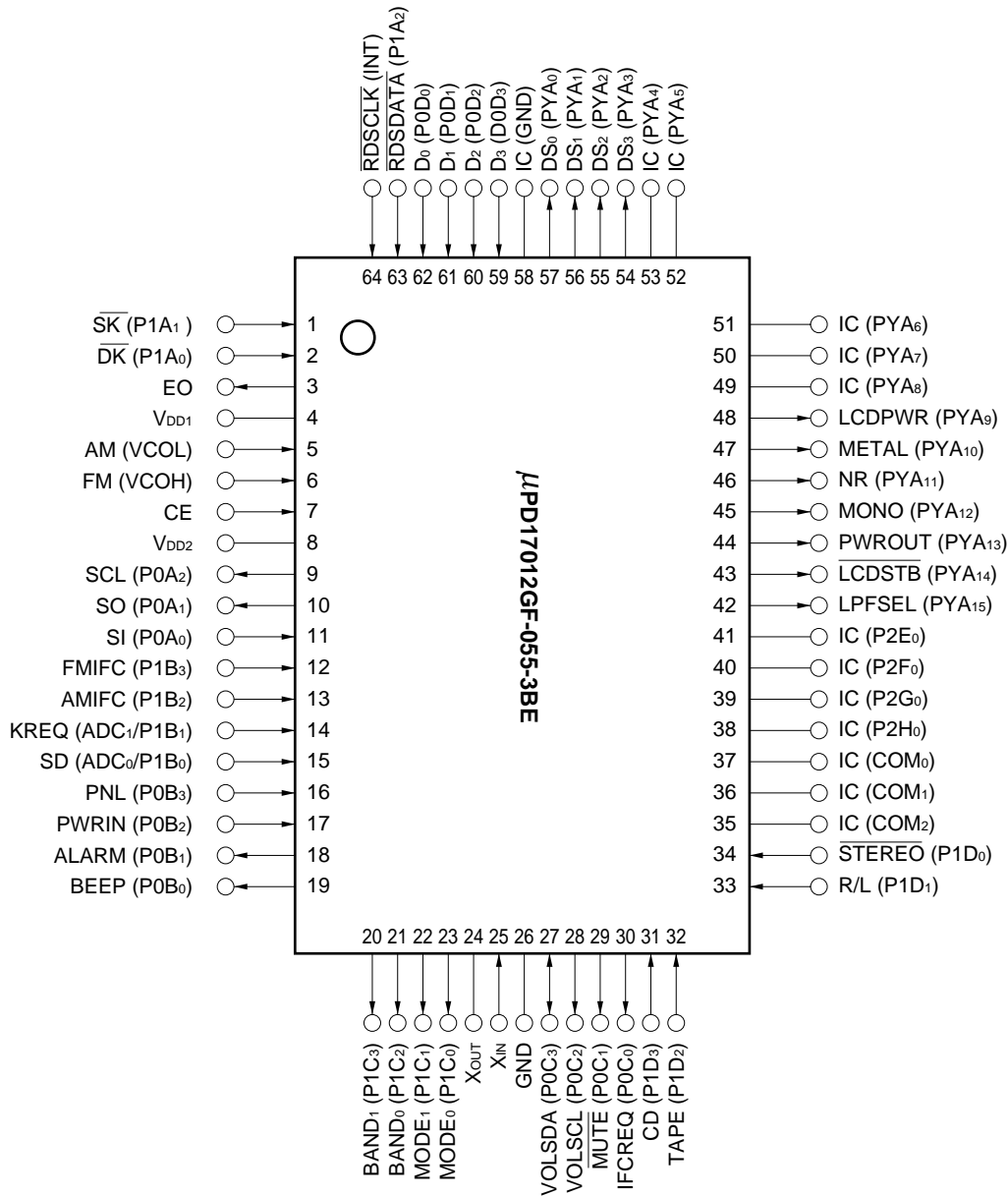

**Caution** Connect “IC” pin to GND directly.

- Remarks**
1. IC: internally connected pins
  2. ( ): Applies to the μPD17012GF pins.

CONTENTS

1. PIN FUNCTIONS ..... 7

2. KEY MATRIX CONFIGURATION ..... 12

    2.1 Allocation of Initialize Diode Matrix ..... 12

    2.2 Connection of Initialize Diode Matrix ..... 12

    2.3 Allocation of Momentary Key Matrix ..... 13

    2.4 Description of Key Matrix ..... 14

        2.4.1 Initialize diode matrix ..... 14

        2.4.2 Momentary key ..... 18

3. MODE TRANSITIONS ..... 28

4. DATA OUTPUT TO LCD CONTROLLER/DRIVER (μPD16431A) ..... 29

    4.1 Data Input/Output Timing ..... 30

5. RDS (Radio Data System) FUNCTION ..... 33

    5.1 RDS Data Incorporation ..... 33

    5.2 RDS Data Processing ..... 34

        5.2.1 PI (Program Identification) ..... 34

        5.2.2 PS (Program Service Name) ..... 35

        5.2.3 PTY (Program Type) ..... 35

        5.2.4 AF (Alternative Frequency) ..... 35

        5.2.5 TP (Traffic Program Identification), TA (Traffic Announcement Identification) ..... 40

6. MUTE TIMING ..... 41

    6.1 Tuner Operation ..... 41

        6.1.1 Preset memory reading ..... 41

        6.1.2 Preset scan ..... 44

        6.1.3 Preset memory writing ..... 44

        6.1.4 Seek up/down ..... 46

        6.1.5 Manual up/down ..... 49

        6.1.6 Auto store memory ..... 50

        6.1.7 AF switchover ..... 51

    6.2 Mode Switchover ..... 54

        6.2.1 RADIO mode ↔ TAPE/CD mode ..... 54

        6.2.2 Traffic information broadcasting/PTY alarm ↔ TAPE/CD mode (TP/SK mode) ..... 55

    6.3 CE Pin ..... 55

        6.3.1 Low level → high level ..... 55

        6.3.2 High level → low level ..... 55

    6.4 Detecting the Detachable Panel ..... 56

    6.5 Power Control ..... 57

        6.5.1 Timing of POWER ON ↔ OFF transitions by POWER key ..... 57

        6.5.2 Timing of POWER ON ↔ POWER OFF transitions by detachable panel ..... 58

7. LCD PANEL ..... 59

    7.1 LCD Panel Configuration ..... 59

    7.2 LCD Pin Assignment ..... 59

    7.3 Description of LCD Panel Display ..... 62

8. SYSTEM CONFIGURATION EXAMPLE ..... 68

9. ELECTRICAL SPECIFICATIONS (PRELIMINARY) ..... 69

10. PACKAGE DRAWING ..... 72

11. RECOMMENDED SOLDERING CONDITIONS ..... 73

**APPENDIX DESCRIPTION OF ELECTRONIC VOLUME CONTROL ..... 74**

**Appendix 1. Function of Electronic Volume ..... 74**

**Appendix 2. Description of the Electronic Volume Control ..... 74**

**Appendix 3. Initial Electronic Volume Value Settings ..... 75**

**Appendix 4. Electronic Volume Data Output Timing ..... 76**

        Appendix 4.1 Initial data setting output timing ..... 76

        Appendix 4.2 Volume data output timing ..... 77

        Appendix 4.3 Loudness data output timing ..... 77

        Appendix 4.4 Attenuator data output timing ..... 78

        Appendix 4.5 Sound source switchover data output timing ..... 79

        Appendix 4.6 Bass data output timing ..... 79

        Appendix 4.7 Treble data output timing ..... 80

1. PIN FUNCTIONS

Pin No.	Symbol	Pin Name	Description	I/O Format
1	$\overline{SK}$	$\overline{SK}$ signal input	This input pin detects the $\overline{SK}$ signal (traffic information broadcasting station identification) of a VF broadcasting station. It is output at low level. If VF broadcasting stations are not in use, please pull it up.	Input
2	$\overline{DK}$	$\overline{DK}$ signal input	This input pin detects the $\overline{DK}$ signal (traffic information on-air identification) of a VF broadcasting station. It is output at low level. If VF broadcasting stations are not in use, pull it up.	Input
3	EO	Error out	This refers to the output from the charge pump of the PLL frequency synthesizer. If the value which has divided the local oscillator frequency is higher than the reference frequency, high level is output from these pins. If the value is lower, low level is output. If the value is the same as the reference frequency, it results in floating.	CMOS 3-state output
4 8	$V_{DD1}$ $V_{DD2}$	Power input	This is the pin for positive power. It supplies the 5 V $\pm$ 10% voltage when running the CPU and peripheral devices. It is possible to retain data at 2.2 V when the clock has stopped. When $V_{DD}$ is started up, the device is reset by the built-in power-ON reset circuit. Avoid applying a voltage higher than $V_{DD}$ to any pins other than $V_{DD}$ ( $V_{DD1}$ , $V_{DD2}$ ). Be careful about this especially when simultaneously starting up the $V_{DD}$ and CE pins, because application of a higher voltage may cause latch-up. Ensure that the $V_{DD1}$ pin and the $V_{DD2}$ pin are connected to the same electric potential.	—
5	AM	AM local oscillation input	This pin is for inputting the local oscillation output (VCO output) of the AM (MW, LW) band. When the MW or LW band is received, the pin becomes active; in other cases, it is internally pulled down. The inputtable frequency range is 0.5 to 30 MHz (0.3 $V_{p-p}$ ). Since the pin connects to a built-in AC amplifier, please use a capacitor to cut out the DC portion before inputting.	Input
6	FM	FM local oscillation input	This pin is for inputting the local oscillation output (VCO output) of the FM band. When the FM band is received, the pin becomes active; in other cases, it is internally pulled down. The inputtable frequency range is 9 to 150 MHz (0.3 $V_{p-p}$ ). Since the pin connects to a built-in AC amplifier, please use a capacitor to cut out the DC portion before inputting.	Input
7	CE	Chip enable	This is the device selection signal input pin. To make a device perform usual operations (such as radio, tape, CD, clock), high level is input. At low level, this pin is placed in the backup state, with the radio, tape, and CD turned OFF. It is possible to place this pin in the backup state with low current consumption by turning off the clock display (initialize diode NOCLK = 1).	Input

Pin No.	Symbol	Pin Name	Description	I/O Format								
9	SCL	Clock signal output	This is the LCD controller/driver (μPD16431A) clock signal output pin.	CMOS push-pull output								
10	SO	Serial data output	This is the LCD controller/driver (μPD16431A) serial data output pin. For the connection to the μPD16431A, refer to <b>Figure 4-1. μPD16431A Pin Configuration.</b>	CMOS push-pull output								
11	SI	Serial data input	This is the LCD controller/driver (μPD16431A) serial data input pin. Connect pull-up resistor externally.	CMOS push-pull								
12	FMIFC	FM intermediate frequency input	<p>This is the intermediate frequency (IF) input pin for the FM band.</p> <p>The inputtable frequency range is 5 to 15 MHz (0.3 V<sub>P-P</sub>). Since the pin connects to a built-in AC amplifier, use a capacitor to cut out the DC portion before inputting. This pin is used to detect the presence/absence of a broadcasting station during auto tuning when the initialize diode is set to “FM SD/IF switch = 1”.</p> <p>The input frequency condition for determining that there is a broadcasting station is as follows:</p> <table border="1" style="margin-left: auto; margin-right: auto;"> <thead> <tr> <th>Band</th> <th>Input Frequency Range</th> </tr> </thead> <tbody> <tr> <td>FM</td> <td>10.7 MHz ± 12.5 kHz</td> </tr> </tbody> </table> <p>The input frequency range refers to the frequency range in which input must be made within 10 ms after PLL is locked.</p>	Band	Input Frequency Range	FM	10.7 MHz ± 12.5 kHz	Input				
Band	Input Frequency Range											
FM	10.7 MHz ± 12.5 kHz											
13	AMIFC	AM intermediate frequency input	<p>This is the intermediate frequency (IF) input pin for the AM band.</p> <p>The inputtable frequency range is 0.1 to 1.0 MHz (0.3 V<sub>P-P</sub>). Since the pin connects to a built-in AC amplifier, please use a capacitor to cut out the DC portion before inputting. This pin is used to detect the presence/absence of a broadcasting station during auto tuning when the initialize diode is set to “AM SD/IF switch = 1”.</p> <p>The input frequency condition for determining that there is a broadcasting station is as follows:</p> <table border="1" style="margin-left: auto; margin-right: auto;"> <thead> <tr> <th>Band</th> <th>Input Frequency Range</th> </tr> </thead> <tbody> <tr> <td rowspan="2">MW</td> <td>450 kHz ± 3 kHz</td> </tr> <tr> <td>459 kHz ± 3 kHz</td> </tr> <tr> <td rowspan="2">LW</td> <td>450 kHz ± 3 kHz</td> </tr> <tr> <td>459 kHz ± 3 kHz</td> </tr> </tbody> </table> <p>The input frequency range refers to the frequency range in which input must be made within 10 ms after PLL is locked.</p>	Band	Input Frequency Range	MW	450 kHz ± 3 kHz	459 kHz ± 3 kHz	LW	450 kHz ± 3 kHz	459 kHz ± 3 kHz	Input
Band	Input Frequency Range											
MW	450 kHz ± 3 kHz											
	459 kHz ± 3 kHz											
LW	450 kHz ± 3 kHz											
	459 kHz ± 3 kHz											
14	KREQ	Key request signal input	This input pin detects the key request signal of LCD controller/driver μPD16431A. Key detection occurs at high level.	Input								



Pin No.	Symbol	Pin Name	Description	I/O Format												
15	SD	Station detection signal input	<p>This is the input pin for detecting broadcasting station detection signal.</p> <p>This pin is used to detect the presence of a broadcasting station during auto-tuning.</p> <p>Also, for the case where initialization diode RETUNE = 0, if, while receiving a broadcasting station, this pin is at less than the SD input voltage continuously for at least about 20 seconds, an upward seek operation is started.</p> <p>After the PLL has locked, if a voltage greater than the SD input voltage is applied during the SD stabilization wait period, SD is assumed present.</p> <p>In RDS mode in the FM band, the pin is checked as one of the conditions for the start of AF operation.</p>	Input												
16	PANEL	Panel detach detection signal input	<p>This is the detachable panel detection signal input pin.</p> <p>Low level is interpreted as panel in the mounted state; high level is interpreted as panel in the detached state.</p>	Input												
17	PWRIN	Power key input	<p>This is the input pin for power key.</p> <p>It turns the power ON/OFF at the rising edge.</p> <p>Also, it operates the same as the <b>POWER</b> key of the momentary key.</p>	Input												
18	ALARM	Traffic information alarm output	<p>This is the output pin for traffic information alarm.</p> <p>When there is no traffic information station identification signal in the TP/SK mode in the FM band, an alarm sound with a frequency of 3 kHz is output on and off about every 0.5 second.</p>	CMOS push-pull output												
19	BEEP	Beep output	<p>This is the beep output pin.</p> <p>It outputs about 40 ms of square waves with frequency of 3 kHz and duty factor of 50 %.</p> <p>The beeping sound is issued in the following cases:</p> <ol style="list-style-type: none"> <li>① When a valid key is pressed</li> <li>② When the hold of about 5 seconds during a preset scanning operation is ended</li> <li>③ When writing is performed in preset memory.</li> </ol>	CMOS push-pull output												
20 21	BAND <sub>1</sub> BAND <sub>0</sub>	Band switchover signal output	<p>This is the band switchover signal output pin.</p> <p>If a new receiving band is switched to by means of the band switchover key, depending on the band, the following output.</p> <table border="1" style="margin-left: auto; margin-right: auto;"> <thead> <tr> <th>Band \ Pin</th> <th>BAND<sub>0</sub></th> <th>BAND<sub>1</sub></th> </tr> </thead> <tbody> <tr> <td>MW</td> <td>0</td> <td>0</td> </tr> <tr> <td>LW</td> <td>1</td> <td>0</td> </tr> <tr> <td>FM</td> <td>×</td> <td>1</td> </tr> </tbody> </table> <p>(0 : low level 1 : high level × : don't care)</p>	Band \ Pin	BAND <sub>0</sub>	BAND <sub>1</sub>	MW	0	0	LW	1	0	FM	×	1	CMOS push-pull output
Band \ Pin	BAND <sub>0</sub>	BAND <sub>1</sub>														
MW	0	0														
LW	1	0														
FM	×	1														
22 23	MODE <sub>1</sub> MODE <sub>0</sub>	Mode signal output	<p>These output pins show the operation mode of the μPD17012GF-055. The modes are as follows:</p> <table border="1" style="margin-left: auto; margin-right: auto;"> <thead> <tr> <th>Mode</th> <th>MODE<sub>0</sub></th> <th>MODE<sub>1</sub></th> </tr> </thead> <tbody> <tr> <td>Tuner</td> <td>0</td> <td>0</td> </tr> <tr> <td>CD</td> <td>0</td> <td>1</td> </tr> <tr> <td>Tape</td> <td>1</td> <td>0</td> </tr> </tbody> </table> <p>(0 : low level 1 : high level)</p>	Mode	MODE <sub>0</sub>	MODE <sub>1</sub>	Tuner	0	0	CD	0	1	Tape	1	0	CMOS push-pull output
Mode	MODE <sub>0</sub>	MODE <sub>1</sub>														
Tuner	0	0														
CD	0	1														
Tape	1	0														

Pin No.	Symbol	Pin Name	Description	I/O Format						
24 25	X <sub>OUT</sub> X <sub>IN</sub>	Crystal resonator	This pin is for connecting the crystal resonator. A 4.5-MHz crystal resonator is connected. When using the clock function, the precision of the oscillator frequency affects that of the clock. Adjust the oscillator frequency while observing the PLL local oscillator frequency.	CMOS push-pull input						
26	GND	Ground	This is the ground pin.	—						
27	VOLSDA	Electronic volume data input/output	This is the serial data I/O pin with electronic volume. Because this is an N-ch open-drain output, connect pull-up resistor externally.	N-ch open-drain output						
28	VOLSCL	Electronic volume data output	This is the serial data input pin with electronic volume. Because this is an N-ch open-drain output, connect pull-up resistor externally.	N-ch open-drain output						
29	MUTE	MUTE signal output	This is the sound MUTE signal output pin. It is output at low level. It is used to remove the shock noise occurring when the PLL lock is not in place in RADIO mode, or to switchover the MODE pin output. For this is N-ch open-drain output, connect pull-up resistor externally.	N-ch open-drain output						
30	IFCREQ	IF count request signal output	This is the IF count request signal output pin. It outputs high-level with SD during seek. Because this is an N-ch open-drain output, connect pull-up resistor externally.	N-ch open-drain output						
31	CD	CD play signal input	This is the CD play signal input pin. By inputting high level to this pin, the sound source (MODE output) can be switched to CD. The CD play signal takes precedence over the tape signal.	Input						
32	TAPE	Tape signal input	This is the tape signal input pin. By inputting high level to this pin, the sound source (MODE output) can be switched to tape.	Input						
33	R/L	Tape run signal input	This is the tape run signal input pin. It is used for display on the LCD panel. Enter data as follows. <table border="1" style="margin: 10px auto;"> <thead> <tr> <th>R/L Pin</th> <th>Tape Run Direction</th> </tr> </thead> <tbody> <tr> <td>Low level</td> <td>Left → right</td> </tr> <tr> <td>High level</td> <td>Right → left</td> </tr> </tbody> </table>	R/L Pin	Tape Run Direction	Low level	Left → right	High level	Right → left	Input
R/L Pin	Tape Run Direction									
Low level	Left → right									
High level	Right → left									
34	STEREO	Stereo signal input	This is the stereo signal input signal. Enter data as follows. <table border="1" style="margin: 10px auto;"> <thead> <tr> <th>STEREO Pin</th> <th>Description</th> </tr> </thead> <tbody> <tr> <td>Low level</td> <td>Stereo broadcasting</td> </tr> <tr> <td>High level</td> <td>Monaural broadcasting</td> </tr> </tbody> </table> Bands other than FM are invalid.	STEREO Pin	Description	Low level	Stereo broadcasting	High level	Monaural broadcasting	Input
STEREO Pin	Description									
Low level	Stereo broadcasting									
High level	Monaural broadcasting									
35-41, 49-53, 58	IC	Internal connection	Connect this pin to the GND directly.	—						

Pin No.	Symbol	Pin Name	Description	I/O Format
42	LPFSEL	LPF time-constant switchover signal output	<p>This signal output pin is for switching over the LPF time-constant of the tuner during AF operation. During AF operation, high level is output as shown below.</p> <p>① PLL lock wait time</p>	CMOS push-pull output
43	LCDSTB	Strobe signal output	This is the LCD controller/driver (μPD16431A) strobe signal output pin. This is output at low level.	CMOS push-pull output
44	PWROUT	Power-ON detection signal output	This is the power-ON detection signal output pin.	CMOS push-pull output
45	MONO	Monaural output	This is the monaural output pin.	CMOS push-pull output
46	NR	Noise reduction output	This is the noise reduction output pin.	CMOS push-pull output
47	METAL	Metal output	This is the metal output pin.	CMOS push-pull output
48	LCDPWR	LCD power output	This is the power signal output pin of the LCD controller/driver (μPD16431A).	CMOS push-pull output
54   57	DS <sub>3</sub>   DS <sub>0</sub>	Initialize diode source signal output	This is the source signal output pin of the initialize diode matrix.	CMOS push-pull output
59   62	D <sub>3</sub>   D <sub>0</sub>	Initialize diode return signal input	This is the return signal input terminal of the initialize diode matrix.	Input with pull-down resistor
63	RDSDATA	RDS data signal input	This is the RDS data signal input pin. Please input the data signal from the RDS signal detection part. Data is read on the falling edge of the RDS clock.	Input
64	RDSCLK	RDS clock input	This is the RDS clock input pin. Please enter the clock signal from the RDS signal detection part. Please input as accurate a clock as possible, because bit synchronization detection by clock signal width is not performed in the μPD17012GF-055.	Input

2. KEY MATRIX CONFIGURATION

2.1 Allocation of Initialize Diode Matrix

Input Pin \ Output Pin	DS <sub>3</sub> (54)	DS <sub>2</sub> (55)	DS <sub>1</sub> (56)	DS <sub>0</sub> (57)
D <sub>0</sub> (62)	FM SD/IF	AM SD/IF	AMIF1	AMIF2
D <sub>1</sub> (61)	CLK24	FLASH	NOCLK	RETUNE
D <sub>2</sub> (60)	MESEL	PRIDISP	VOLFUNC	PRIMANU
D <sub>3</sub> (59)	CLKDSP	—	—	—

2.2 Connection of Initialize Diode Matrix

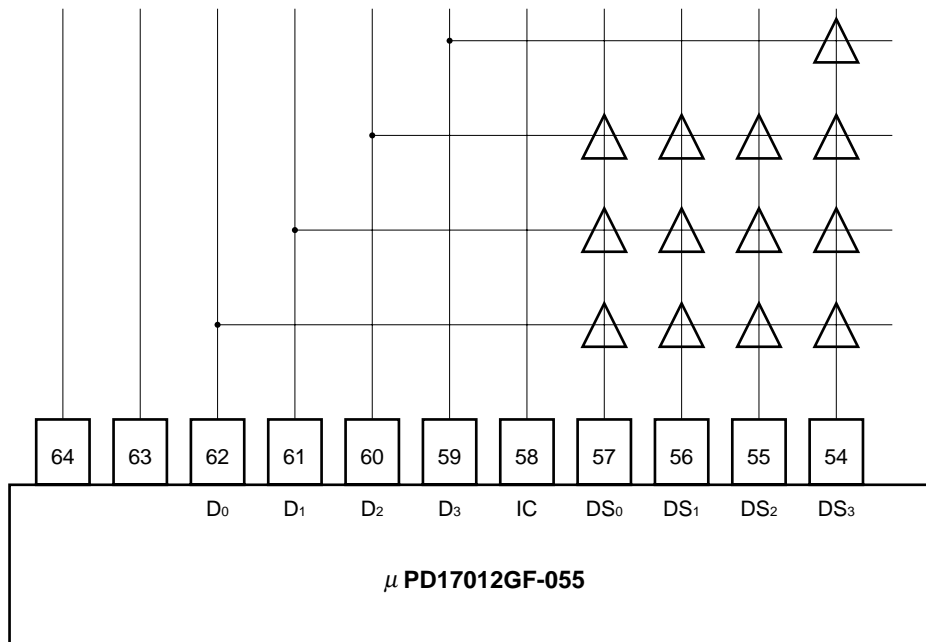
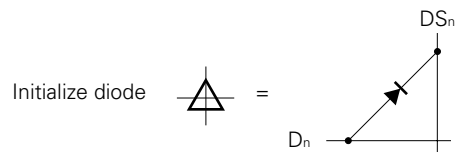

**2.3 Allocation of Momentary Key Matrix**

- **KS1-KS7** : Key source signal output (connected to pins 25-31 of μPD16431A)
- **KEY1-KEY4**: Key return signal input (connected to pins 2-5 of μPD16431A)

	KS1	KS2	KS3	KS4	KS5	KS6	KS7
KEY1	M1	M2	M3	M4	M5	M6	POWER
KEY2	PSCAN	ASM	MONO	PI	NR	METAL	—
KEY3	RDS	TP/SK	ME	DISP	SEEKUP (MANU.UP)	SEEKDOWN (MANU.DOWN)	—
KEY4	BAND	AUTO	ATT/LOUD	SELECT	VOLUP	VOLDOWN	—

**Remark** The values in the parentheses are valid only when the mode is set to SHIFT mode by the SHIFT key.

## 2.4 Description of Key Matrix

### 2.4.1 Initialize diode matrix

The initialize diode matrix contains the following 18 types (43 items). All these types are read only when the power is initially turned on (power-ON reset) to the V<sub>DD</sub> pin on when the CE pin is changed from low level to high level. At other times, they are ignored.

**(1) Switch for setting the method of detecting broadcasting stations in auto tuning.**

FM SD/IF, AM SD/IF

**(2) Switch for setting the intermediate frequency of the AM band**

AMIF1, AMIF2

**(3) Switch for setting clock functions**

CLK24, FLASH, NOCLK, CLKDSP

**(4) Switch for selecting between ON/OFF of auto retune**

RETUNE

**(5) Switch for setting the  key**

MESEL

**(6) Switch for selecting whether a priority display should be made**

PRIDISP

**(7) Switch for selecting electronic volume source switching**

VOLFUNC

**(8) Switch for selecting the tuning mode**

PRIMANU

These switches are set on the matrix after short-circuiting it with diodes.

Functions of the initialize diode matrix are described on the following pages. For the diodes, "1" indicates short-circuited; and "0" indicates open.

Symbol	Description of Functions												
FM SD/IF	<p>This switch sets the method of detecting broadcasting stations during auto tuning of the FM band. It is set as follows:</p> <table border="1"> <thead> <tr> <th>FM SD/IF</th> <th>Methods of Detecting Broadcasting Stations</th> </tr> </thead> <tbody> <tr> <td>0</td> <td>SD only used</td> </tr> <tr> <td>1</td> <td>SD and IF counter</td> </tr> </tbody> </table> <p>(1: Short-circuited with diode    0: Open)</p>	FM SD/IF	Methods of Detecting Broadcasting Stations	0	SD only used	1	SD and IF counter						
FM SD/IF	Methods of Detecting Broadcasting Stations												
0	SD only used												
1	SD and IF counter												
AM SD/IF	<p>This switch sets the method of detecting broadcasting stations during auto tuning of the AM band. It is set as follows:</p> <table border="1"> <thead> <tr> <th>AM SD/IF</th> <th>Methods of Detecting Broadcasting Stations</th> </tr> </thead> <tbody> <tr> <td>0</td> <td>SD only used</td> </tr> <tr> <td>1</td> <td>SD and IF counter</td> </tr> </tbody> </table> <p>(1: Short-circuited with diode    0: Open)</p>	AM SD/IF	Methods of Detecting Broadcasting Stations	0	SD only used	1	SD and IF counter						
AM SD/IF	Methods of Detecting Broadcasting Stations												
0	SD only used												
1	SD and IF counter												
AMIF1 AMIF2	<p>This switch sets the intermediate frequency of the AM (MW, LW) band. It is set as follows:</p> <table border="1"> <thead> <tr> <th>AMIF1</th> <th>AMIF2</th> <th>Intermediate Frequency</th> </tr> </thead> <tbody> <tr> <td>0</td> <td>0</td> <td>450 kHz</td> </tr> <tr> <td>0</td> <td>1</td> <td>459 kHz</td> </tr> <tr> <td>1</td> <td>×</td> <td>10.71 MHz</td> </tr> </tbody> </table> <p>(1: Short-circuited with diode    0: Open    × : Don't care)</p>	AMIF1	AMIF2	Intermediate Frequency	0	0	450 kHz	0	1	459 kHz	1	×	10.71 MHz
AMIF1	AMIF2	Intermediate Frequency											
0	0	450 kHz											
0	1	459 kHz											
1	×	10.71 MHz											
CLK24	<p>This switch selects a 12-hour or 24-hour clock display. It is set as follows:</p> <table border="1"> <thead> <tr> <th>CLK24</th> <th>Clock Display</th> </tr> </thead> <tbody> <tr> <td>0</td> <td>12-hr display (with "AM", "PM" display)</td> </tr> <tr> <td>1</td> <td>24-hr display</td> </tr> </tbody> </table> <p>(1: Short-circuited with diode    0: Open)</p>	CLK24	Clock Display	0	12-hr display (with "AM", "PM" display)	1	24-hr display						
CLK24	Clock Display												
0	12-hr display (with "AM", "PM" display)												
1	24-hr display												
FLASH	<p>This switch sets the colon lighting in the clock display. It is set as follows:</p> <table border="1"> <thead> <tr> <th>FLASH</th> <th>Colon (:) Display</th> </tr> </thead> <tbody> <tr> <td>0</td> <td>Always ON</td> </tr> <tr> <td>1</td> <td>Flash Frequency : 1 Hz Duty factor : 60 %</td> </tr> </tbody> </table> <p>(1: Short-circuited with diode    0: Open)</p>	FLASH	Colon (:) Display	0	Always ON	1	Flash Frequency : 1 Hz Duty factor : 60 %						
FLASH	Colon (:) Display												
0	Always ON												
1	Flash Frequency : 1 Hz Duty factor : 60 %												

Symbol	Description of Functions						
NOCLK	<p>This switch sets the clock function. It is set as follows:</p> <table border="1" data-bbox="358 321 1344 485"> <thead> <tr> <th>NOCLK</th> <th>Setting of Clock Functions</th> </tr> </thead> <tbody> <tr> <td>0</td> <td>Clock present</td> </tr> <tr> <td>1</td> <td>Clock absent. In this case, the FLASH, CLK24, and CLKDSP switches are ignored.</td> </tr> </tbody> </table> <p>(1: Short-circuited with diode 0: Open)</p>	NOCLK	Setting of Clock Functions	0	Clock present	1	Clock absent. In this case, the FLASH, CLK24, and CLKDSP switches are ignored.
NOCLK	Setting of Clock Functions						
0	Clock present						
1	Clock absent. In this case, the FLASH, CLK24, and CLKDSP switches are ignored.						
RETUNE	<p>This switch selects ON/OFF of the auto retune. It is set as follows:</p> <table border="1" data-bbox="358 663 1336 793"> <thead> <tr> <th>RETUNE</th> <th>Auto Retune</th> </tr> </thead> <tbody> <tr> <td>0</td> <td>On</td> </tr> <tr> <td>1</td> <td>Off</td> </tr> </tbody> </table> <p>(1: Short-circuited with diode 0: Open)</p>	RETUNE	Auto Retune	0	On	1	Off
RETUNE	Auto Retune						
0	On						
1	Off						
MESEL	<p>This switch sets whether the <input type="checkbox"/> <b>ME</b> key is valid or not. It is set as follows:</p> <table border="1" data-bbox="358 976 1336 1106"> <thead> <tr> <th>MESEL</th> <th><input type="checkbox"/> <b>ME</b> key</th> </tr> </thead> <tbody> <tr> <td>0</td> <td>Invalid</td> </tr> <tr> <td>1</td> <td>Valid</td> </tr> </tbody> </table> <p>(1: Short-circuited with diode 0: Open)</p>	MESEL	<input type="checkbox"/> <b>ME</b> key	0	Invalid	1	Valid
MESEL	<input type="checkbox"/> <b>ME</b> key						
0	Invalid						
1	Valid						
PRIDISP	<p>This switch selects whether a priority display should be made or not. For details of the priority display, please refer to the description of the <input type="checkbox"/> <b>DISP</b> key. The PRIDISP switch is set as follows:</p> <table border="1" data-bbox="358 1323 1336 1455"> <thead> <tr> <th>PRIDISP</th> <th>Priority Display</th> </tr> </thead> <tbody> <tr> <td>0</td> <td>Absent</td> </tr> <tr> <td>1</td> <td>Present</td> </tr> </tbody> </table> <p>(1: Short-circuited with diode 0: Open)</p>	PRIDISP	Priority Display	0	Absent	1	Present
PRIDISP	Priority Display						
0	Absent						
1	Present						
VOLFUNC	<p>This switch selects transmission of the sound source switching data to electronic volume. It is set as follows:</p> <table border="1" data-bbox="354 1635 1336 1766"> <thead> <tr> <th>VOLFUNC</th> <th>Transmission of the Sound Source Switching Data to Electronic Volume</th> </tr> </thead> <tbody> <tr> <td>0</td> <td>Not transmit</td> </tr> <tr> <td>1</td> <td>Transmit</td> </tr> </tbody> </table> <p>(1: Short-circuited with diode 0: Open)</p>	VOLFUNC	Transmission of the Sound Source Switching Data to Electronic Volume	0	Not transmit	1	Transmit
VOLFUNC	Transmission of the Sound Source Switching Data to Electronic Volume						
0	Not transmit						
1	Transmit						



Symbol	Description of Functions												
PRIMANU	<p>This switch sets auto/manual mode at the start. Set as follows.</p> <table border="1" data-bbox="431 323 1416 457"> <thead> <tr> <th>PRIMANU</th> <th>Auto/Manual Mode</th> </tr> </thead> <tbody> <tr> <td>0</td> <td>Auto mode</td> </tr> <tr> <td>1</td> <td>Manual mode</td> </tr> </tbody> </table> <p>(1: Short-circuited with diode    0: Open)</p>	PRIMANU	Auto/Manual Mode	0	Auto mode	1	Manual mode						
PRIMANU	Auto/Manual Mode												
0	Auto mode												
1	Manual mode												
CLKDSP	<p>This key selects display/non-display of clock in the power-off state caused by the <span style="border: 1px solid black; padding: 2px;">POWER</span> key. Set as follows.</p> <table border="1" data-bbox="431 638 1416 772"> <thead> <tr> <th>CLKDSP</th> <th>Display of Clock in the Power-off State</th> </tr> </thead> <tbody> <tr> <td>0</td> <td>Display</td> </tr> <tr> <td>1</td> <td>Non-display</td> </tr> </tbody> </table> <p>(1: Short-circuited with diode    0: Open)</p> <p>When initial setting diode NOCLK = 1, although display of clock is selected, clock is not displayed. Initial setting diode CLKDSP is linked with the control of power supply (LCDPWR pin) to LCD controller/driver (μPD16431A) in the power-off state. The states are shown below.</p> <table border="1" data-bbox="431 995 1416 1192"> <thead> <tr> <th>CLKDSP</th> <th>Description</th> </tr> </thead> <tbody> <tr> <td>0</td> <td>No power is supplied to LCD driver/controller (μPD16431A) in the power-off state. (LCDPWR pin goes to low level)</td> </tr> <tr> <td>1</td> <td>Power is supplied to LCD driver/controller (μPD16431A) in the power-off state. (LCDPWR pin goes to high level)</td> </tr> </tbody> </table> <p>(1: Short-circuited with diode    0: Open)</p>	CLKDSP	Display of Clock in the Power-off State	0	Display	1	Non-display	CLKDSP	Description	0	No power is supplied to LCD driver/controller (μPD16431A) in the power-off state. (LCDPWR pin goes to low level)	1	Power is supplied to LCD driver/controller (μPD16431A) in the power-off state. (LCDPWR pin goes to high level)
CLKDSP	Display of Clock in the Power-off State												
0	Display												
1	Non-display												
CLKDSP	Description												
0	No power is supplied to LCD driver/controller (μPD16431A) in the power-off state. (LCDPWR pin goes to low level)												
1	Power is supplied to LCD driver/controller (μPD16431A) in the power-off state. (LCDPWR pin goes to high level)												

2.4.2 Momentary key

Symbol	Description of Functions
<div style="display: flex; flex-direction: column; gap: 5px;"> <div style="border: 1px solid black; padding: 2px; text-align: center;">M1</div> <div style="border: 1px solid black; padding: 2px; text-align: center;">M2</div> <div style="border: 1px solid black; padding: 2px; text-align: center;">M3</div> <div style="border: 1px solid black; padding: 2px; text-align: center;">M4</div> <div style="border: 1px solid black; padding: 2px; text-align: center;">M5</div> <div style="border: 1px solid black; padding: 2px; text-align: center;">M6</div> </div>	<p>Performs reading or writing of the preset memory. The read/write procedure differs depending on the MESEL switch of the initialize diode.</p> <ul style="list-style-type: none"> <li>• If MESEL = 0: If keys <span style="border: 1px solid black; padding: 0 5px;">M1</span> to <span style="border: 1px solid black; padding: 0 5px;">M6</span> are released within 2 seconds, it will result in a memory read operation. If they are kept pressed for 2 seconds or longer, it will result in memory write operation.</li> <li>• If MESEL = 1: If the key is pressed while the ME segment of the LCD display is lit, it results in a memory write operation. If the key is pressed while the ME segment of the LCD display is unlit, it results in a memory read operation.</li> </ul> <p>If the station to be received is an RDS station, the PI code of the station is also memorized by the preset memory write operation. If the PI code is memorized in the preset memory, and the frequency cannot be received or the received PI code is different from that of the station, the PI search starts seeking the station that meets the stop condition, searching from the preset frequency upward. If it detects the station, it will receive from the station. If no station meets the stop condition, the PI search retains the initial frequency. When preset memory is called or written, band/preset is displayed for 5 seconds.</p>
<div style="border: 1px solid black; padding: 2px; text-align: center;">POWER</div>	<p>This is the power key. By pressing this key, it switches power-ON/OFF.</p>

Symbol	Description of Functions												
<div style="border: 1px solid black; padding: 2px; width: fit-content; margin-bottom: 5px;"><b>PSCAN</b></div>	<p>This is the preset memory scan operation key.                      By pressing this key, preset scan operation starts.                      If a preset memory is currently being received, reception is made from the next memory (for example, from M4 if M3 is being received).                      In other cases, each preset memory is received for five seconds sequentially starting from memory 1.                      It is valid only in RADIO mode.                      If the preset station is an RDS broadcasting station, AF operation is performed but not PI searching.                      During the 5-second reception period, no RDS operations such as AF judgment are performed.                      During preset scan operation, "PSCAN" display is lit on the LCD panel. The operation of each key during a scan operation is shown below.</p> <table border="1" data-bbox="480 648 1448 1409"> <thead> <tr> <th data-bbox="483 653 708 690">Key</th> <th data-bbox="708 653 1445 690">Description of Operations</th> </tr> </thead> <tbody> <tr> <td data-bbox="483 690 708 772"> <div style="border: 1px solid black; padding: 2px; width: fit-content; margin-bottom: 2px;"><b>PSCAN</b></div> </td> <td data-bbox="708 690 1445 772">The preset scan operation is stopped and the frequency when the key was pressed is retained.</td> </tr> <tr> <td data-bbox="483 772 708 884"> <div style="border: 1px solid black; padding: 2px; width: fit-content; margin-bottom: 2px;"><b>M1</b></div> <div style="text-align: center; margin-bottom: 2px;"> </div> <div style="border: 1px solid black; padding: 2px; width: fit-content;"><b>M6</b></div> </td> <td data-bbox="708 772 1445 884">The preset scan operation is stopped, and preset memory of the pressed key is called.</td> </tr> <tr> <td data-bbox="483 884 708 1026"> <div style="border: 1px solid black; padding: 2px; width: fit-content; margin-bottom: 2px;"><b>SEEKUP</b></div> <div style="border: 1px solid black; padding: 2px; width: fit-content; margin-bottom: 2px;"><b>SEEKDOWN</b></div> <div style="border: 1px solid black; padding: 2px; width: fit-content; margin-bottom: 2px;"><b>BAND</b></div> <div style="border: 1px solid black; padding: 2px; width: fit-content;"><b>ASM</b></div> </td> <td data-bbox="708 884 1445 1026">The preset scan operation is stopped, and the operation of the pressed key is performed.</td> </tr> <tr> <td data-bbox="483 1026 708 1203"> <div style="border: 1px solid black; padding: 2px; width: fit-content; margin-bottom: 2px;"><b>AUTO</b></div> <div style="border: 1px solid black; padding: 2px; width: fit-content; margin-bottom: 2px;"><b>SELECT</b></div> <div style="border: 1px solid black; padding: 2px; width: fit-content; margin-bottom: 2px;"><b>VOLUP</b></div> <div style="border: 1px solid black; padding: 2px; width: fit-content; margin-bottom: 2px;"><b>VOLDOWN</b></div> <div style="border: 1px solid black; padding: 2px; width: fit-content;"><b>ATT/LOUD</b></div> </td> <td data-bbox="708 1026 1445 1203">The preset scan operation is continued. The operation of the pressed key is performed.</td> </tr> <tr> <td data-bbox="483 1203 708 1409"> <div style="border: 1px solid black; padding: 2px; width: fit-content; margin-bottom: 2px;"><b>TP/SK</b></div> <div style="border: 1px solid black; padding: 2px; width: fit-content; margin-bottom: 2px;"><b>RDS</b></div> <div style="border: 1px solid black; padding: 2px; width: fit-content; margin-bottom: 2px;"><b>PI</b></div> <div style="border: 1px solid black; padding: 2px; width: fit-content;"><b>MONO</b></div> </td> <td data-bbox="708 1203 1445 1409"> <ul style="list-style-type: none"> <li>• Upon reception of FM band The preset scan operation is continued. The operation of the pressed key is performed.</li> <li>• Upon reception of AM band The preset scan operation is continued. The operation of the pressed key becomes invalid.</li> </ul> </td> </tr> </tbody> </table>	Key	Description of Operations	<div style="border: 1px solid black; padding: 2px; width: fit-content; margin-bottom: 2px;"><b>PSCAN</b></div>	The preset scan operation is stopped and the frequency when the key was pressed is retained.	<div style="border: 1px solid black; padding: 2px; width: fit-content; margin-bottom: 2px;"><b>M1</b></div> <div style="text-align: center; margin-bottom: 2px;"> </div> <div style="border: 1px solid black; padding: 2px; width: fit-content;"><b>M6</b></div>	The preset scan operation is stopped, and preset memory of the pressed key is called.	<div style="border: 1px solid black; padding: 2px; width: fit-content; margin-bottom: 2px;"><b>SEEKUP</b></div> <div style="border: 1px solid black; padding: 2px; width: fit-content; margin-bottom: 2px;"><b>SEEKDOWN</b></div> <div style="border: 1px solid black; padding: 2px; width: fit-content; margin-bottom: 2px;"><b>BAND</b></div> <div style="border: 1px solid black; padding: 2px; width: fit-content;"><b>ASM</b></div>	The preset scan operation is stopped, and the operation of the pressed key is performed.	<div style="border: 1px solid black; padding: 2px; width: fit-content; margin-bottom: 2px;"><b>AUTO</b></div> <div style="border: 1px solid black; padding: 2px; width: fit-content; margin-bottom: 2px;"><b>SELECT</b></div> <div style="border: 1px solid black; padding: 2px; width: fit-content; margin-bottom: 2px;"><b>VOLUP</b></div> <div style="border: 1px solid black; padding: 2px; width: fit-content; margin-bottom: 2px;"><b>VOLDOWN</b></div> <div style="border: 1px solid black; padding: 2px; width: fit-content;"><b>ATT/LOUD</b></div>	The preset scan operation is continued. The operation of the pressed key is performed.	<div style="border: 1px solid black; padding: 2px; width: fit-content; margin-bottom: 2px;"><b>TP/SK</b></div> <div style="border: 1px solid black; padding: 2px; width: fit-content; margin-bottom: 2px;"><b>RDS</b></div> <div style="border: 1px solid black; padding: 2px; width: fit-content; margin-bottom: 2px;"><b>PI</b></div> <div style="border: 1px solid black; padding: 2px; width: fit-content;"><b>MONO</b></div>	<ul style="list-style-type: none"> <li>• Upon reception of FM band The preset scan operation is continued. The operation of the pressed key is performed.</li> <li>• Upon reception of AM band The preset scan operation is continued. The operation of the pressed key becomes invalid.</li> </ul>
Key	Description of Operations												
<div style="border: 1px solid black; padding: 2px; width: fit-content; margin-bottom: 2px;"><b>PSCAN</b></div>	The preset scan operation is stopped and the frequency when the key was pressed is retained.												
<div style="border: 1px solid black; padding: 2px; width: fit-content; margin-bottom: 2px;"><b>M1</b></div> <div style="text-align: center; margin-bottom: 2px;"> </div> <div style="border: 1px solid black; padding: 2px; width: fit-content;"><b>M6</b></div>	The preset scan operation is stopped, and preset memory of the pressed key is called.												
<div style="border: 1px solid black; padding: 2px; width: fit-content; margin-bottom: 2px;"><b>SEEKUP</b></div> <div style="border: 1px solid black; padding: 2px; width: fit-content; margin-bottom: 2px;"><b>SEEKDOWN</b></div> <div style="border: 1px solid black; padding: 2px; width: fit-content; margin-bottom: 2px;"><b>BAND</b></div> <div style="border: 1px solid black; padding: 2px; width: fit-content;"><b>ASM</b></div>	The preset scan operation is stopped, and the operation of the pressed key is performed.												
<div style="border: 1px solid black; padding: 2px; width: fit-content; margin-bottom: 2px;"><b>AUTO</b></div> <div style="border: 1px solid black; padding: 2px; width: fit-content; margin-bottom: 2px;"><b>SELECT</b></div> <div style="border: 1px solid black; padding: 2px; width: fit-content; margin-bottom: 2px;"><b>VOLUP</b></div> <div style="border: 1px solid black; padding: 2px; width: fit-content; margin-bottom: 2px;"><b>VOLDOWN</b></div> <div style="border: 1px solid black; padding: 2px; width: fit-content;"><b>ATT/LOUD</b></div>	The preset scan operation is continued. The operation of the pressed key is performed.												
<div style="border: 1px solid black; padding: 2px; width: fit-content; margin-bottom: 2px;"><b>TP/SK</b></div> <div style="border: 1px solid black; padding: 2px; width: fit-content; margin-bottom: 2px;"><b>RDS</b></div> <div style="border: 1px solid black; padding: 2px; width: fit-content; margin-bottom: 2px;"><b>PI</b></div> <div style="border: 1px solid black; padding: 2px; width: fit-content;"><b>MONO</b></div>	<ul style="list-style-type: none"> <li>• Upon reception of FM band The preset scan operation is continued. The operation of the pressed key is performed.</li> <li>• Upon reception of AM band The preset scan operation is continued. The operation of the pressed key becomes invalid.</li> </ul>												

Symbol	Description of Functions						
<p style="text-align: center;"><b>ASM</b></p>	<p>This is the auto store memory operation key. It is valid only in RADIO mode.</p> <p>If it is pressed, a search is made from the lowest frequency to the highest frequency of the relevant band to write six stations into preset memory in ascending order of the frequency, starting from the station whose SD is strongest.</p> <p>If the searched station is an RDS, PI code of the station is stored simultaneously.</p> <p>Data on the detected broadcasting stations are written to one preset memory after another, starting from preset memory 1. If the maximum frequency is reached before the six stations are written, the previous frequencies stay in the remaining preset memories.</p> <p>If this key is pressed again during the auto store memory operation, the operation is suspended. However, the broadcasting stations which have already been detected are written in the preset memory. During auto store memory operation, the band received and ASM are displayed. The operation of each key during an auto store memory operation is shown below.</p> <table border="1" data-bbox="402 611 1370 947"> <thead> <tr> <th data-bbox="402 611 630 653">Key</th> <th data-bbox="630 611 1370 653">Description of Operations</th> </tr> </thead> <tbody> <tr> <td data-bbox="402 653 630 800"> <p style="text-align: center;"><b>ASM</b></p> </td> <td data-bbox="630 653 1370 800"> <p>The auto store memory operation is stopped, and if more than one station is found, M1 is received.</p> <p>If no station is found, the frequency at the beginning of the operation is received.</p> </td> </tr> <tr> <td data-bbox="402 800 630 947"> <p style="text-align: center;"><b>SELECT</b></p> <p style="text-align: center;"><b>VOLUP</b></p> <p style="text-align: center;"><b>VOLDOWN</b></p> <p style="text-align: center;"><b>ATT/LOUD</b></p> </td> <td data-bbox="630 800 1370 947"> <p>The auto store memory operation is continued.</p> <p>The operation of the pressed key is performed.</p> </td> </tr> </tbody> </table> <p>Operating any momentary key other than above keys is invalid.</p>	Key	Description of Operations	<p style="text-align: center;"><b>ASM</b></p>	<p>The auto store memory operation is stopped, and if more than one station is found, M1 is received.</p> <p>If no station is found, the frequency at the beginning of the operation is received.</p>	<p style="text-align: center;"><b>SELECT</b></p> <p style="text-align: center;"><b>VOLUP</b></p> <p style="text-align: center;"><b>VOLDOWN</b></p> <p style="text-align: center;"><b>ATT/LOUD</b></p>	<p>The auto store memory operation is continued.</p> <p>The operation of the pressed key is performed.</p>
Key	Description of Operations						
<p style="text-align: center;"><b>ASM</b></p>	<p>The auto store memory operation is stopped, and if more than one station is found, M1 is received.</p> <p>If no station is found, the frequency at the beginning of the operation is received.</p>						
<p style="text-align: center;"><b>SELECT</b></p> <p style="text-align: center;"><b>VOLUP</b></p> <p style="text-align: center;"><b>VOLDOWN</b></p> <p style="text-align: center;"><b>ATT/LOUD</b></p>	<p>The auto store memory operation is continued.</p> <p>The operation of the pressed key is performed.</p>						
<p style="text-align: center;"><b>MONO</b></p>	<p>This key sets forced monaural mode in RADIO mode.</p> <p>It is valid only when the FM band is selected in RADIO mode.</p> <p>If this key is pressed, the "MONO" display on the LCD panel is lit thus placing the device in forced monaural mode.</p> <p>During forced monaural mode, high level is output from the "MONO" pin.</p> <p>If this key is pressed again during forced monaural mode, the "MONO" display is extinguished and the mode is canceled. In the forced monaural mode, the "STEREO" display is unlit even when a stereo signal is input.</p>						
<p style="text-align: center;"><b>PI</b></p>	<p>This is a key that sets permission for PI seek operation.</p> <p>When this key is pressed, the "PI" display lights on the LCD panel, and the PI seek permission status is entered. In the PI seek permission status, if a preset is called up, and the received PI code differs from the PI code stored in preset memory, PI seek is performed.</p> <p>When the key is pressed again while in PI seek permission status, the "PI" display is extinguished, and then even if the PI code stored in preset memory differs from the called out broadcast station PI code, no PI seek is performed.</p>						
<p style="text-align: center;"><b>NR</b></p>	<p>This is the ON/OFF key for tape noise reduction.</p> <p>It is invalid in other than TAPE mode.</p> <p>If this key is pressed, the "NR" display on the LCD panel is lit, turning on NR. While the "NR" display is lit, high level is output from the NR pin.</p> <p>If this key is pressed again while the "NR" display is lit, the "NR" display is extinguished, thus turning off NR.</p>						
<p style="text-align: center;"><b>METAL</b></p>	<p>This is the normal/metal tape switchover key.</p> <p>It is invalid in other than TAPE mode.</p> <p>If this key is pressed, the "METAL" display on the LCD panel is lit.</p> <p>While the "METAL" display is lit, high level is output from the METAL pin.</p> <p>If this key is pressed again while the "METAL" display is lit, the "METAL" display is extinguished.</p>						

Symbol	Description of Functions
<p style="text-align: center;"><b>RDS</b></p>	<p>This key selects AF operation mode.                      It is valid only when the FM band is been received.                      If this key is pressed, the "RDS" display on the LCD panel lights thus placing the device in AF operation enable mode.                      While the "RDS" display is on, when the AF operation start condition is met, AF operations performed.                      If AUTO SEEK is performed by the <b>SEEKUP</b> / <b>SEEKDOWN</b> key in this mode, it results in operation of RDS broadcasting station detection.                      If the key is pressed again while the "RDS" display is lit, the "RDS" display is extinguished, thus placing the device in the AF operation disable mode.                      If an RDS broadcasting station is being received, incorporation of RDS data is performed regardless of the ON/OFF state of the "RDS" display.</p>
<p style="text-align: center;"><b>TP/SK</b></p>	<p>This key selects traffic information interrupt operation mode.                      When this key is pressed, the "TP/SK" display on the LCD panel is lit placing the device in traffic information stand-by status.                      If both RDS TP and TA bits become 1 at this time, the device is placed in the traffic information interrupt status, thus displaying "T INFO" on the 14 segments of the LCD panel and switching the sound to RADIO mode.                      If the TP/TA bit becomes other than 1 during the traffic information interrupt, the traffic information stand-by mode is restored and the sound before the traffic information interrupt is returned.                      If the key is pressed again while the "TP/SK" display is lit, the "TP/SK" display is extinguished and the traffic information stand-by status is canceled.                      If the device is in the midst of a traffic information interrupt at this time, the traffic information interrupt is canceled and the sound before the traffic information interrupt is returned.                      While "TP/SK" remains unlit, no traffic information interrupt is accepted. The SEEK operation while the "TP/SK" display is lit is for searching traffic information stations only.</p>

Symbol	Description of Functions										
<div style="border: 1px solid black; padding: 2px; width: fit-content; margin-bottom: 5px;">ME</div>	<p>This key sets to make preset memory writable.</p> <p>When initial setting diode MESEL = 1, the key is used to write into preset memory.</p> <p>While frequency, PS or band/preset is being displayed, if the key is pressed, the "ME" display lights on the LCD panel and the memory becomes writable for 5 seconds. During this time, if a preset memory key <div style="border: 1px solid black; padding: 2px; display: inline-block;">M1</div> to <div style="border: 1px solid black; padding: 2px; display: inline-block;">M6</div> is pressed, the frequency currently being received is written into the preset memory. If the <div style="border: 1px solid black; padding: 2px; display: inline-block;">ME</div> key is being pressed and held during this time, the frequency cannot be written. When an RDS station is being received in the FM band, both the frequency and the PI code of the station are written.</p> <p>If the <div style="border: 1px solid black; padding: 2px; display: inline-block;">ME</div> key is again pressed while the "ME" display is lighted, then the memory becomes writable for another 5 seconds from the release of the key.</p> <p>If tuning is in progress, the procedure has no effect.</p> <p>Operation of each key in the ME state is as follows.</p> <table border="1" style="width: 100%; border-collapse: collapse;"> <thead> <tr> <th style="width: 20%;">Key</th> <th>Description of Operations</th> </tr> </thead> <tbody> <tr> <td style="text-align: center;"> <div style="border: 1px solid black; padding: 2px; display: inline-block;">M1</div>    <div style="border: 1px solid black; padding: 2px; display: inline-block;">M6</div> </td> <td>                     Cancel preset memory writable state.                      When the key is pressed, the frequency being received is written in the corresponding preset memory.                 </td> </tr> <tr> <td style="text-align: center;"> <div style="border: 1px solid black; padding: 2px; display: inline-block;">ME</div> </td> <td>                     Make preset memory writable for another 5 seconds after releasing the key.                 </td> </tr> <tr> <td style="text-align: center;"> <div style="border: 1px solid black; padding: 2px; display: inline-block;">SEEKUP</div>  <div style="border: 1px solid black; padding: 2px; display: inline-block;">SEEKDOWN</div>  <div style="border: 1px solid black; padding: 2px; display: inline-block;">PSCAN</div>  <div style="border: 1px solid black; padding: 2px; display: inline-block;">BAND</div>  <div style="border: 1px solid black; padding: 2px; display: inline-block;">ASM</div>  <div style="border: 1px solid black; padding: 2px; display: inline-block;">AUTO</div>  <div style="border: 1px solid black; padding: 2px; display: inline-block;">SELECT</div>  <div style="border: 1px solid black; padding: 2px; display: inline-block;">VOLUP</div>  <div style="border: 1px solid black; padding: 2px; display: inline-block;">VOLDOWN</div>  <div style="border: 1px solid black; padding: 2px; display: inline-block;">ATT/LOUD</div>  <div style="border: 1px solid black; padding: 2px; display: inline-block;">DISP</div> </td> <td>                     Cancel preset memory writable state.                      Do the function of the key pressed after the last channel.                 </td> </tr> <tr> <td style="text-align: center;"> <div style="border: 1px solid black; padding: 2px; display: inline-block;">TP/SK</div>  <div style="border: 1px solid black; padding: 2px; display: inline-block;">RDS</div>  <div style="border: 1px solid black; padding: 2px; display: inline-block;">PI</div> </td> <td> <ul style="list-style-type: none"> <li>• Upon reception of FM band The preset memory writable state is canceled and the operation of the pressed key is performed.</li> <li>• Upon reception of AM band The operation of the pressed key becomes invalid.</li> </ul> </td> </tr> </tbody> </table> <p>Momentary keys other than those given above have no effect.</p>	Key	Description of Operations	<div style="border: 1px solid black; padding: 2px; display: inline-block;">M1</div>   <div style="border: 1px solid black; padding: 2px; display: inline-block;">M6</div>	Cancel preset memory writable state. When the key is pressed, the frequency being received is written in the corresponding preset memory.	<div style="border: 1px solid black; padding: 2px; display: inline-block;">ME</div>	Make preset memory writable for another 5 seconds after releasing the key.	<div style="border: 1px solid black; padding: 2px; display: inline-block;">SEEKUP</div> <div style="border: 1px solid black; padding: 2px; display: inline-block;">SEEKDOWN</div> <div style="border: 1px solid black; padding: 2px; display: inline-block;">PSCAN</div> <div style="border: 1px solid black; padding: 2px; display: inline-block;">BAND</div> <div style="border: 1px solid black; padding: 2px; display: inline-block;">ASM</div> <div style="border: 1px solid black; padding: 2px; display: inline-block;">AUTO</div> <div style="border: 1px solid black; padding: 2px; display: inline-block;">SELECT</div> <div style="border: 1px solid black; padding: 2px; display: inline-block;">VOLUP</div> <div style="border: 1px solid black; padding: 2px; display: inline-block;">VOLDOWN</div> <div style="border: 1px solid black; padding: 2px; display: inline-block;">ATT/LOUD</div> <div style="border: 1px solid black; padding: 2px; display: inline-block;">DISP</div>	Cancel preset memory writable state. Do the function of the key pressed after the last channel.	<div style="border: 1px solid black; padding: 2px; display: inline-block;">TP/SK</div> <div style="border: 1px solid black; padding: 2px; display: inline-block;">RDS</div> <div style="border: 1px solid black; padding: 2px; display: inline-block;">PI</div>	<ul style="list-style-type: none"> <li>• Upon reception of FM band The preset memory writable state is canceled and the operation of the pressed key is performed.</li> <li>• Upon reception of AM band The operation of the pressed key becomes invalid.</li> </ul>
Key	Description of Operations										
<div style="border: 1px solid black; padding: 2px; display: inline-block;">M1</div>   <div style="border: 1px solid black; padding: 2px; display: inline-block;">M6</div>	Cancel preset memory writable state. When the key is pressed, the frequency being received is written in the corresponding preset memory.										
<div style="border: 1px solid black; padding: 2px; display: inline-block;">ME</div>	Make preset memory writable for another 5 seconds after releasing the key.										
<div style="border: 1px solid black; padding: 2px; display: inline-block;">SEEKUP</div> <div style="border: 1px solid black; padding: 2px; display: inline-block;">SEEKDOWN</div> <div style="border: 1px solid black; padding: 2px; display: inline-block;">PSCAN</div> <div style="border: 1px solid black; padding: 2px; display: inline-block;">BAND</div> <div style="border: 1px solid black; padding: 2px; display: inline-block;">ASM</div> <div style="border: 1px solid black; padding: 2px; display: inline-block;">AUTO</div> <div style="border: 1px solid black; padding: 2px; display: inline-block;">SELECT</div> <div style="border: 1px solid black; padding: 2px; display: inline-block;">VOLUP</div> <div style="border: 1px solid black; padding: 2px; display: inline-block;">VOLDOWN</div> <div style="border: 1px solid black; padding: 2px; display: inline-block;">ATT/LOUD</div> <div style="border: 1px solid black; padding: 2px; display: inline-block;">DISP</div>	Cancel preset memory writable state. Do the function of the key pressed after the last channel.										
<div style="border: 1px solid black; padding: 2px; display: inline-block;">TP/SK</div> <div style="border: 1px solid black; padding: 2px; display: inline-block;">RDS</div> <div style="border: 1px solid black; padding: 2px; display: inline-block;">PI</div>	<ul style="list-style-type: none"> <li>• Upon reception of FM band The preset memory writable state is canceled and the operation of the pressed key is performed.</li> <li>• Upon reception of AM band The operation of the pressed key becomes invalid.</li> </ul>										

Symbol	Description of Functions
<p style="text-align: center;"><b>DISP</b></p>	<p>This key switches the display and adjusts the clock in conjunction with <b>SEEKUP</b> / <b>SEEKDOWN</b></p> <p><b>(1) Display switchover function</b> Pressing the key switches the display.</p> <p><b>&lt;1&gt; Operation in RADIO mode</b> While PS is in operation, pressing the key changes the screen to frequency display. While frequency is being displayed, if the initial setting diode NOCLK = 0, pressing the key changes the screen to clock display; if NOCLK = 1 and PS code is loaded on the FM band, pressing the key changes the screen to PS display; otherwise, the key has no effect. While clock, band/preset, or electronic volume is being displayed, if PS code is loaded on the FM band, pressing the key changes the screen to PS display; otherwise, pressing the key changes the screen to frequency display. Even if PRIDISP = 0, when PS code is loaded, the frequency display changes to PS display in 5 seconds.</p> <div style="text-align: center;"> <pre> graph LR     PS["(PS)"] --&gt; Freq["Frequency"]     Freq --&gt; Clock["(Clock)"]     Clock -.-&gt; Invalid["Invalid"]     Invalid -.-&gt; PS     Invalid -.-&gt; Freq     </pre> <p>← If the screen shows the clock display, electronic volume display or band/preset display</p> </div> <p><b>&lt;2&gt; Operation in TAPE/CD mode</b> If "TAPE" or "CD" is being displayed, and initialize diode NOCLK = 0, pressing the key changes the screen to clock display; NOCLK = 1, the key has no effect. While the clock or electronic volume is being displayed, pressing the key changes the screen to "TAPE" or "CD".</p> <div style="text-align: center;"> <pre> graph LR     Tape["\"TAPE\" or \"CD\" display"] --&gt; Clock["Clock display"]     Clock -.-&gt; Invalid["Invalid"]     Invalid -.-&gt; Tape     </pre> <p>← If the screen shows the clock display or electronic volume display</p> </div>

Symbol	Description of Functions
<div style="border: 1px solid black; padding: 2px; width: fit-content; margin-bottom: 5px;">DISP</div>	<p><b>&lt;3&gt; Operation in ALARM/traffic information interrupt mode</b></p> <p>While "ALARM" is displayed, the key has no effect.</p> <p>While "T INFO" is displayed, if PS code is loaded, pressing the key changes the screen to the PS display; otherwise, pressing the key changes the screen to frequency display.</p> <p>While PS is displayed, pressing the key changes the screen to the frequency display.</p> <p>While the frequency is displayed, if the initialize diode NOCLK = 0, pressing the key changes the screen to the clock display; NOCLK = 1, pressing the key changes the screen to the "T INFO" display.</p> <p>While the clock or electronic volume is displayed (volume, bass, treble, balance, fader), pressing the key changes the screen to "T INFO".</p> <p>Even if the initialize diode PRIDISP = 0, the screen changes from frequency to "T INFO" in 5 seconds.</p> <div style="text-align: center; margin: 10px 0;"> <pre> graph LR     A["T INFO" display] --&gt; B["(PS)"]     B --&gt; C["Frequency"]     C --&gt; D["(Clock)"]     D -.-&gt; In about 5 seconds  A     </pre> </div> <p>If initialize diode PRIDISP = 1, the screen changes to the current highest priority screen in about 5 seconds.</p> <p>If initialize diode NOCLK = 1 and PS code is loaded in FM band, pressing the key changes the screen to the PS display.</p> <p>If initialize diode NOCLK = 0, pressing the key changes the screen to the clock display.</p> <p>While tuning is in progress, the key has no effect.</p> <p><b>(2) Clock adjustment function</b></p> <p>The key is used in conjunction with the <span style="border: 1px solid black; padding: 2px;">SEEKUP</span> / <span style="border: 1px solid black; padding: 2px;">SEEKDOWN</span> keys to adjust the clock.</p> <p>For details, refer to description of the <span style="border: 1px solid black; padding: 2px;">SEEKUP</span> / <span style="border: 1px solid black; padding: 2px;">SEEKDOWN</span> keys.</p>



Symbol	Description of Functions								
<div style="border: 1px solid black; padding: 2px; margin-bottom: 10px; text-align: center;"> <b>SEEKUP (MANU.UP)</b> </div> <div style="border: 1px solid black; padding: 2px; text-align: center;"> <b>SEEKDOWN (MANU.DOWN)</b> </div>	<p>While the frequency is being displayed, the key operates as the auto seek/manual seek operation function key for the receiving frequency. While the clock is being displayed, the key operates as the clock adjustment key in conjunction with the <span style="border: 1px solid black; padding: 0 5px;">DISP</span> key.</p> <p><b>(1) Auto seek operation</b>            While the "AUTO" display is lit, auto seek is in operation.            Auto seek operation is divided into three modes by the setting the current RDS and traffic information stand-by.</p> <p><b>&lt;1&gt; Normal seek mode</b>            Pressing the key starts auto seek from the current frequency upwards (<span style="border: 1px solid black; padding: 0 5px;">SEEKUP</span> key) or downwards (<span style="border: 1px solid black; padding: 0 5px;">SEEKDOWN</span> key) in single steps (100 kHz per step in the FM band) and lights the "AUTO" display.            The presence/absence of a broadcasting station is detected at each frequency. If a station is detected, the frequency is retained. For a seek operation on LW, even if a broadcasting station is detected, if the frequency is not multiple of 9, the seek operation continues.</p> <p><b>&lt;2&gt; RDS seek mode</b>            While the "RDS" display is lit in the FM band, pressing the key changes the mode to RDS seek mode.            RDS seek mode operation is the same as normal seek mode operation until a broadcasting station is detected. However, when a station is found, RDS seek mode operation begins RDS signal synchronous detection, checks the synchronous status after 200 ms, and if an RDS station is detected (synchronous RDS signal is detected), the frequency is retained.            If an RDS station is not detected, the seek operation continues.</p> <p><b>&lt;3&gt; TP/SK seek mode</b>            While the "TP/SK" display is lit, pressing the key in the FM band changes the mode to TP/SK mode.            TP/SK seek mode operation is the same as RDS seek mode operation until an RDS broadcasting station is detected. However, when a station is found, TP/SK seek mode begins TP/SK signal synchronous detection, checks the RDS data TP bit after 300 ms, and if TP is detected, the frequency is retained. If TP is not detected, the seek operation continues.            If an RDS station is not detected, the <math>\overline{SK}</math> pin is checked after 300 ms, and if an <math>\overline{SK}</math> signal is detected, the frequency is retained.            If <math>\overline{SK}</math> is not detected, the seek operation continues.</p> <p>key operation during auto seek operation is as follows.</p> <table border="1" data-bbox="488 1455 1456 1612" style="width: 100%; border-collapse: collapse;"> <thead> <tr> <th style="width: 30%;">Key</th> <th>Description of Operations</th> </tr> </thead> <tbody> <tr> <td style="text-align: center;"><span style="border: 1px solid black; padding: 0 5px;">M1</span></td> <td>The seek operation is stopped.</td> </tr> <tr> <td style="text-align: center;"> </td> <td>Call up the content of the preset memory for the pressed key.</td> </tr> <tr> <td style="text-align: center;"><span style="border: 1px solid black; padding: 0 5px;">M6</span></td> <td>Writing is inhibited.</td> </tr> </tbody> </table>	Key	Description of Operations	<span style="border: 1px solid black; padding: 0 5px;">M1</span>	The seek operation is stopped.		Call up the content of the preset memory for the pressed key.	<span style="border: 1px solid black; padding: 0 5px;">M6</span>	Writing is inhibited.
Key	Description of Operations								
<span style="border: 1px solid black; padding: 0 5px;">M1</span>	The seek operation is stopped.								
	Call up the content of the preset memory for the pressed key.								
<span style="border: 1px solid black; padding: 0 5px;">M6</span>	Writing is inhibited.								

Symbol	Description of Functions										
<p><b>SEEKUP (MANU.UP)</b></p>											
<p><b>SEEKDOWN (MANU.DOWN)</b></p>	<table border="1"> <thead> <tr> <th data-bbox="402 268 626 310">Key</th> <th data-bbox="626 268 1369 310">Description of Operations</th> </tr> </thead> <tbody> <tr> <td data-bbox="402 310 626 594"> <p><b>SEEKUP</b> <b>SEEKDOWN</b></p> </td> <td data-bbox="626 310 1369 594"> <ul style="list-style-type: none"> <li>• While seek up is in progress, pressing the <b>SEEKUP</b> key, and while seek down is in progress, pressing the <b>SEEKDOWN</b> key stops the seek operation and retains the frequency at that time.</li> <li>• While seek up is in progress, pressing the <b>SEEKDOWN</b> key, and while seek down is in progress, pressing the <b>SEEKUP</b> key changes the operation. (e.g. Press the <b>SEEKUP</b> key changes to seek up.)</li> </ul> </td> </tr> <tr> <td data-bbox="402 594 626 737"> <p><b>PSCAN</b> <b>BAND</b> <b>ASM</b> <b>AUTO</b></p> </td> <td data-bbox="626 594 1369 737"> <p>The seek operation is stopped. The operation of the pressed key is performed.</p> </td> </tr> <tr> <td data-bbox="402 737 626 879"> <p><b>SELECT</b> <b>VOLUP</b> <b>VOLDOWN</b> <b>ATT/LOUD</b></p> </td> <td data-bbox="626 737 1369 879"> <p>The seek operation is continued. The operation of the pressed key is performed.</p> </td> </tr> <tr> <td data-bbox="402 879 626 1083"> <p><b>TP/SK</b> <b>RDS</b></p> </td> <td data-bbox="626 879 1369 1083"> <ul style="list-style-type: none"> <li>• Upon reception of FM band The seek operation is continued. The operation of the pressed key is started.</li> <li>• Upon reception of AM band It becomes invalid. The seek operation is continued.</li> </ul> </td> </tr> </tbody> </table> <p>Momentary keys other than the above have no effect.</p> <p><b>(2) Manual seek operation</b> Pressing the key updates the frequency from the frequency when the key was pressed in the upward direction (<b>SEEKUP</b> key) or downward direction (<b>SEEKDOWN</b> key) by 1 step. Pressing and holding the key for more than 500 ms updates the frequency every 40 ms until the key is released. While receiving an RDS station, pressing the key clears PI code settings. While a manual seek operation is in progress, pressing and holding the key renders all other keys ineffective.</p> <p><b>(3) Clock adjustment operation</b> While the clock is being displayed, pressing the key and the <b>DISP</b> key together adjusts the hour (<b>SEEKUP</b> key) and minute (<b>SEEKDOWN</b> key).</p> <p><b>&lt;1&gt; Adjusting the hour</b> Pressing the <b>SEEKDOWN</b> key once adds an hour; holding the key down for more than 0.5 seconds adds an hour every 200 ms. The hour adjustment operation affects neither the minute digit nor count value.</p>	Key	Description of Operations	<p><b>SEEKUP</b> <b>SEEKDOWN</b></p>	<ul style="list-style-type: none"> <li>• While seek up is in progress, pressing the <b>SEEKUP</b> key, and while seek down is in progress, pressing the <b>SEEKDOWN</b> key stops the seek operation and retains the frequency at that time.</li> <li>• While seek up is in progress, pressing the <b>SEEKDOWN</b> key, and while seek down is in progress, pressing the <b>SEEKUP</b> key changes the operation. (e.g. Press the <b>SEEKUP</b> key changes to seek up.)</li> </ul>	<p><b>PSCAN</b> <b>BAND</b> <b>ASM</b> <b>AUTO</b></p>	<p>The seek operation is stopped. The operation of the pressed key is performed.</p>	<p><b>SELECT</b> <b>VOLUP</b> <b>VOLDOWN</b> <b>ATT/LOUD</b></p>	<p>The seek operation is continued. The operation of the pressed key is performed.</p>	<p><b>TP/SK</b> <b>RDS</b></p>	<ul style="list-style-type: none"> <li>• Upon reception of FM band The seek operation is continued. The operation of the pressed key is started.</li> <li>• Upon reception of AM band It becomes invalid. The seek operation is continued.</li> </ul>
Key	Description of Operations										
<p><b>SEEKUP</b> <b>SEEKDOWN</b></p>	<ul style="list-style-type: none"> <li>• While seek up is in progress, pressing the <b>SEEKUP</b> key, and while seek down is in progress, pressing the <b>SEEKDOWN</b> key stops the seek operation and retains the frequency at that time.</li> <li>• While seek up is in progress, pressing the <b>SEEKDOWN</b> key, and while seek down is in progress, pressing the <b>SEEKUP</b> key changes the operation. (e.g. Press the <b>SEEKUP</b> key changes to seek up.)</li> </ul>										
<p><b>PSCAN</b> <b>BAND</b> <b>ASM</b> <b>AUTO</b></p>	<p>The seek operation is stopped. The operation of the pressed key is performed.</p>										
<p><b>SELECT</b> <b>VOLUP</b> <b>VOLDOWN</b> <b>ATT/LOUD</b></p>	<p>The seek operation is continued. The operation of the pressed key is performed.</p>										
<p><b>TP/SK</b> <b>RDS</b></p>	<ul style="list-style-type: none"> <li>• Upon reception of FM band The seek operation is continued. The operation of the pressed key is started.</li> <li>• Upon reception of AM band It becomes invalid. The seek operation is continued.</li> </ul>										

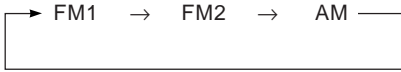
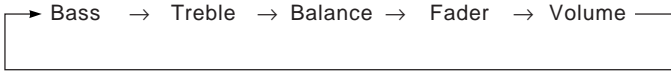
Symbol	Description of Functions
<p><b>SEEKUP (MANU.UP)</b></p> <p><b>SEEKDOWN (MANU.DOWN)</b></p>	<p><b>&lt;2&gt; Adjusting the minute</b>            Pressing the <b>SEEKUP</b> key once adds a minute; holding the key down for more than 0.5 seconds adds a minute every 100 ms. The minute adjustment operation does not affect the hour.            Whenever the minute is adjusted, the value of the second counter is reset.</p>
<p><b>BAND</b></p>	<p>This key switches the radio band.            While the sound is set to radio mode, pressing the key switches the band as follows.</p> <div style="text-align: center;">  </div> <p>Every time the band is switched, band/preset displays for 5 seconds.</p>
<p><b>AUTO</b></p>	<p>This key switches auto seek/manual seek.            While the "AUTO" display on the LCD panel is not lighted, pressing the key lights the "AUTO" display. Subsequently pressing the <b>SEEKUP</b> / <b>SEEKDOWN</b> key operates auto seek up/down.            While the "AUTO" display on the LCD panel is lighted, pressing the key turns off the display. Subsequently pressing the <b>SEEKUP</b> / <b>SEEKDOWN</b> key operates manual seek up/down. If the mode is other than radio mode, the key has no effect.</p>
<p><b>ATT/LOUD</b></p>	<p>This key sets attenuator/loudness operation.            Pressing the key and releasing it within 2 seconds turns on the attenuator and lights the "ATT" display on LCD panel.            While "ATT" is displayed, pressing the key again for less than about 2 seconds switches off the "ATT" display and turn off attenuator.            Pressing the key for more than 2 seconds turns on loudness and switches on the "LOUD" display on the LCD panel.            While "LOUD" is displayed, pressing the key again for more than about 2 seconds switches off the "LOUD" display and turns off loudness.</p>
<p><b>SELECT</b></p>	<p>The key selects the electronic volume adjustment function.            Pressing the key switches the display on the LCD panel to the electronic volume display. Pressing it again switches the adjustment function as follows.</p> <div style="text-align: center;">  </div> <p>While the electronic volume is displayed, you press the <b>VOLUP</b>, <b>VOLDOWN</b> keys for each adjustment function.            Regarding the electronic volume displays, even if the initial setting diode PRIDISP = 1, releasing any electronic volume adjustment key (<b>SELECT</b>, <b>VOLUP</b>, <b>VOLDOWN</b>) changes the screen to the highest priority display in about 5 seconds.</p>
<p><b>VOLUP</b></p> <p><b>VOLDOWN</b></p>	<p>This key adjusts any electronic volume function.            When the display on the LCD panel is other than electronic volume, pressing the key displays electronic volume and pressing <b>VOLUP</b> or <b>VOLDOWN</b> increases or decreases the sound volume.            While the electronic volume is displayed on the LCD panel, pressing the key adjusts the function currently selected (bass, treble, balance, fader, or volume).</p>

3. MODE TRANSITIONS

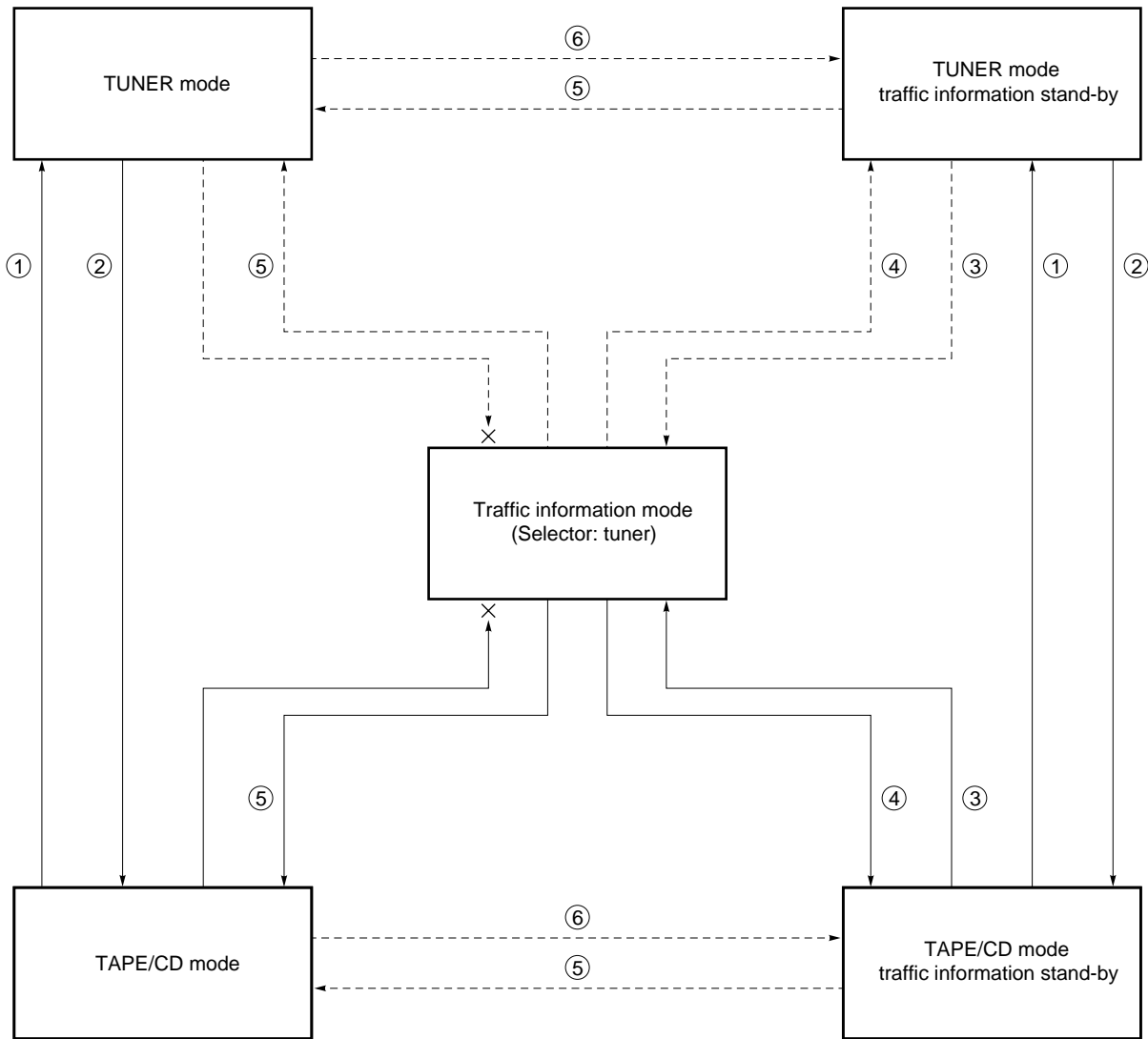

—— : Actual mode (MODE pin output, MUTE, etc.) changes.

----- : Actual mode does not change.

x ← : This mode cannot be changed.

① : TAPE pin = low level ; and CD mode is OFF.

② : TAPE pin = high level ; or CD mode is ON.

③ : TA or DK ON

④ : TA or DK OFF

⑤ : TP/SK mode OFF

⑥ : TP/SK mode ON

**4. DATA OUTPUT TO LCD CONTROLLER/DRIVER (μPD16431A)**

The μPD17012GF-055 uses the μPD16431A for LCD display and key sensing.

The μPD17012GF-055 transfers initialization data to the μPD16431A about 480 to 500 ms after the LCDPWR pin (pin 48) changes from low level to high level.

The pin configurations of the μPD17012GF-055 and the μPD16431A are shown below.

**Figure 4-1. μPD16431A Pin Configuration**

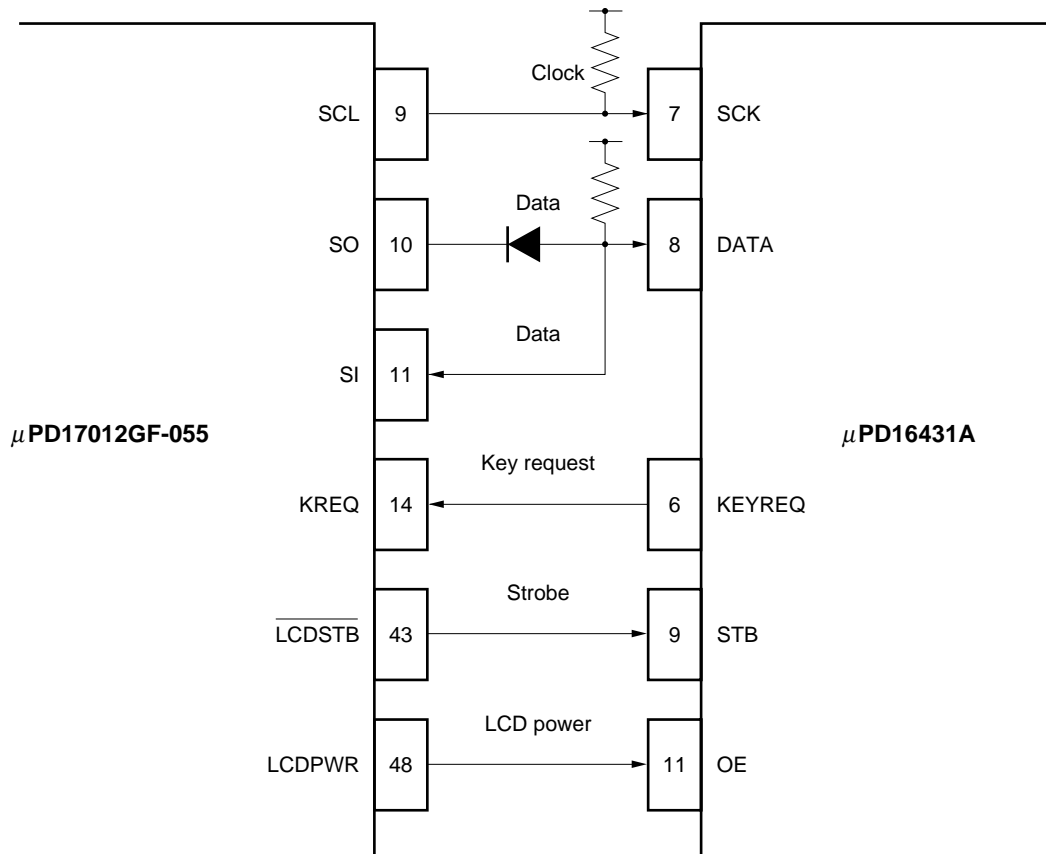

4.1 Data Input/Output Timing

(1) Initialization data output

The initialization data output to the μPD16431A is shown in Figure 4-2.

Figure 4-2. Initialization Data Output

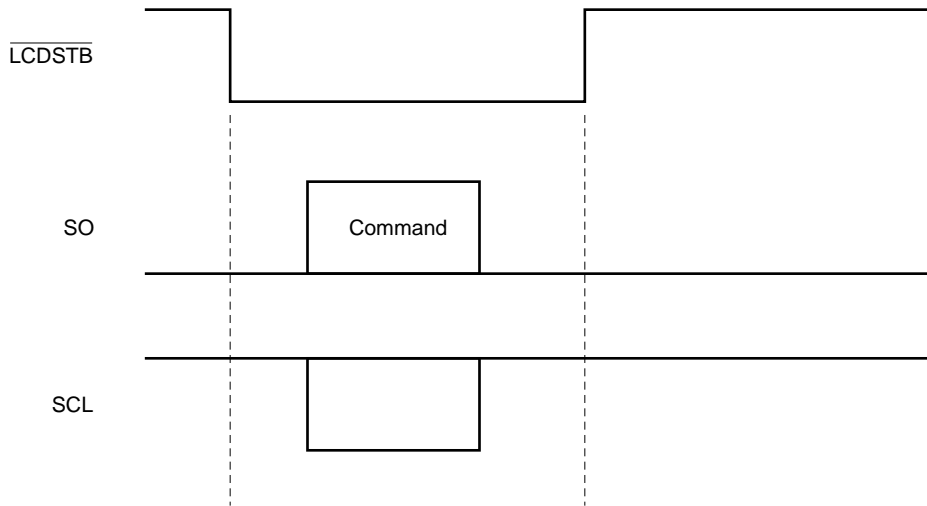

Command: 00000000 (Initialization command)

1/4 duties, ( $f_{osc}/128$ ) $\times$ n, internal driving voltage, master, and normal operation are initialized.

(2) Display data output

The display data output to the μPD16431A is shown in Figure 4-3.

Figure 4-3. Display Data Output

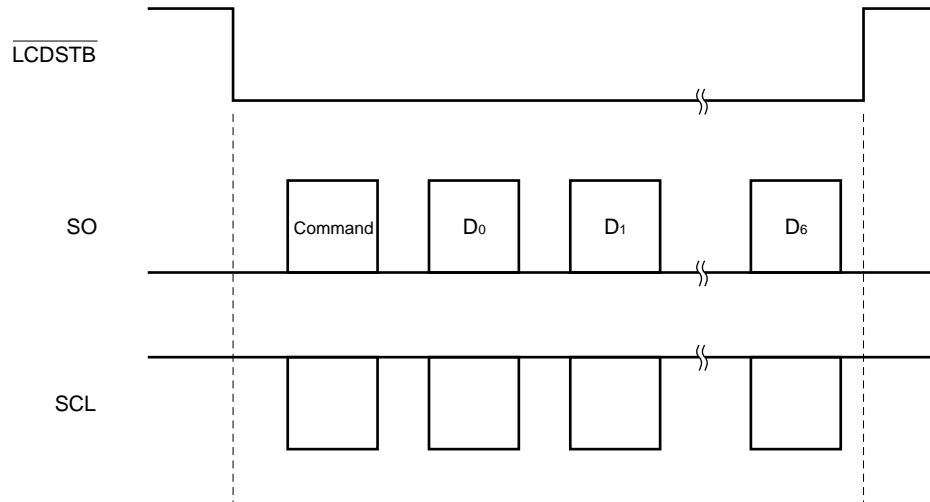

- Command : 10000100 (Status command (in COM0 output))
- : 10001100 (Status command (in COM1 output))
- : 10010100 (Status command (in COM2 output))
- : 10011100 (Status command (in COM3 output))
- D0-D6    : 00000000 (Display data)
- |
- 11111111

The display output above is repeated four times by approx. 10 ms and the display data is transmitted. At this time, the status commands COM0 to COM3 are transmitted.

(3) Key data input/output

The key data input/output to μPD16431A are shown in Figure 4-4.

Figure 4-4. Key Data Input/Output

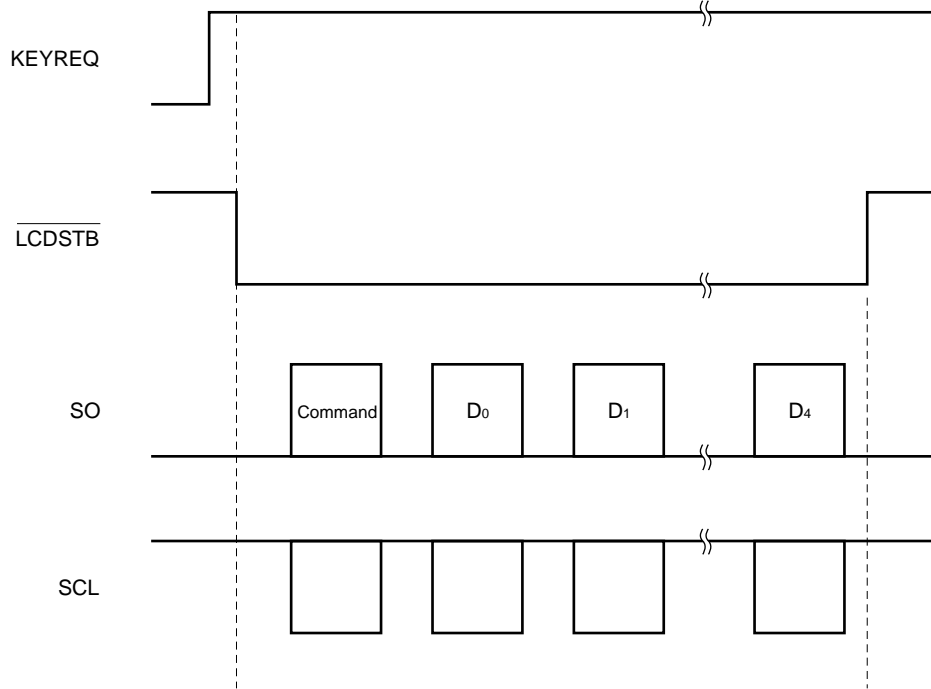

Command : 10000101 (Status command (Key data read))  
 D<sub>0</sub>-D<sub>4</sub> : 00000000 (Key data)  
 |  
 11111111







### 5.2.2 PS (Program Service Name)

This data is used for the PS display.

The PS display is made once when the same PS data is input two or more times.

The PS display appears about 5 seconds after the tuning operation is completed. If the PS data cannot be received during about 5 seconds, the PS display appears when the PS data is eventually received.

Once PS data has been received, if the display is changed by the  key or the TP/SK mode ON/OFF change is performed even if no PS data can be received thereafter, the last PS data is stored, and 3 seconds after displaying frequency, the stored PS data is displayed.

### 5.2.3 PTY (Program Type)

Used for alarm identification. When the alarm is received, the device is switched over to RADIO mode if in TAPE/CD mode.

At this time, the LCD panel displays "AL ARM".

### 5.2.4 AF (Alternative Frequency)

Used as a switchover frequency list.

#### (1) AF list input

The AF function can be used for both METHOD A and METHOD B. Up to 25 lists can be input. If AF's header block is received, the AF pointer is reset to the front and the lists are stored in the order of their transmission. If more than 25 AF lists are sent, data is overwritten starting from the top of the lists. If, in METHOD B, blocks for the same frequency arrive one after another, they are linked together to form a single AF list. Even when lists are sent in pairs of a descending sequence, all the AF lists are input.

The method of input for AF lists is shown in Figure 5-3 Flow of AF List Input.

Figure 5-3. Flow of AF List Input (1/3)

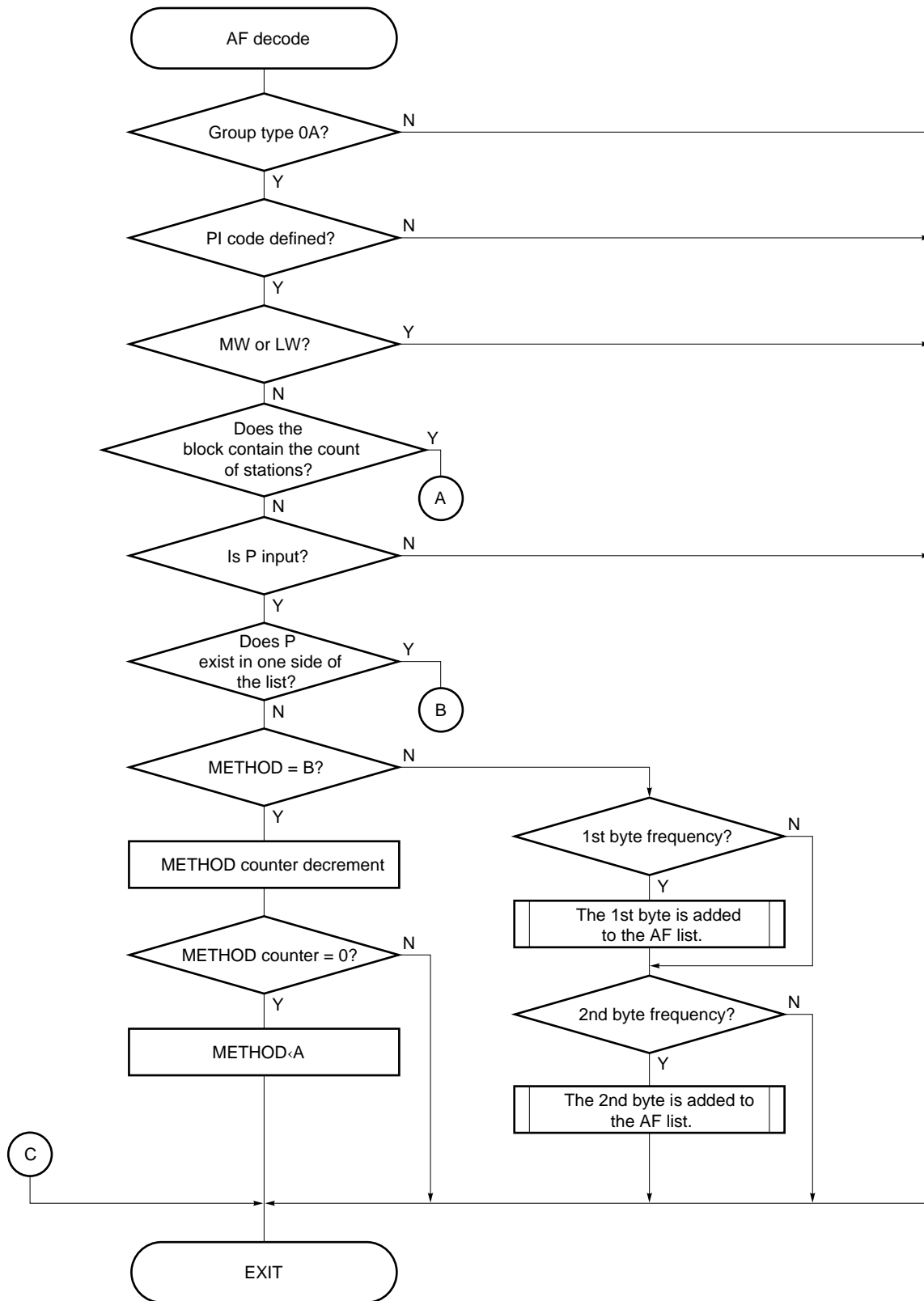

Figure 5-3. Flow of AF List Input (2/3)

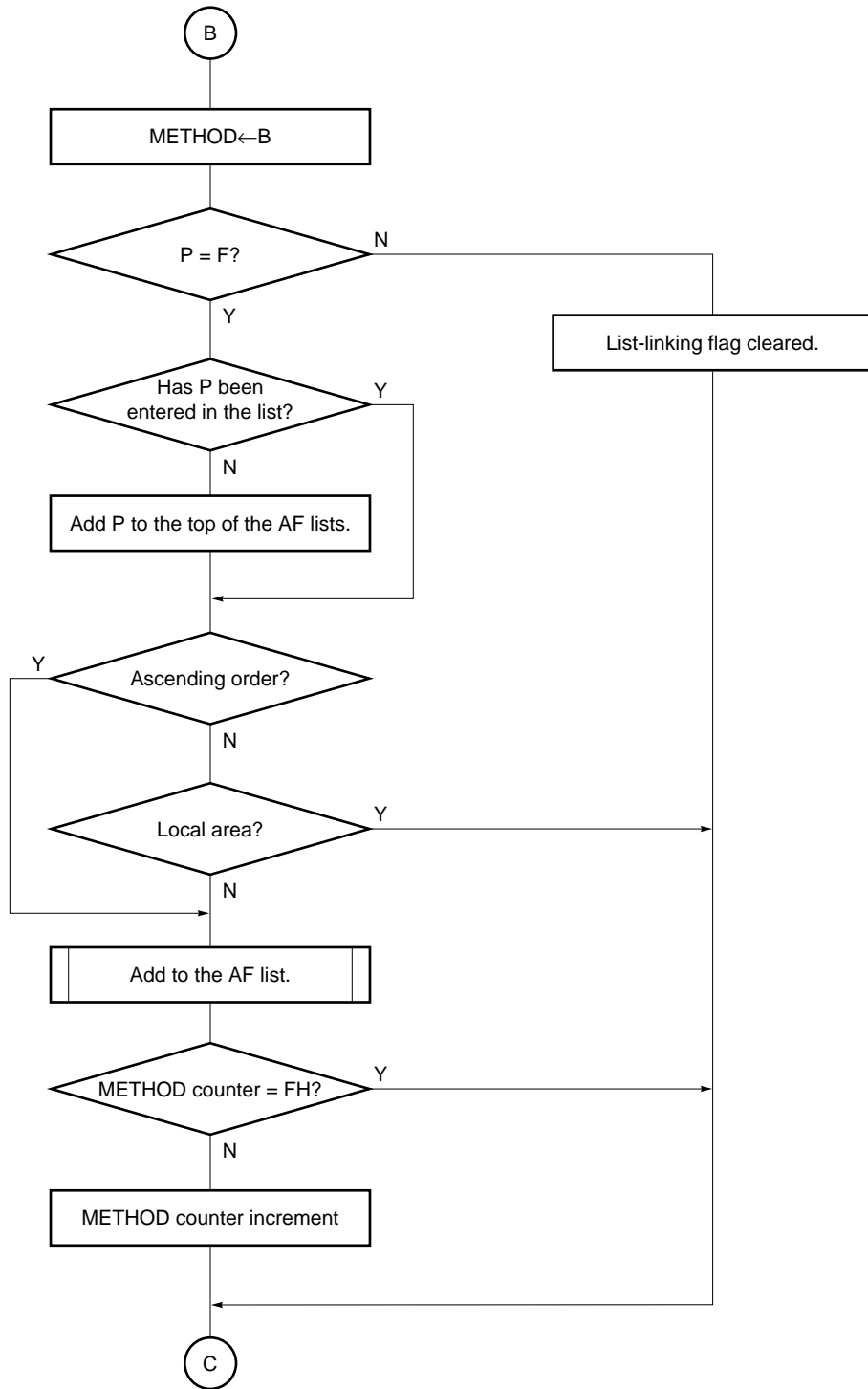
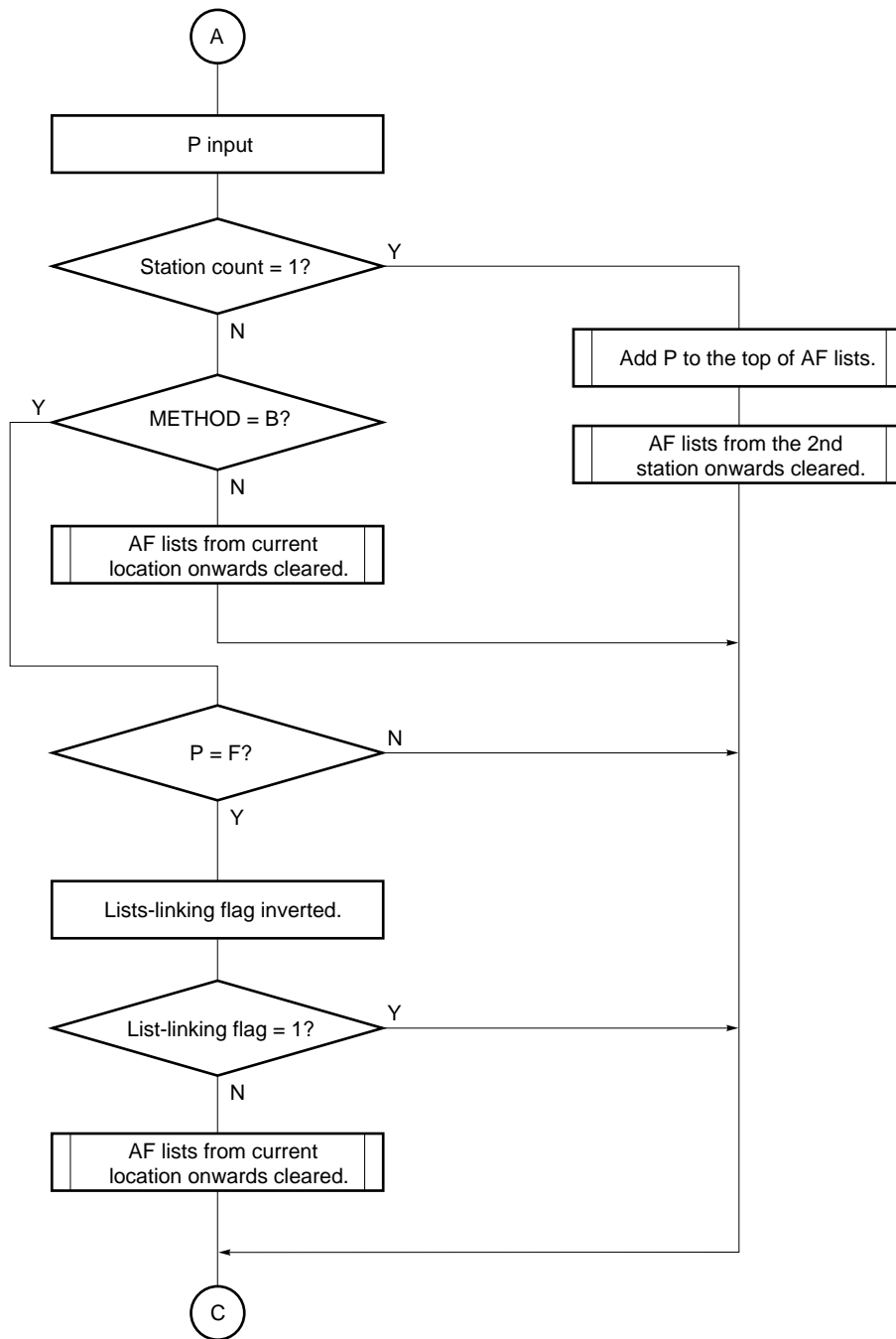

Figure 5-3. Flow of AF List Input (3/3)



P : Frequency entered in blocks containing the station count  
 F : Tuning frequency

**(2) AF check**

Data of the AF operation memory is used for AF checking. One station is checked at a time.

**① AF check start condition:**

The electric field strength of the broadcast being received is divided into the following three stages (the numeric values are those when the read A/D values are 0-3FH) by the voltage which is input from SD pin.

$$L < 0CH < M \leq 20H \leq H$$

SD Level	Description of Operations
H	AF check not started.
M	AF check started on a station every 5 seconds.
L	All the AFs at the time checked at once.

**② AF check stop condition:**

AF checking is stopped when the SD level of the AF-checked broadcast is higher than that of the broadcast originally being listened to, and the PI of the broadcast at the check destination has satisfied the STOP condition.

Conditions for broadcast (PI) capable of AF switchover are as follows:

- Broadcast whose 16 bits are completely identical, including the PI code and the area cover code of the broadcast being currently received.
- Broadcast whose area cover code is '4' to 'F' when the PI code and the area cover code of the broadcast being currently received is '1' to '3', and whose remaining 12 bits are identical.
- Broadcast whose area cover code is '1' to '3' when the PI code and the area cover code of the broadcast being currently received is '4' to 'F', and whose remaining 12 bits are identical.

**③ AF check for calling when CE low level has been switched over to high level or when the last station is an FM RDS station:**

AF checking is performed for calling when the CE low level has been switched over to low level or when the last station is an FM RDS station.

At this time, the AF data of the last channel memory is moved to the AF operation memory, and immediately all the AFs are checked. The broadcasting station whose PI stored in the preset memory has satisfied the STOP condition and whose SD level is the highest is selected for reception. This AF checking is performed during MUTE output.

If no station satisfies the STOP condition as a result of checking the broadcast stations of the preset frequency and all their AF, the SEEK operation is performed upwards from the preset frequency to detect the broadcasting station which satisfies the STOP condition.

If a broadcasting station which satisfies the STOP condition appears, the SEEK operation is halted to receive the relevant broadcasting station (PI search). Even if the SEEK operation is carried out across the entire width of reception band, if a broadcasting station which satisfies the STOP condition cannot be found, the SEEK operation is halted to receive the originally set frequency.

### 5.2.5 TP (Traffic Program Identification), TA (Traffic Announcement Identification)

These are used for traffic information station identification and traffic information announcement identification. Depending on the TP and TA statuses of the current receiving station, the methods of identifying a traffic information station are as follows:

- If TP = 1,  
Recognized as the traffic information station.

TP and TA are decoded by inputting the same data at least twice after the tuning operation is ended. If 1 is input as the TP or TA data, the TP or TA counter is incremented up to 4 counts. If 0 is input, the counter is decremented; and when the counter becomes 0, it is determined that there is no TP or TA.

The method of identifying the traffic information announcement is as follows.

- If it results that TA=1 when TP=1, the traffic information is recognized as being broadcast.

The methods of switching over to the traffic information are as follows:

- If TA = 1,  
If the device is in TAPE/CD mode, it is switched over to RADIO mode.
- If TA = 0,  
Returns to the original mode.



## 6. MUTE TIMING

### 6.1 Tuner Operation

The operation of the tuner function and the output of the  $\overline{\text{MUTE}}$  pin are explained in the following order.

- (1) Preset memory reading (refer to **6.1.1 Preset memory reading**)
- (2) Preset scan (refer to **6.1.2 Preset scan**)
- (3) Preset memory writing (refer to **6.1.3 Preset memory writing**)
- (4) Seek up/down (refer to **6.1.4 Seek up/down**)
- (5) Manual up/down (refer to **6.1.5 Manual up/down**)
- (6) Auto store memory (refer to **6.1.6 Auto store memory**)
- (7) AF switchover (refer to **6.1.7 AF switchover**)

#### 6.1.1 Preset memory reading

Reading in the preset memory is performed by pressing key **M1** to **M6** for less than 2 seconds when initialize diode MESEL = 0 in TUNER mode, or by pressing these keys in modes other than preset memory write enable mode when MESEL = 1.

The timing chart showing the preset memory reading operation is shown below.

PI seek is performed if the broadcasting station being read is an FM RDS station.

**Figure 6-1. Timing Chart in Preset Memory Read (1/3)**  
**(When the Broadcasting Station Being Read Is Not RDS Station)**

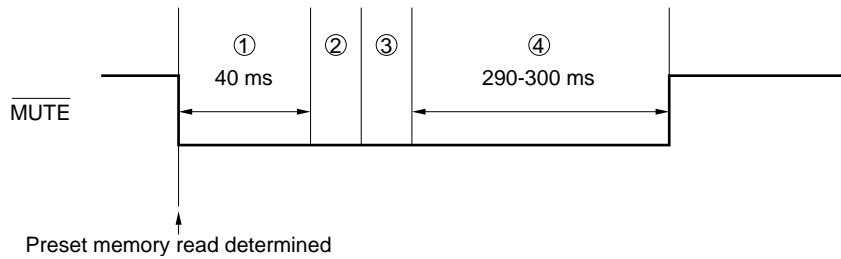

- ① MUTE first-out and beep output
- ② Frequency division ratio setting
- ③ PLL lock wait
- ④ MUTE last-out output

**Figure 6-1. Timing Chart in Preset Memory Read (2/3)**  
**(When the Broadcasting Station Being Read Is RDS Station <1> )**

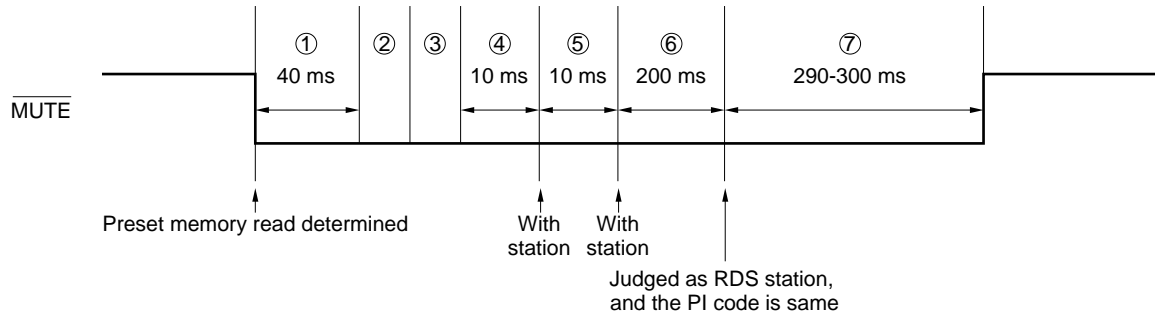

- ① MUTE first-out and beep output
- ② Frequency division ratio setting
- ③ PLL lock wait
- ④ SD stability wait (1)
- ⑤ SD stability wait (2)
- ⑥ RDS station judgment wait
- ⑦ MUTE last-out output

Figure 6-1. Timing Chart in Preset Memory Read (3/3)  
 (When the Broadcasting Station Being Read Is RDS Station <2> )

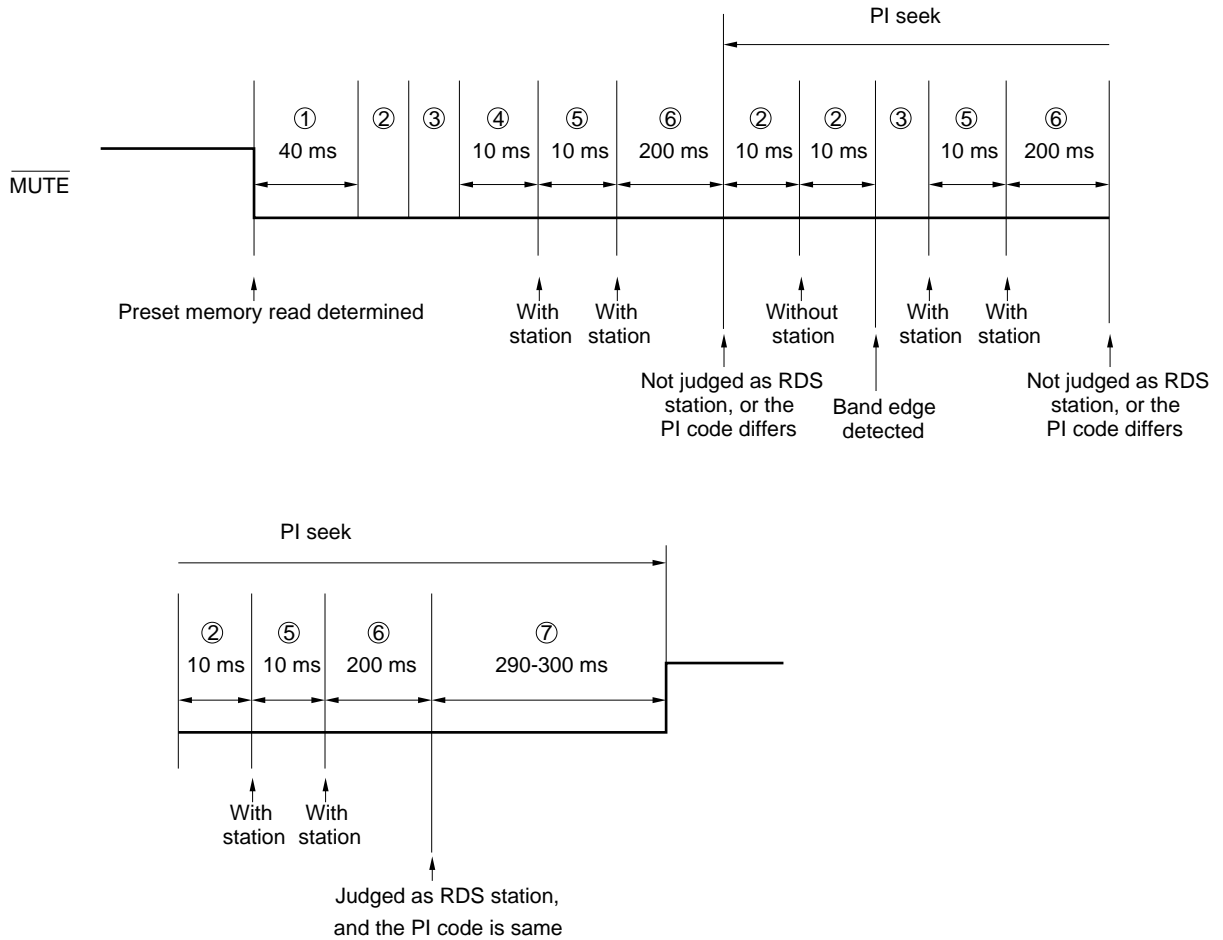

- ① MUTE first-out and beep output
- ② Frequency division ratio setting
- ③ PLL lock wait
- ④ SD stability wait (1)
- ⑤ SD stability wait (2)
- ⑥ RDS station judgment wait
- ⑦ MUTE last-out output

**6.1.2 Preset scan**

The preset scan operation is started by pressing the **PSCAN** key in TUNER mode. The timing chart showing the preset scan operation is shown below.

**Figure 6-2. Timing Chart in Preset Scanning**

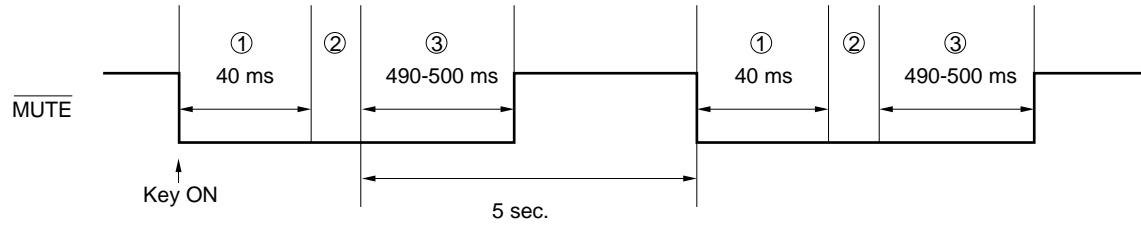

- ① MUTE first-out and beep output
- ② Frequency division ratio setting
- ③ MUTE last-out output

**6.1.3 Preset memory writing**

Writing in the preset memory is performed by pressing key **M1** to **M6** for 2 seconds or longer when initialize diode MESEL = 0 in TUNER mode, or by pressing these keys in the preset memory write enable mode when MESEL = 1.

The timing chart showing the preset memory writing operation is shown below.

If the station being received is an FM RDS station, PI code of the station is written simultaneously.

**Figure 6-3. Timing Chart in Preset Memory Write (1/2)  
(at MESEL = 0)**

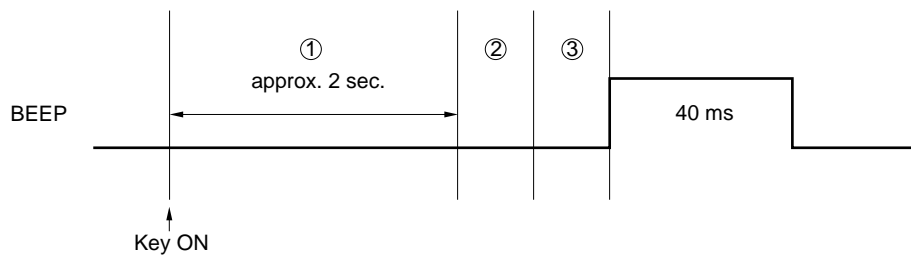

- ① Preset memory read/write judgment wait
- ② Preset memory write
- ③ PI code write (upon reception of the FM RDS station)

Figure 6-3. Timing Chart in Preset Memory Write (2/2)  
(at MESEL = 1)

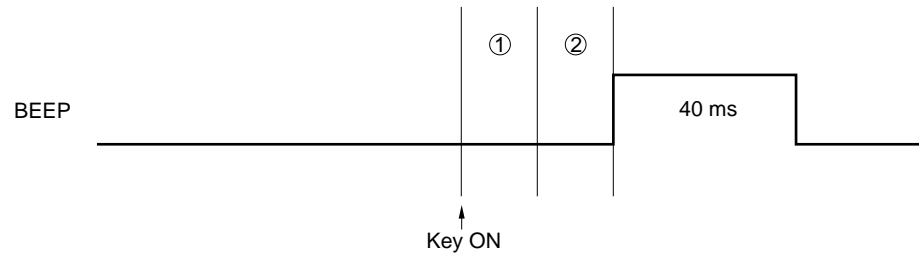

- ① Preset memory write
- ② PI code write (upon reception of the FM RDS station)

6.1.4 Seek up/down

The operation is started by pressing **SEEKUP** / **SEEKDOWN** when the device is in TUNER mode but other than in SHIFT mode.

The broadcasting station detection operation judges the IF count if the SD level and initialize diodes (AM SD/IF, FM SD/IF) are ON and terminates the SEEK operation if the condition for “with broadcasting station” is satisfied twice at the interval of 10 ms. In RDS mode and TP/SK mode, after the condition above has been satisfied, the operations of detecting the RDS broadcasting station and the traffic information station are performed according to the timing chart below.

Figure 6-4. Timing Chart in Seek Up/Down (1/3)  
(Normal Mode)

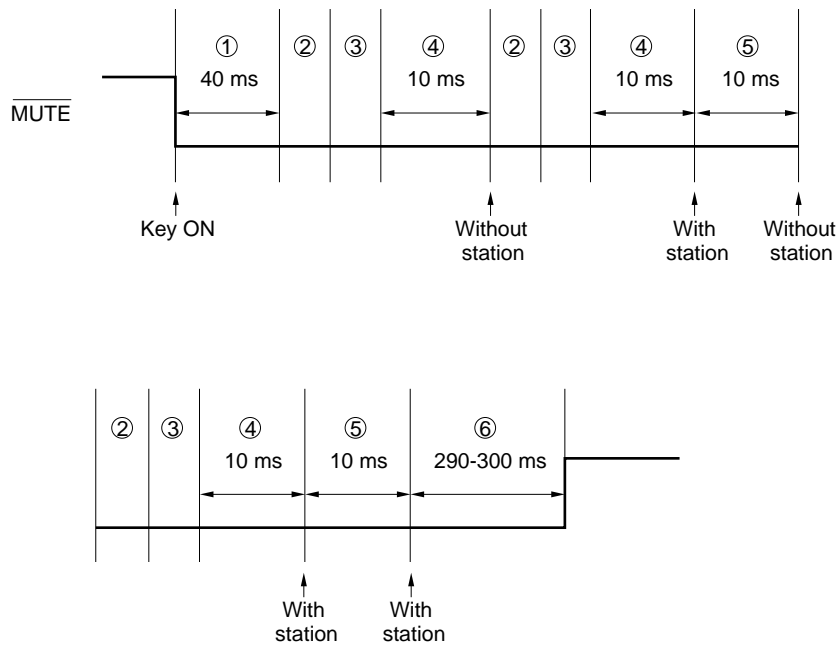

- ① MUTE first-out and beep output
- ② Frequency division ratio setting
- ③ PLL lock wait
- ④ SD stability wait (1)
- ⑤ SD stability wait (2)
- ⑥ MUTE last-out output (490-500 ms in band edge detection)

Figure 6-4. Timing Chart in Seek Up/Down (2/3)  
(RDS Mode)

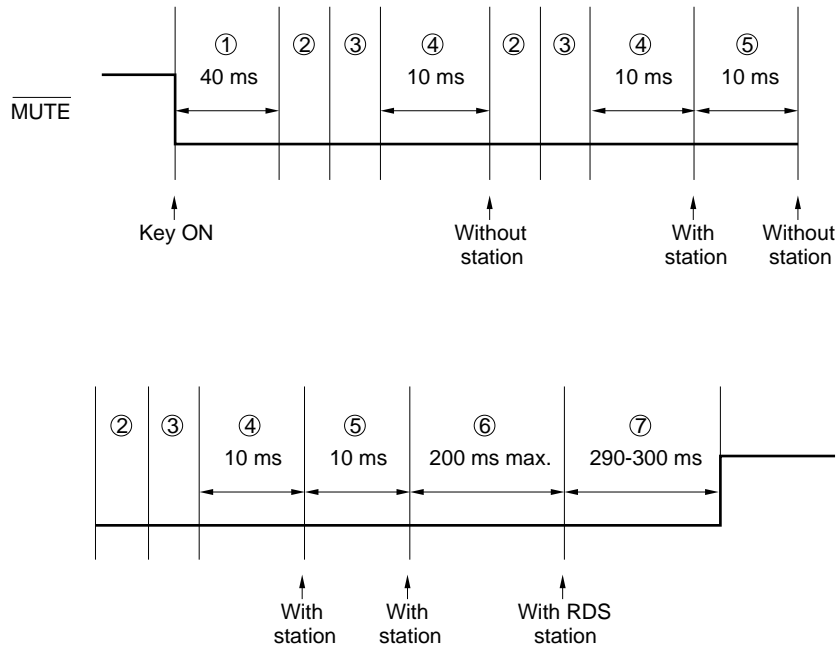

- ① MUTE first-out and beep output
- ② Frequency division ratio setting
- ③ PLL lock wait
- ④ SD stability wait (1)
- ⑤ SD stability wait (2)
- ⑥ RDS station detection wait
- ⑦ MUTE last-out output (490-500 ms in band edge detection)

Figure 6-4. Timing Chart in Seek Up/Down (3/3)  
(TP/SK Mode)

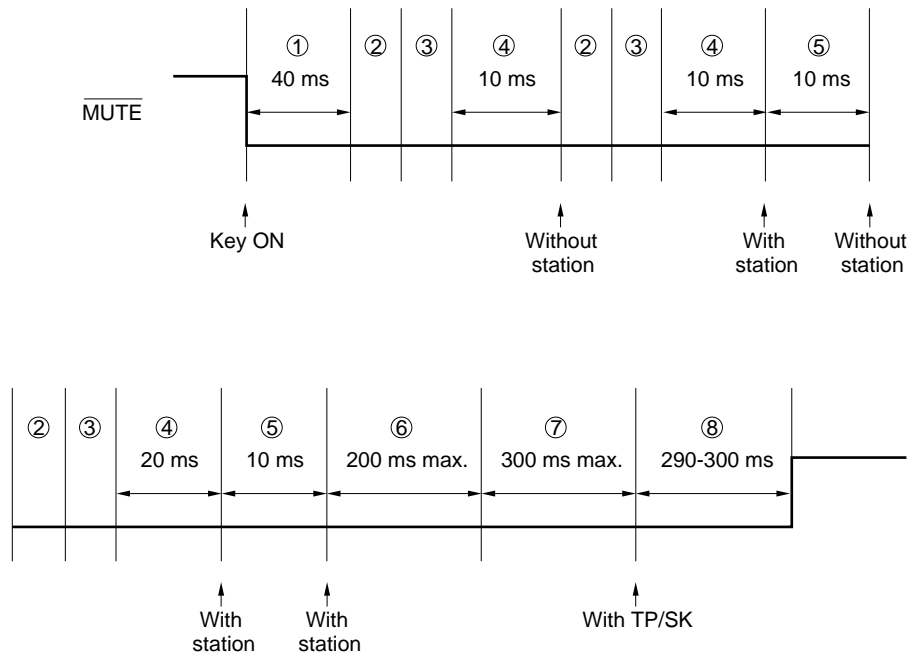

- ① MUTE first-out and beep output
- ② Frequency division ratio setting
- ③ PLL lock wait
- ④ SD stability wait (1)
- ⑤ SD stability wait (2)
- ⑥ RDS station detection wait
- ⑦ Traffic information station identification (TP/SK) wait
- ⑧ MUTE last-out output (490-500 ms in band edge detection)



**6.1.5 Manual up/down**

The operation is started by pressing **SEEKUP** / **SEEKDOWN** when the device is in TUNER mode and in SHIFT mode.

The timing chart below shows the manual operation.

**Figure 6-5. Timing Chart in Manual Operation (1/2)  
(with key released within 0.5 second)**

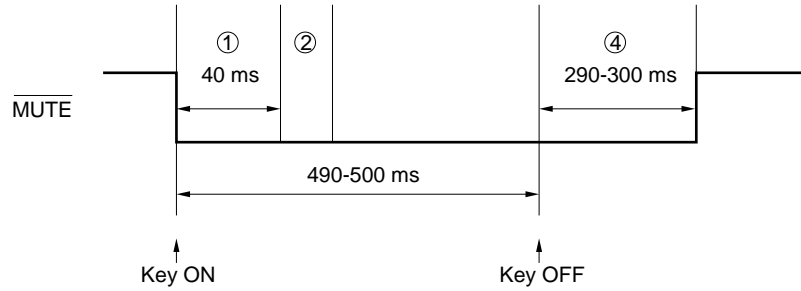

**Figure 6-5. Timing Chart in Manual Operation (2/2)  
(with key kept pressed for 0.5 second or longer)**

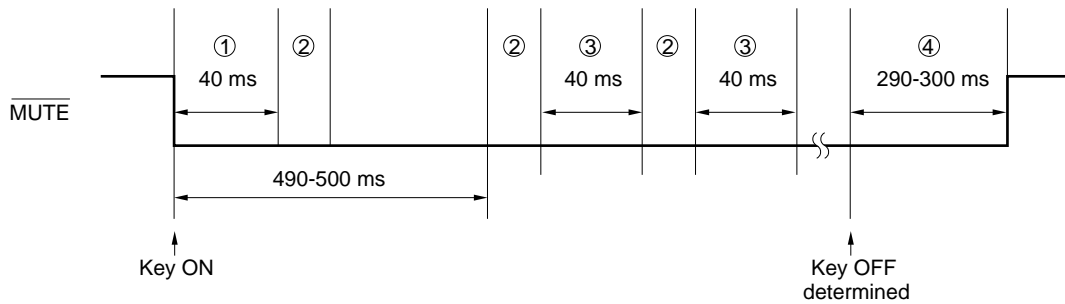

- ① MUTE first-out and beep output
- ② Frequency division ratio setting
- ③ Key repeat time (500 ms for both AM and FM when the band edge has been detected.)
- ④ MUTE last-out output (490-500 ms in band edge detection)

6.1.6 Auto store memory

The operation is started by pressing the **ASM** key when the device is in TUNER mode.

The timing chart below shows the auto store memory operation.

Figure 6-6. Timing Chart in Auto Store Memory

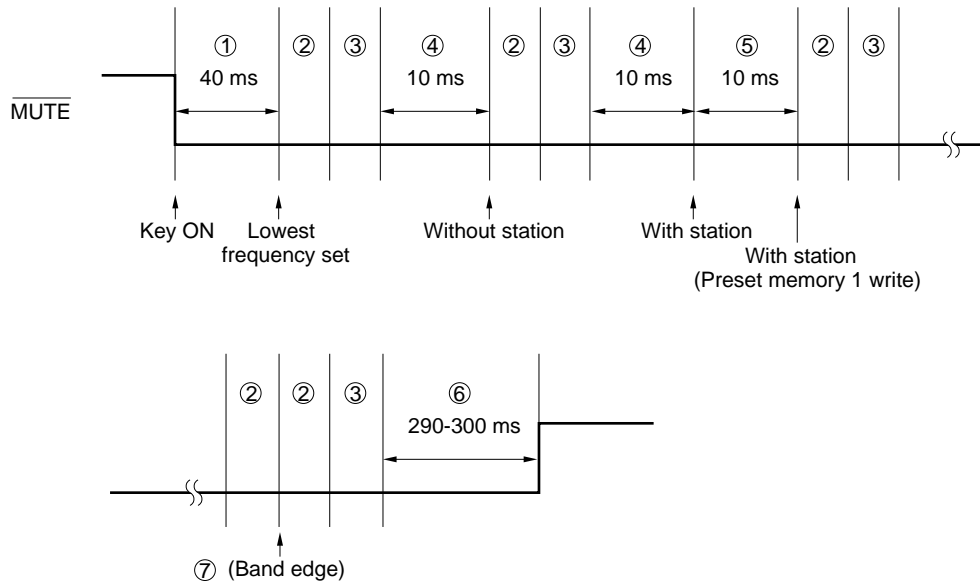

- ① MUTE first-out and beep output
- ② Frequency division ratio setting
- ③ PLL lock wait
- ④ SD stability wait (1)
- ⑤ SD stability wait (2)
- ⑥ MUTE last-out output
- ⑦ ASM end. Sorted in the ascending order of the frequency to call preset memory M1. If no station is detected, the frequency before pressing the key is retained. If the relevant station is detected after writing the preset memories up to M6, it is compared with the SD levels of the written preset memories and stored whose SD levels is high.

**6.1.7 AF switchover**

There are two types of AF switchover operations.

- (1) AF switchover of all stations at once (refer to **Figure 6-7**)
- (2) AF switchover of a station at a time (Interval 5 seconds (refer to **Figure 6-8**))

The timing charts of the respective operations are shown below and on the following page.  
 For conditions for occurrence of the AF operations, please refer to **5.2.4 AF (Alternative Frequency)**.

- (1) All-Station AF switchover at once

**Figure 6-7. Timing Chart for All-Station AF Switchover**

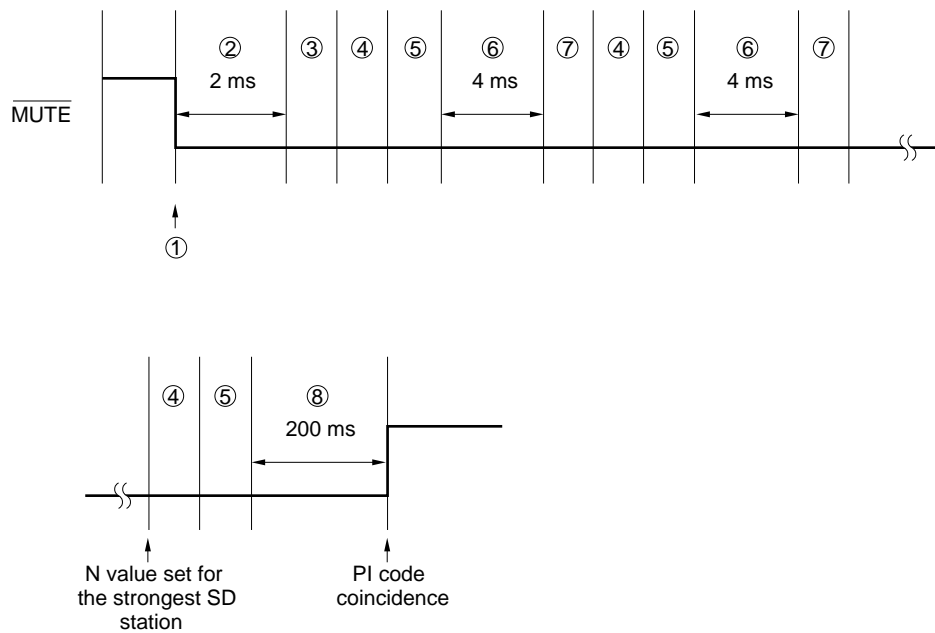

- ① Occurrence of AF switchover condition
- ② MUTE first-out wait
- ③ SD sort (Stations with SD are determined beforehand on the AF list and sorted in the order of the frequency.)
- ④ Frequency division ratio setting
- ⑤ PLL lock wait
- ⑥ SD judgment wait
- ⑦ SD level comparison
- ⑧ PI code input, judgment wait

(2) One-station AF switchover at a time

Figure 6-8. Timing Chart for One-Station AF Switchover (1/2)

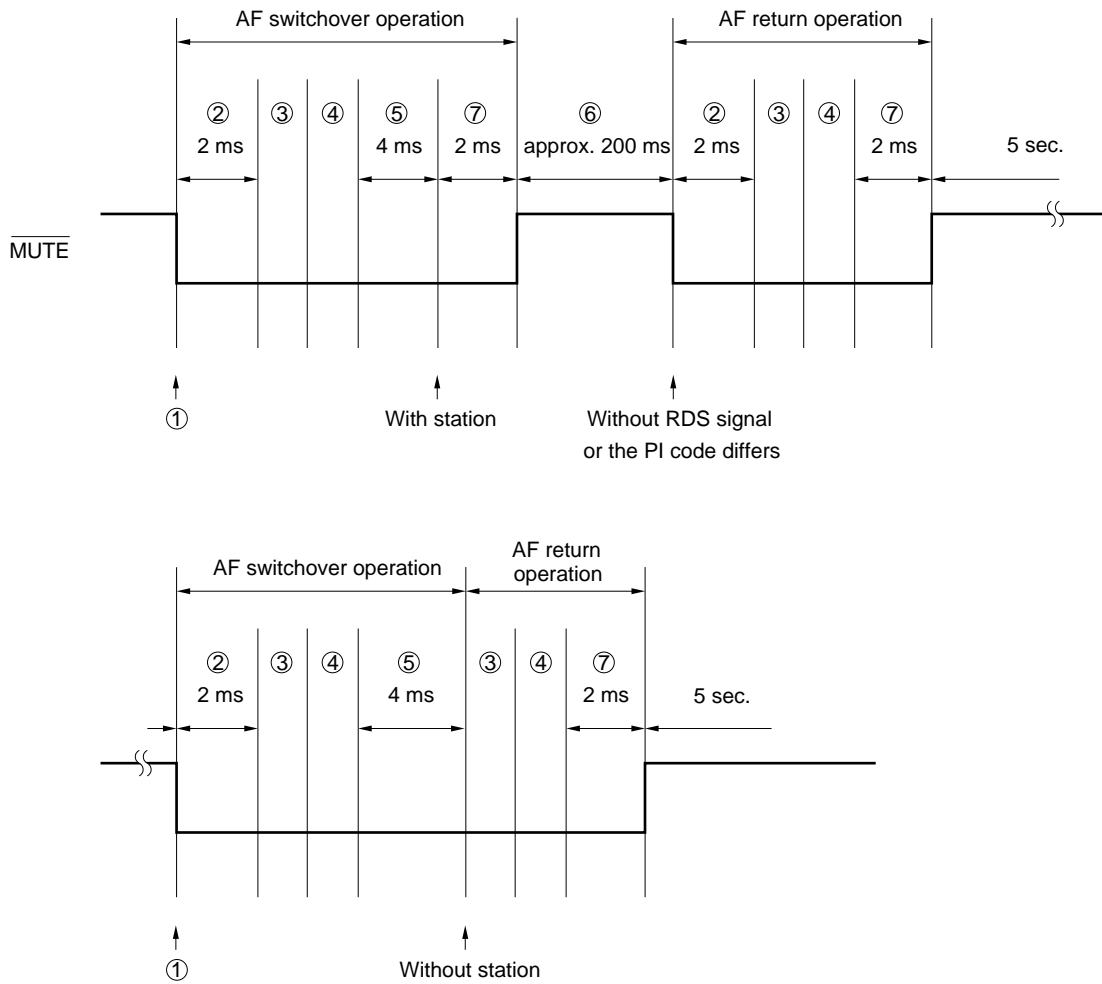

- ① Occurrence of AF switchover condition
- ② MUTE first-out wait
- ③ Frequency division ratio setting
- ④ PLL lock wait
- ⑤ SD stability/IF count wait
- ⑥ RDS station detection/PI code input wait
- ⑦ MUTE last-out output

Figure 6-8. Timing Chart for One-Station AF Switchover (2/2)

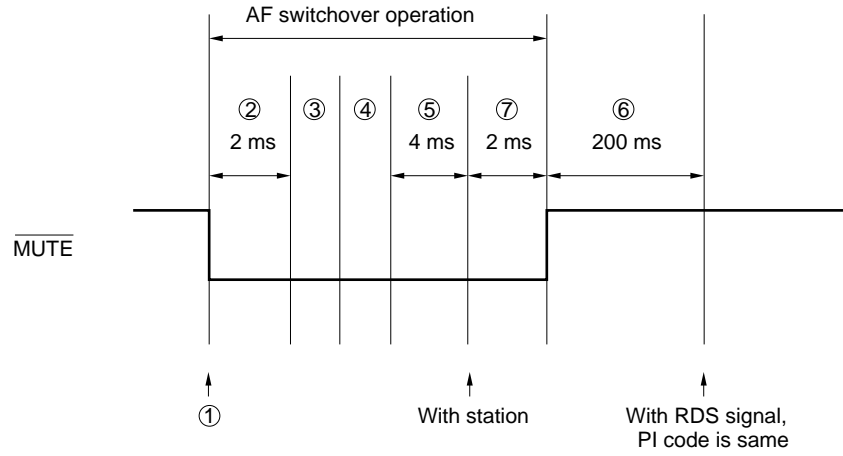

- ① Occurrence of AF switchover condition
- ② MUTE first-out wait
- ③ Frequency division ratio setting
- ④ PLL lock wait
- ⑤ SD stability/IF count wait
- ⑥ RDS station detection/PI code input wait
- ⑦ MUTE last-out output

### 6.2 Mode Switchover

The mode pin switchover and the MUTE output timing chart are shown below.

#### 6.2.1 RADIO mode ↔ TAPE/CD mode

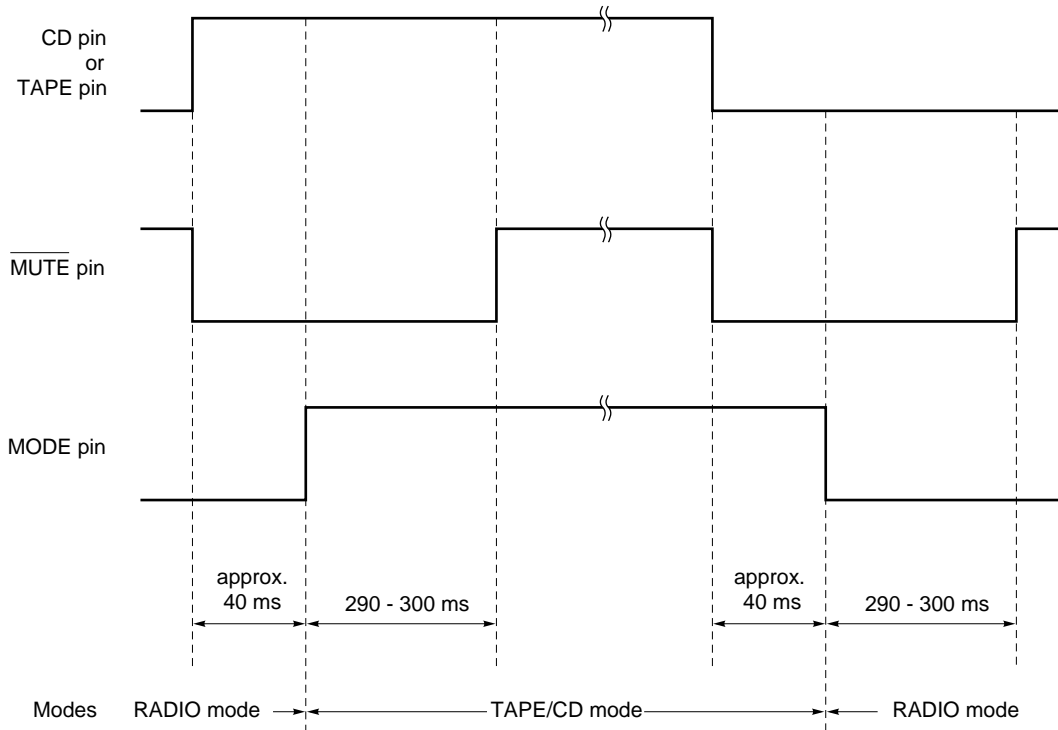

6.2.2 Traffic information broadcasting/PTY alarm ↔ TAPE/CD mode (TP/SK mode)

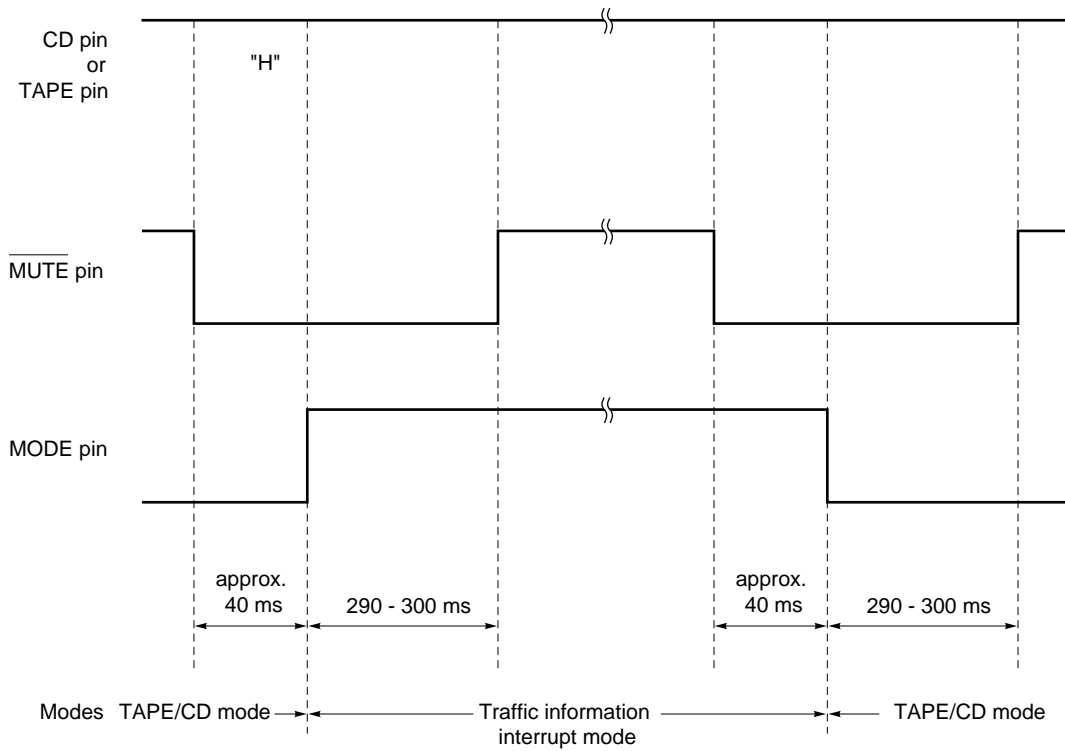

6.3 CE Pin

The MUTE output timing charts in level change of the CE pin are shown below.

6.3.1 Low level → high level

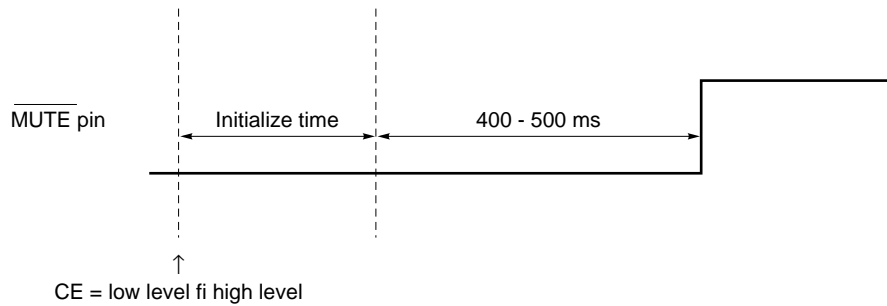

6.3.2 High level → low level

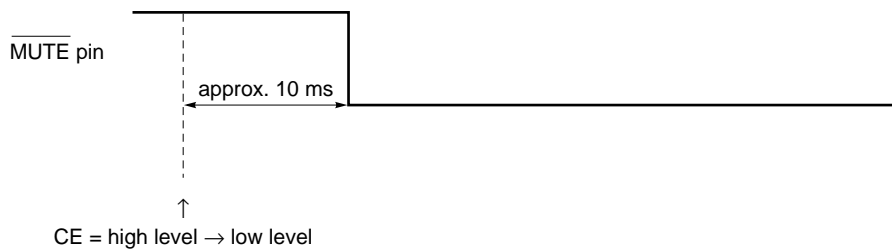

### 6.4 Detecting the Detachable Panel

Timing chart for eliminating chattering

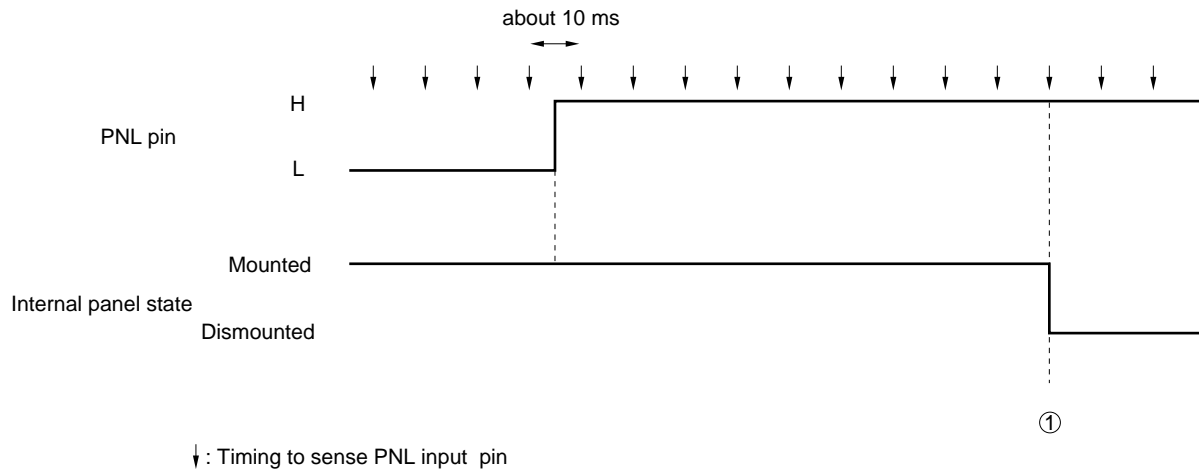

If high level on the PNL pin is detected 10 times in succession, the panel is regarded as being dismantled (①) and the power is unconditionally turned off.

Detection of the mounted state proceeds according to the same timing.

If the panel is regarded as being mounted, the power state is checked when the panel is dismantled. If the panel was dismantled in the power-on state, power-on is set. (For details about power transitions, refer to 6.5.2.

**Timing of POWER ON ↔ POWER OFF transitions by detachable panel)**



6.5 Power Control

6.5.1 TIMING of POWER ON ↔ OFF transitions by POWER key

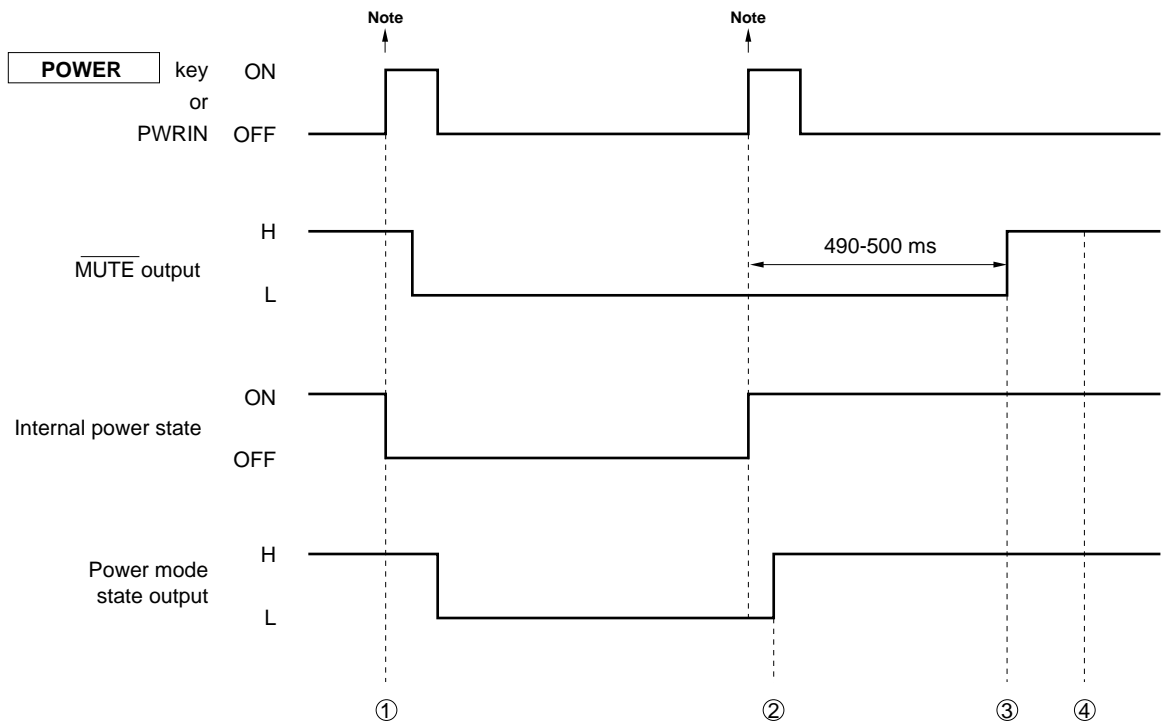

- ① The power-off port state is set, the tuner is turned off, and serial communication is broken. But if the initialize diode CLKDSP = 1 (short-circuited with diode), the operations of breaking serial communication and turning off the LCD power output are not implemented.
- ② If initialize diode CLKDSP = 0 (open), the LCD power output is turned on with the same timing.
- ③ Tuner is turned on, sound source mode is started, serial communication is started and call back for the last preset memory is started (If the sound source is the tuner, mute on remains.)
- ④ Call for last preset memory is completed.

**Note** Timing for detecting key and panel changes (time to eliminate chattering is not included).

6.5.2 Timing of POWER ON ↔ POWER OFF transitions by detachable panel

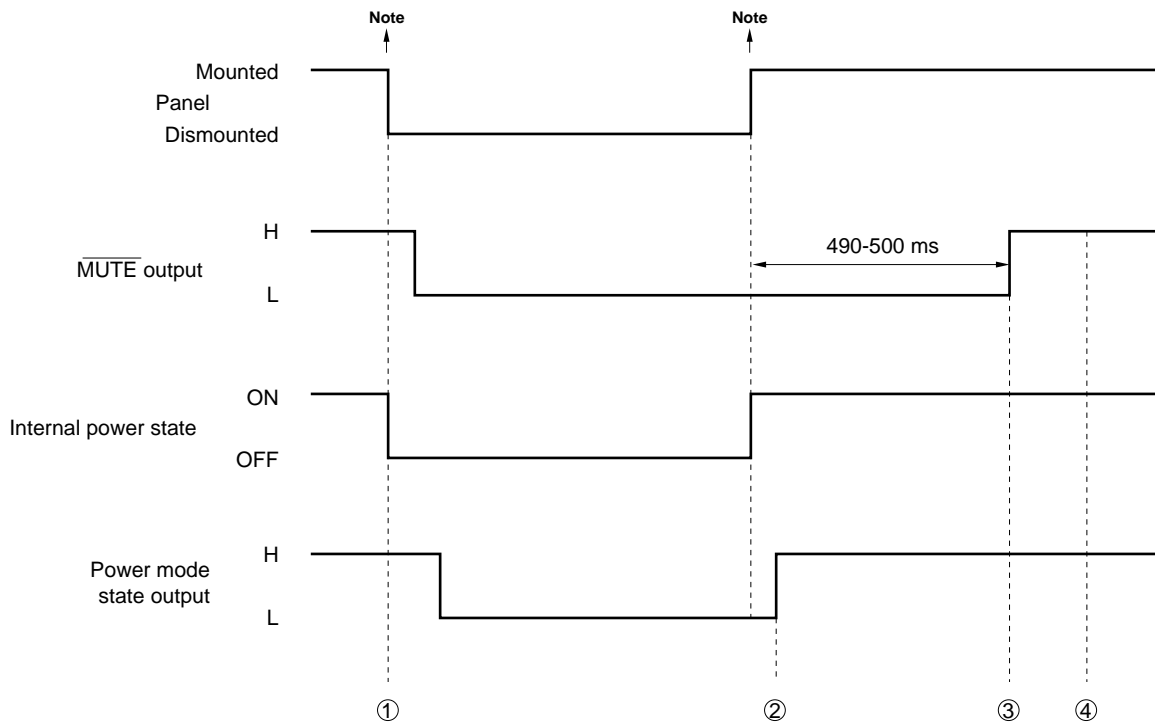

- ① The power-off port state is set, the tuner is turned off, and serial communication is broken. But if the initial setting diode CLKDSP = 1 (shorted with diode), the operations of breaking serial communication and turning off the LCD power output are not implemented.
- ② The LCD power pin is also turned ON by this timing.
- ③ Tuner is turned on, sound source mode is started, serial communication is started and call back for the last preset memory is started (If the sound source is the tuner, mute on remains.)
- ④ Call for last preset memory is completed.

**Note** Timing for detecting key and panel changes (time to eliminate chattering is not included).

## 7. LCD PANEL

### 7.1 LCD Panel Configuration

An example of the LCD panel configuration is shown below.

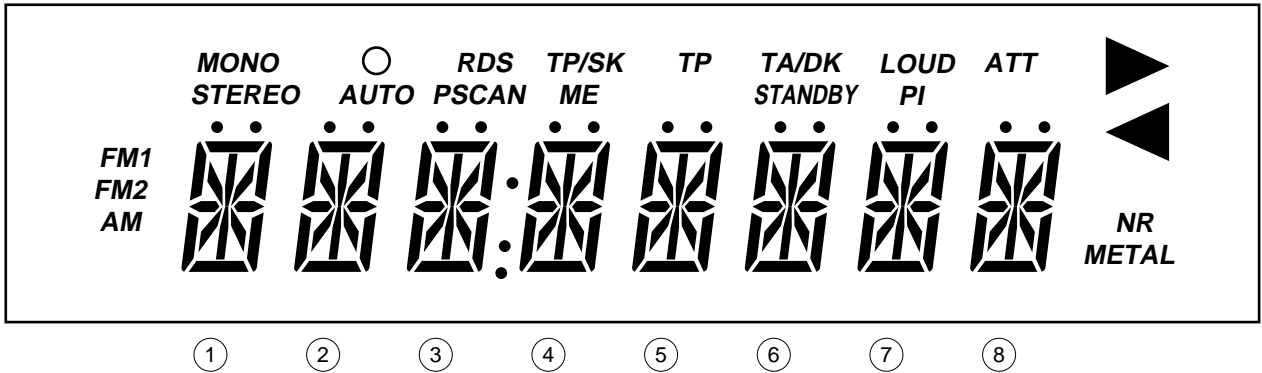

For inquiries on the LCD panel, please contact the following address or phone.

Address : 1-4-33 Kitakyuhoji, Yao-shi, Osaka 581

Administration Section of Displayer Product Division, Hoshiden, Ltd.

Tel : 0729-93-1010 (key number)

### 7.2 LCD Pin Assignment

The LCD pin assignment table of μPD16431A is shown in Table 7-1.

① to ⑧ indicate the column locations of the 14 segments. "a" to "n" show the following 14 segments respectively.

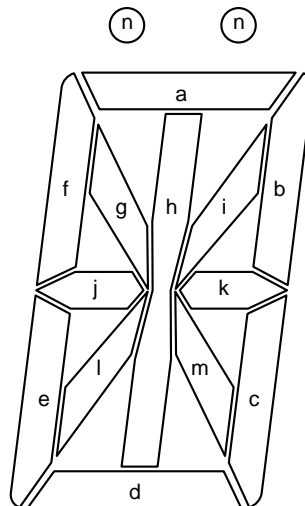

Table 7-1. LCD Pin Assignment Table of μPD16431A (1/2)

Common Segment	COM <sub>1</sub> (21)	COM <sub>2</sub> (22)	COM <sub>3</sub> (23)	COM <sub>4</sub> (24)
SEG <sub>1</sub> (25)	⑧ n	⑧ b	⑧ c	—
SEG <sub>2</sub> (26)	⑧ i	⑧ k	⑧ m	—
SEG <sub>3</sub> (27)	⑧ a	⑧ h	⑧ d	—
SEG <sub>4</sub> (28)	⑧ g	⑧ j	⑧ l	—
SEG <sub>5</sub> (29)	PI	⑧ f	⑧ e	ATT
SEG <sub>6</sub> (30)	—	—	—	—
SEG <sub>7</sub> (31)	⑦ n	⑦ b	⑦ c	LOUD
SEG <sub>8</sub> (32)	⑦ i	⑦ k	⑦ m	—
SEG <sub>9</sub> (33)	⑦ a	⑦ h	⑦ d	—
SEG <sub>10</sub> (34)	⑦ g	⑦ j	⑦ l	—
SEG <sub>11</sub> (35)	STANDBY	⑦ f	⑦ e	▶
SEG <sub>12</sub> (36)	—	—	—	—
SEG <sub>13</sub> (37)	⑥ n	⑥ b	⑥ c	TA/DK
SEG <sub>14</sub> (38)	⑥ i	⑥ k	⑥ m	—
SEG <sub>15</sub> (39)	⑥ a	⑥ h	⑥ d	—
SEG <sub>16</sub> (40)	⑥ g	⑥ j	⑥ l	—
SEG <sub>17</sub> (41)	ME	⑥ f	⑥ e	◀
SEG <sub>18</sub> (42)	—	—	—	—
SEG <sub>19</sub> (43)	⑤ n	⑤ b	⑤ c	TP
SEG <sub>20</sub> (44)	⑤ i	⑤ k	⑤ m	—
SEG <sub>21</sub> (45)	⑤ a	⑤ h	⑤ d	—
SEG <sub>22</sub> (46)	⑤ g	⑤ j	⑤ l	—
SEG <sub>23</sub> (47)	—	⑤ f	⑤ e	TP/SK
SEG <sub>24</sub> (48)	—	—	—	—
SEG <sub>25</sub> (49)	④ n	④ b	④ c	—
SEG <sub>26</sub> (50)	④ i	④ k	④ m	—
SEG <sub>27</sub> (51)	④ a	④ h	④ d	—
SEG <sub>28</sub> (52)	④ g	④ j	④ l	—
SEG <sub>29</sub> (53)	PSCAN	④ f	④ e	:
SEG <sub>30</sub> (54)	—	NR	METAL	—
SEG <sub>31</sub> (55)	③ n	③ b	③ c	.
SEG <sub>32</sub> (56)	③ i	③ k	③ m	—
SEG <sub>33</sub> (57)	③ a	③ h	③ d	—
SEG <sub>34</sub> (58)	③ g	③ j	③ l	—
SEG <sub>35</sub> (59)	AUTO	③ f	③ e	RDS
SEG <sub>36</sub> (60)	—	—	—	—

— : Unused

**Remark** The value in parentheses indicates the pin number of μPD16431A.

Table 7-1. LCD Pin Assignment Table of  $\mu$ PD16431A (2/2)

Common Segment	COM <sub>1</sub> (21)	COM <sub>2</sub> (22)	COM <sub>3</sub> (23)	COM <sub>4</sub> (24)
SEG <sub>37</sub> (61)	② n	② b	② c	○
SEG <sub>38</sub> (62)	② i	② k	② m	—
SEG <sub>39</sub> (63)	② a	② h	② d	—
SEG <sub>40</sub> (64)	② g	② j	② l	—
SEG <sub>41</sub> (65)	STEREO	② f	② e	MONO
SEG <sub>42</sub> (66)	—	—	—	—
SEG <sub>43</sub> (67)	① n	① b	① c	—
SEG <sub>44</sub> (68)	① i	① k	① m	—
SEG <sub>45</sub> (69)	① a	① h	① d	—
SEG <sub>46</sub> (70)	① g	① j	① l	—
SEG <sub>47</sub> (71)	FM2	① f	① e	FM1
SEG <sub>48</sub> (72)	AM	—	—	—



— : Unused

**Remark** The value in parentheses indicates the pin number of  $\mu$ PD16431A.



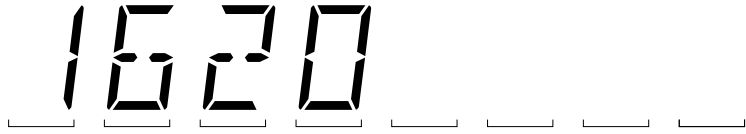
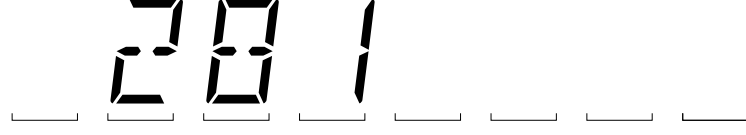

7.3 Description of LCD Panel Display

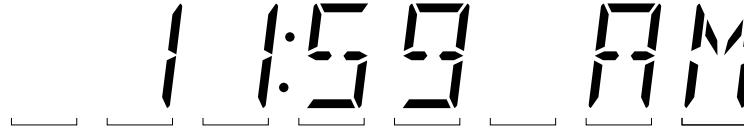
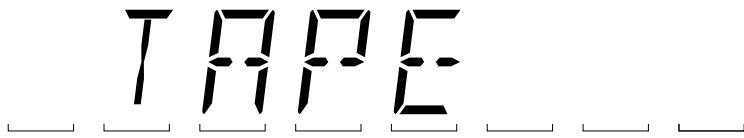
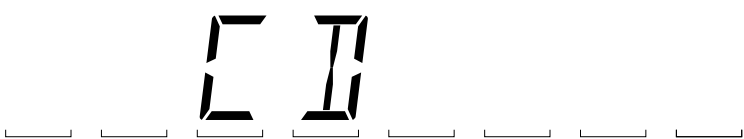
Display	Description
MONO	Indicates that the device is in forced monaural voice output mode. Inverted by pressing the <b>MONO</b> key while receiving the FM band in RADIO mode.
○	Indicates that the broadcasting station being currently received is an RDS station. Lit when an RDS station is received on the FM band.
RDS	Indicates that the device is in RDS mode. Inverted by pressing the <b>RDS</b> key upon reception of FM band during RADIO mode.
TP/SK	Indicates that the device is in TP/SK mode. Inverted by pressing the <b>TP/SK</b> key upon reception of FM band during RADIO mode.
TP	Indicates that the broadcasting station currently being received is broadcasting the traffic information. Lit when the TP signal of an RDS broadcasting station or the $\overline{SK}$ signal of a VF broadcasting station is detected.
TA/DK	Indicates that the broadcasting station currently being received is broadcasting the traffic information. Lit when the TA signal of an RDS broadcasting station or the $\overline{DK}$ signal of a VF broadcasting station is detected.
LOUD	Indicates the loudness is ON. Inverted by pressing the <b>ATT/LOUD</b> key for more than 2 seconds.
ATT	Indicates the attenuator is ON. Inverted by pressing the <b>ATT/LOUD</b> key for less than 2 seconds.
STEREO	Indicates that the $\overline{STEREO}$ signal is being input. Lit when the $\overline{STEREO}$ pin is at a low level in the FM band. Always unlit in MONO mode.
AUTO	Indicates that the tuning mode of the radio is AUTO (SEEK). Inverted by pressing the <b>AUTO</b> key during RADIO mode.
PSCAN	Indicates that the device is in preset memory scan operation. Lit if the device is placed in preset memory scan operation by the <b>PSCAN</b> key.
ME	Indicates that the device is in the preset memory write status. Lit if the device is placed in preset memory write status by the <b>ME</b> key.
STANDBY	Indicates the traffic information is in the state of standby during CD/tape mode. Also indicates it is upon traffic information interrupt/alarm interrupt during RADIO mode.
PI	Indicates the mode to check a PI code when preset memory is called. Inverted by pressing the <b>PI</b> key upon reception of FM band during RADIO mode.
FM1 FM2 AM	Indicates the receiving band of the radio.
NR	Indicates that the device is in noise reduction mode. Inverted by pressing the <b>NR</b> key during TAPE mode.
METAL	Indicates that the device is in metal tape compatible mode. Inverted by pressing the <b>METAL</b> key during TAPE mode.
▶ ◀	Indicates the running direction of the tape. In TAPE mode, “▶” is lit when the R/L pin is low level; and “◀” when high level.

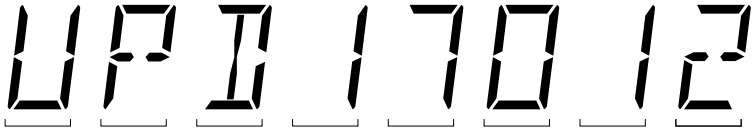
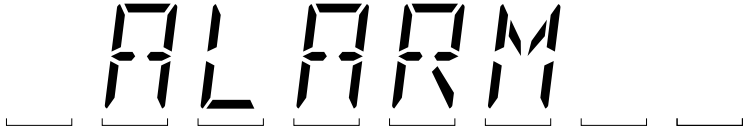

Display	Description
<p>14-segment display area</p>	<p>Displays the following:</p> <ul style="list-style-type: none"> <li>(1) Receiving frequency</li> <li>(2) Clock</li> <li>(3) Tape</li> <li>(4) CD</li> <li>(5) PS (Program Service Name)</li> <li>(6) PTY alarm</li> <li>(7) Traffic information being broadcast in TP/SK mode</li> <li>(8) Electronic volume</li> <li>(9) Reception band and preset code</li> <li>(10) Identification during auto store memory operation</li> </ul> <p>(1) Receiving frequency display</p> <p>&lt;1&gt; FM band (108.00 MHz)</p> <div style="text-align: center;">  <p>The display shows the frequency 108.00 MHz. The digits are formed by 14 segments. The first four digits are '1', '0', '8', and '0', followed by a decimal point and two more '0's. Each digit is positioned above a small horizontal bracket.</p> </div> <p>&lt;2&gt; MW band (1620 kHz)</p> <div style="text-align: center;">  <p>The display shows the frequency 1620 kHz. The digits are formed by 14 segments. The first three digits are '1', '6', and '2', followed by a '0'. Each digit is positioned above a small horizontal bracket.</p> </div> <p>&lt;3&gt; LW band (281 kHz)</p> <div style="text-align: center;">  <p>The display shows the frequency 281 kHz. The digits are formed by 14 segments. The first two digits are '2' and '8', followed by a '1'. Each digit is positioned above a small horizontal bracket.</p> </div>

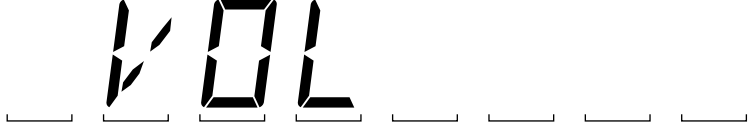
Display	Description
<p>14-segment display area</p>	<p>(2) Clock display                      The 12- or 24-hr time display can be selected by the CLK24 switch of the initialize diode.                      The “:(colon)” display can be flashed at 1 Hz by the FLASH switch of the initialize diode.</p> <p>&lt;1&gt; When CLK24 = 1 (9:00 p.m.)</p>  <p>&lt;2&gt; When CLK24 = 0 (9:00 p.m.)</p>  <p>&lt;3&gt; When CLK24 = 0 (11:59 a.m.)</p>  <p>(3) Tape display                      When in TAPE mode, the display is as follows.</p>  <p>(4) CD display                      When in CD mode, the display is as follows.</p> 

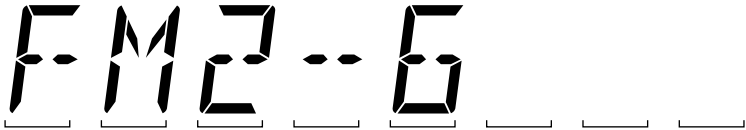

Display	Description	
14-segment display area	(5) PS display If PS data is input, 8-digit PS is displayed. <div style="text-align: center; margin: 10px 0;">  </div>	
	(6) PTY alarm display If PTY alarm is input, the display is as follows. <div style="text-align: center; margin: 10px 0;">  </div>	
	(7) Traffic information broadcasting display in TP/SK mode If the traffic information is being broadcast in TP/SK mode, the display is as follows. <div style="text-align: center; margin: 10px 0;">  </div>	
	(8) Electronic volume display <1> When adjusting volume <div style="text-align: center; margin: 10px 0;">  </div> <div style="text-align: right; margin-top: 5px;">                         Displays the value of the volume                     </div>	
	<2> When adjusting bass <div style="text-align: center; margin: 10px 0;">  </div> <div style="display: flex; justify-content: space-around; margin-top: 5px;"> <span>Note 1</span> <span>Note 2</span> </div>	
	<b>Notes</b> 1. Indicates “+” and “-” for bass adjustment. 2. Displays the value of bass	

Display	Description
14-segment display area	<p data-bbox="402 201 673 226">&lt;3&gt; When adjusting treble</p> <div data-bbox="516 268 1256 403" style="text-align: center;"> <p>The display shows the word 'TRE' in a 14-segment font. The 'T' has a small horizontal bar at the top. The 'R' has a small horizontal bar at the top. The 'E' has a small horizontal bar at the top. To the right of the 'E', there are two small rectangular boxes labeled 'Note 1' and 'Note 2'. Below the display, there are seven small rectangular boxes, each with a small horizontal bar at the top, representing the segments of the display.</p> </div> <p data-bbox="402 436 971 491"><b>Notes</b> 1. Indicates “+” and “-” for treble adjustment. 2. Displays the value of treble</p>
	<p data-bbox="402 520 634 546">&lt;4&gt; Adjusting balance</p> <div data-bbox="516 583 1256 718" style="text-align: center;"> <p>The display shows the word 'BAL' in a 14-segment font. The 'B' has a small horizontal bar at the top. The 'A' has a small horizontal bar at the top. The 'L' has a small horizontal bar at the top. To the right of the 'L', there are two small rectangular boxes labeled 'Note 1' and 'Note 2'. Below the display, there are seven small rectangular boxes, each with a small horizontal bar at the top, representing the segments of the display.</p> </div> <p data-bbox="402 751 995 806"><b>Notes</b> 1. Indicates “L” and “R” for balance adjustment. 2. Displays the value of balance</p>
	<p data-bbox="402 835 669 861">&lt;5&gt; When adjusting fader</p> <div data-bbox="516 907 1256 1041" style="text-align: center;"> <p>The display shows the word 'FAD' in a 14-segment font. The 'F' has a small horizontal bar at the top. The 'A' has a small horizontal bar at the top. The 'D' has a small horizontal bar at the top. To the right of the 'D', there are two small rectangular boxes labeled 'Note 1' and 'Note 2'. Below the display, there are seven small rectangular boxes, each with a small horizontal bar at the top, representing the segments of the display.</p> </div> <p data-bbox="402 1075 971 1129"><b>Notes</b> 1. Indicates “F” and “R” for fader adjustment. 2. Displays the value of fader</p>

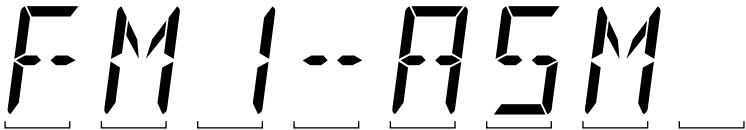
Display	Description
14-segment display area	(9) Band/preset display
	<1> When receiving preset 1 of FM1
	
	<2> When receiving preset 6 of FM2
	
<3> When receiving other than preset memory of AM	
	
(10) Identification during auto store memory operation	
<b>Example</b> During the auto store memory operation of FM1	
	

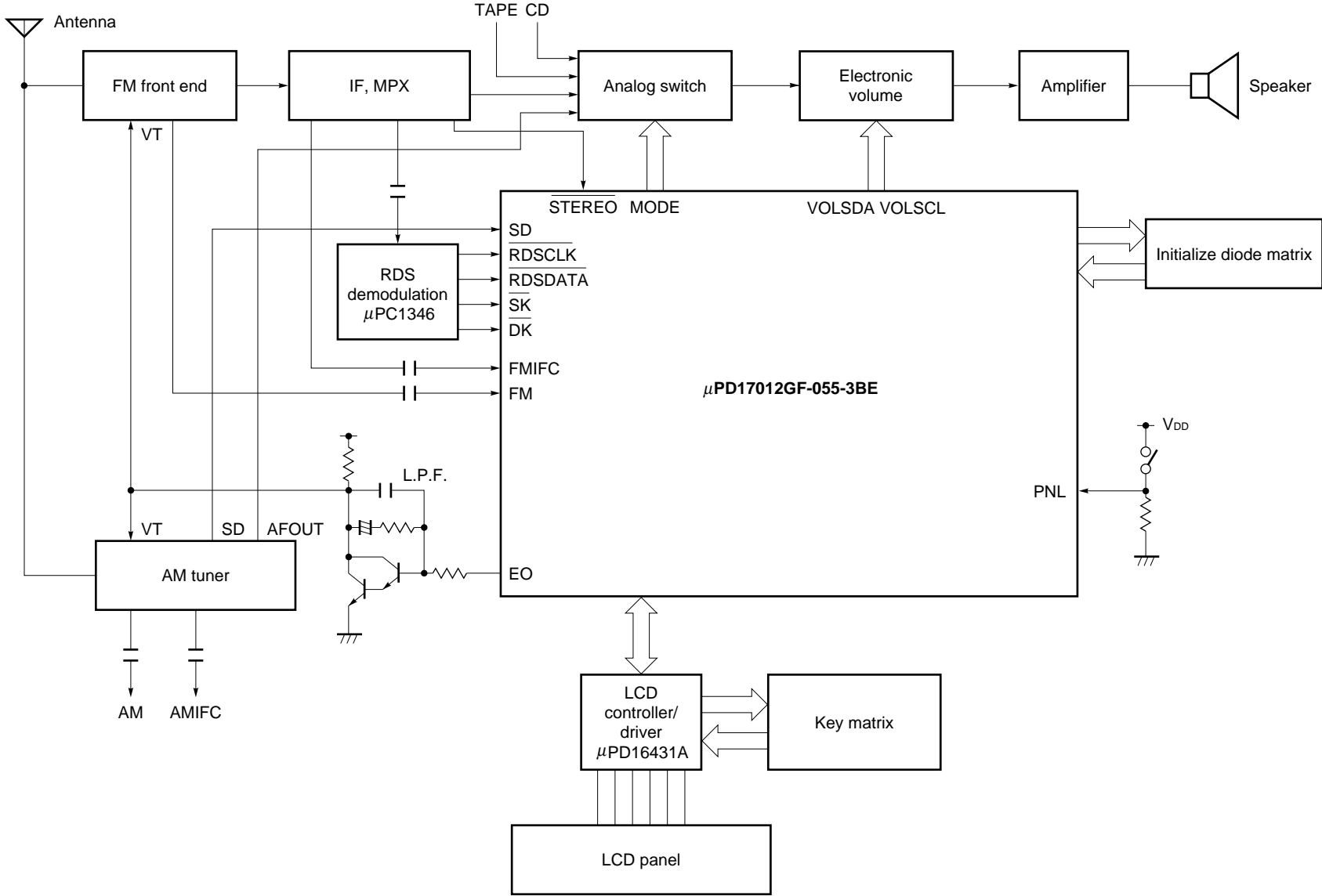

8. SYSTEM CONFIGURATION EXAMPLE

9. ELECTRICAL SPECIFICATIONS (PRELIMINARY)

Absolute Maximum Ratings (T<sub>A</sub> = 25 °C)

Item	Symbol	Condition	Rating	Unit
Supply voltage	V <sub>DD</sub>		-0.3 to +6.0	V
Input voltage	V <sub>I</sub>		-0.3 to V <sub>DD</sub> +0.3	V
Output voltage	V <sub>O</sub>	Other than P0C <sub>0</sub> -P0C <sub>3</sub>	-0.3 to V <sub>DD</sub> +0.3	V
High-level output current	I <sub>OH</sub>	One pin	-12.0	mA
		Total of all pins	-20.0	mA
Low-level output current	I <sub>OL</sub>	One pin	15.0	mA
		Total of all pins	30.0	mA
Output pressure proof	V <sub>BDS</sub>	P0C <sub>0</sub> -P0C <sub>3</sub>	14.0	V
Total power dissipation	P <sub>T</sub>		200	mW
Operating ambient temperature	T <sub>A</sub>	All functions operation	-40 to +85	°C
Storage temperature	T <sub>stg</sub>		-55 to +125	°C

**Caution** If the absolute maximum rating of even one of the items above is exceeded, product quality may deteriorate. In other words, the absolute maximum rating is the rating value which if exceeded, may result in damage to the product. Be certain not to exceed the absolute maximum rating.

Recommended Operation Range (T<sub>A</sub> = -40 to +85 °C)

Item	Symbol	Condition	MIN.	TYP.	MAX.	Unit
Supply voltage	V <sub>DD1</sub>	All functions operation	4.5	5.0	5.5	V
	V <sub>DD2</sub>	CPU operation, PLL stop	3.5	5.0	5.5	V
Data retention voltage	V <sub>DDR</sub>	Crystal oscillation stop	2.3		5.5	V
Output pressure proof	V <sub>BDS</sub>	P0C <sub>0</sub> -P0C <sub>3</sub>			12.0	V
Supply voltage rise time	t <sub>rise</sub>	V <sub>DD</sub> = 0 → 4.5 V			500	ms

DC Characteristics (T<sub>A</sub> = -40 to +85 °C, V<sub>DD</sub> = 5 V ±10 %)

Item	Symbol	Condition		MIN.	TYP.	MAX.	Unit
Supply current	I <sub>DD1</sub>	CPU operation, PLL stop; X <sub>IN</sub> pin sine wave input (f <sub>IN</sub> = 4.5 MHz, V <sub>IN</sub> = V <sub>DD</sub> )			1.0	2.0	mA
	I <sub>DD2</sub>	CPU operation, PLL stop, X <sub>IN</sub> pin sine wave input (f <sub>IN</sub> = 4.5 MHz, V <sub>IN</sub> = V <sub>DD</sub> ) HALT command used			0.5	1.0	mA
Data retention voltage	V <sub>DDR1</sub>	In crystal oscillation	Uses the power failure detection method by timer FF	3.5			V
	V <sub>DDR2</sub>	In crystal oscillation	Uses the power failure detection method by timer FF	2.3			V
	V <sub>DDR3</sub>	stop	Retention of data memory	2.0			V
Data retention current	I <sub>DDR1</sub>	In crystal oscillation	V <sub>DD</sub> = 5 V, T <sub>A</sub> = 25 °C		2.0	4.0	μA
	I <sub>DDR2</sub>				2.0	20.0	μA
	I <sub>DDR3</sub>	stop	V <sub>DD</sub> = 2.3 V, T <sub>A</sub> = 25 °C		1.0	2.0	μA
	I <sub>DDR4</sub>			V <sub>DD</sub> = 2.3 V		1.0	10.0
Intermediate level output voltage	V <sub>OM</sub>	COM <sub>0</sub> -COM <sub>2</sub>	V <sub>DD</sub> = 5.0 V	2.3		2.7	V
High-level input voltage	V <sub>IH1</sub>	P0A <sub>1</sub> , P0B <sub>0</sub> -P0B <sub>3</sub> , P1A <sub>0</sub> -P1A <sub>2</sub> , P1B <sub>0</sub> -P1B <sub>3</sub> , P1D <sub>0</sub> -P1D <sub>3</sub>		0.7 V <sub>DD</sub>		V <sub>DD</sub>	V
	V <sub>IH2</sub>	P0A <sub>0</sub> , P0A <sub>2</sub> , CE, INT		0.8 V <sub>DD</sub>		V <sub>DD</sub>	V
	V <sub>IH3</sub>	P0D <sub>0</sub> -P0D <sub>3</sub>		0.6 V <sub>DD</sub>		V <sub>DD</sub>	V
Low-level input voltage	V <sub>IL1</sub>	P0A <sub>1</sub> , P0B <sub>0</sub> -P0B <sub>3</sub> , P0D <sub>0</sub> -P0D <sub>3</sub> , P1A <sub>0</sub> -P1A <sub>2</sub> , P1B <sub>0</sub> -P1B <sub>3</sub> , P1D <sub>0</sub> -P1D <sub>3</sub>		0		0.2 V <sub>DD</sub>	V
	V <sub>IL2</sub>	P0A <sub>0</sub> , P0A <sub>2</sub> , CE, INT		0		0.2 V <sub>DD</sub>	V
High-level output current	I <sub>OH1</sub>	P0A <sub>0</sub> -P0A <sub>2</sub> , P0B <sub>0</sub> -P0B <sub>3</sub> , P1A <sub>0</sub> -P1A <sub>2</sub> , P1C <sub>0</sub> -P1C <sub>3</sub> , P1D <sub>0</sub> -P1D <sub>3</sub>		V <sub>OH</sub> = V <sub>DD</sub> -1 V	-1.0		mA
	I <sub>OH2</sub>	LCD <sub>0</sub> -LCD <sub>19</sub> , EO		V <sub>OH</sub> = V <sub>DD</sub> -1 V	-1.0		mA
Low-level output current	I <sub>OL1</sub>	P0A <sub>0</sub> -P0A <sub>2</sub> , P0B <sub>0</sub> -P0B <sub>3</sub> , P1A <sub>0</sub> -P1A <sub>2</sub> , P1C <sub>0</sub> -P1C <sub>3</sub> , P1D <sub>0</sub> -P1D <sub>3</sub>		V <sub>OL</sub> = 1 V	1.0		mA
	I <sub>OL2</sub>	LCD <sub>0</sub> -LCD <sub>19</sub> , EO		V <sub>OL</sub> = 1 V	1.0		mA
	I <sub>OL3</sub>	P0C <sub>0</sub> -P0C <sub>3</sub>		V <sub>OL</sub> = 1 V	10		mA
High-level input current	I <sub>IH1</sub>	VCOH pin pull-down		V <sub>IH</sub> = V <sub>DD</sub>	0.1		mA
	I <sub>IH2</sub>	VCOL pin pull-down		V <sub>IH</sub> = V <sub>DD</sub>	0.1		mA
	I <sub>IH3</sub>	X <sub>IN</sub> pin pull-down		V <sub>IH</sub> = V <sub>DD</sub>	0.1		mA
	I <sub>IH4</sub>	P0D <sub>0</sub> -P0D <sub>3</sub> pin pull-down		V <sub>IH</sub> = V <sub>DD</sub>	10		150 μA
Output off leakage current	I <sub>L1</sub>	P0C <sub>0</sub> -P0C <sub>3</sub>		V <sub>OH</sub> = 12 V		1.0	μA
	I <sub>L2</sub>	EO		V <sub>OH</sub> = V <sub>DD</sub> , V <sub>OL</sub> = 0 V		±1.0	μA

**AC Characteristics (T<sub>A</sub> = -40 to +85 °C, V<sub>DD</sub> = 4.5 to 5.5 V)**

Item	Symbol	Condition	MIN.	TYP.	MAX.	Unit
Operating frequencies	f <sub>IN1</sub>	VCOL pin MF mode sine wave input V <sub>IN</sub> = 0.15 V <sub>P-P</sub>	0.90		3.0	MHz
		VCOL pin MF mode sine wave input V <sub>IN</sub> = 0.3 V <sub>P-P</sub>	0.50		20	MHz
	f <sub>IN2</sub>	VCOL pin HF mode sine wave input V <sub>IN</sub> = 0.15 V <sub>P-P</sub>	5		25	MHz
		VCOL pin HF mode sine wave input V <sub>IN</sub> = 0.3 V <sub>P-P</sub>	5		40	MHz
	f <sub>IN3</sub>	VCOH pin VHF mode sine wave input V <sub>IN</sub> = 0.15 V <sub>P-P</sub>	60		130	MHz
		VCOH pin VHF mode sine wave input V <sub>IN</sub> = 0.3 V <sub>P-P</sub>	30		250	MHz
	f <sub>IN4</sub>	AMIFC pin AMIF count mode sine wave input V <sub>IN</sub> = 0.3 V <sub>P-P</sub>	0.3		1.0	MHz
	f <sub>IN5</sub>	AMIFC pin AMIF count mode sine wave input V <sub>IN</sub> = 0.1 V <sub>P-P</sub>	0.44		0.46	MHz
	f <sub>IN6</sub>	FMIFC pin FMIF count mode sine wave input V <sub>IN</sub> = 0.3 V <sub>P-P</sub>	5		15	MHz
f <sub>IN7</sub>	FMIFC pin FMIF count mode sine wave input V <sub>IN</sub> = 0.1 V <sub>P-P</sub>	10.5		10.9	MHz	

**A/D Converter Characteristics (T<sub>A</sub> = -40 to +85 °C, V<sub>DD</sub> = 5 V ± 10 %)**

Item	Symbol	Condition	MIN.	TYP.	MAX.	Unit
A/D conversion resolution					6	bit
A/D conversion overall error				±1.0	±1.5	LSB

**Reference Characteristics (T<sub>A</sub> = 25 °C, V<sub>DD</sub> = 5.0 V)**

Item	Symbol	Condition	MIN.	TYP.	MAX.	Unit
Supply current	I <sub>DD3</sub>	CPU and PLL operation, VCOH pin sine wave input (f <sub>IN</sub> = 130 MHz, V <sub>IN</sub> = 0.3 V <sub>P-P</sub> )		12		mA
	I <sub>DD4</sub>	CPU and PLL operation, VCOH pin sine wave input (f <sub>IN</sub> = 250 MHz, V <sub>IN</sub> = 0.3 V <sub>P-P</sub> )		13		mA
High-level output current	I <sub>OH3</sub>	COM <sub>0</sub> -COM <sub>2</sub> V <sub>OH</sub> = V <sub>DD</sub> -1 V		-300		μA
Intermediate-level output current	I <sub>OL4</sub>	COM <sub>0</sub> -COM <sub>2</sub> V <sub>OL</sub> = 1 V		300		μA
Low-level output current	I <sub>OM1</sub>	COM <sub>0</sub> -COM <sub>2</sub> V <sub>OH</sub> = V <sub>DD</sub> -1 V		-25		μA
	I <sub>OM2</sub>	COM <sub>0</sub> -COM <sub>2</sub> V <sub>OL</sub> = 1 V		25		μA

10. PACKAGE DRAWING

64 PIN PLASTIC QFP (14×20)

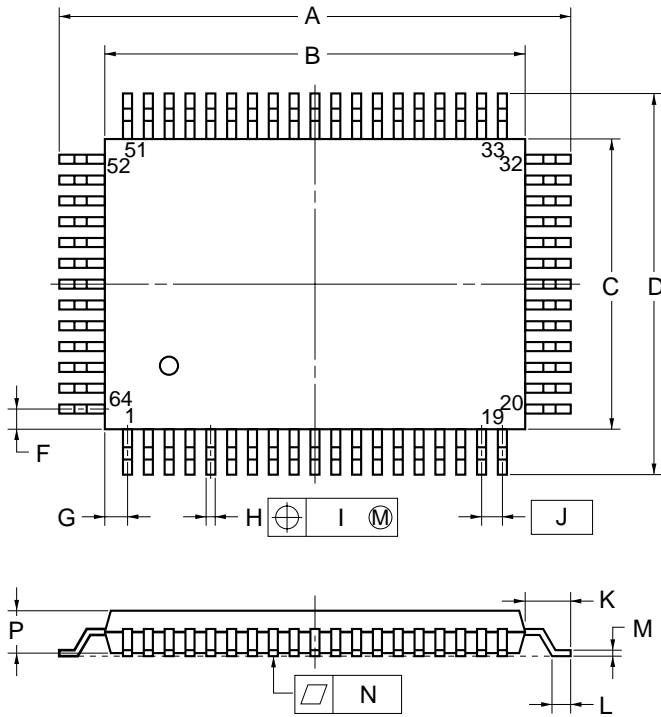

detail of lead end

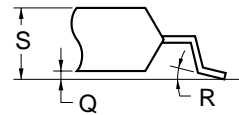

NOTE

Each lead centerline is located within 0.20 mm (0.008 inch) of its true position (T.P.) at maximum material condition.

ITEM	MILLIMETERS	INCHES
A	23.6±0.4	0.929±0.016
B	20.0±0.2	0.795 <sup>+0.008</sup> <sub>-0.009</sub>
C	14.0±0.2	0.551 <sup>+0.009</sup> <sub>-0.008</sub>
D	17.6±0.4	0.693±0.016
F	1.0	0.039
G	1.0	0.039
H	0.40±0.10	0.016 <sup>+0.004</sup> <sub>-0.005</sub>
I	0.20	0.008
J	1.0 (T.P.)	0.039 (T.P.)
K	1.8±0.2	0.071 <sup>+0.008</sup> <sub>-0.009</sub>
L	0.8±0.2	0.031 <sup>+0.009</sup> <sub>-0.008</sub>
M	0.15 <sup>+0.10</sup> <sub>-0.05</sub>	0.006 <sup>+0.004</sup> <sub>-0.003</sub>
N	0.10	0.004
P	2.7	0.106
Q	0.1±0.1	0.004±0.004
R	5°±5°	5°±5°
S	3.0 MAX.	0.119 MAX.

P64GF-100-3B8,3BE,3BR-2



**11. RECOMMENDED SOLDERING CONDITIONS**

Solder the package of this product under the conditions recommended as follows.

For details of the recommended conditions for soldering, please refer to the information document “**Semiconductor Device Mounting Technology Manual**” (IEI-1207).

For soldering methods and conditions other than those recommended below, please contact NEC sales personnel.

**Table 11-1. Soldering Conditions for Surface-Mount Type**

**μPD17012GF-055-3BE: 64-pin plastic QFP (14 × 20 mm)**

Soldering Method	Soldering Condition	Recommended Condition Symbol
Infrared reflow	Package peak temperature : 235 °C; time : within 30 secs (210 °C or more); count: 2 max.; day limit : 7 days <sup>Note</sup> (hereafter, pre-baked for 20 hrs at 125 °C) <b>&lt;Caution&gt;</b> (1) Start second reflow after device temperature (which has risen because of first reflow) has returned to room temperature. (2) Do not clean flux with water after first reflow.	IR35-207-2
VPS	Package peak temperature : 215 °C; time : within 40 secs (200 °C or more); count: 2 max.; day limit : 7 days <sup>Note</sup> (hereafter, pre-baked for 20 hrs at 125 °C) <b>&lt;Caution&gt;</b> (1) Start second reflow after device temperature (which has risen because of first reflow) has returned to room temperature. (2) Do not clean flux with water after first reflow.	VP15-207-2
Wave soldering	Solder bath temperature: no more than 260 °C; time : within 10 secs; count: once; preheating temperature : 120 °C max. (package surface temperature); day limit : 7 days <sup>Note</sup> (hereafter, pre-baked for 20 hours at 125 °C)	WS60-207-1
Pin part heating	Pin temperature : no more than 300 °C; time : within 3 secs (per device side)	—

**Note** Refers to the number of days for storage after the dry pack is opened. The storage conditions are 25 °C and no more than 65 % RH.

**Caution** Avoid using multiple soldering methods at the same time (except the pin part heating method).

APPENDIX DESCRIPTION OF ELECTRONIC VOLUME CONTROL

Appendix 1. Function of Electronic Volume

The μPD17012GF-055 uses electronic volume to control and select the sound.  
The electronic volume functions are as follows.

- (1) Volume adjustment (0 to 50 steps)
- (2) Bass adjustment (-7 to +7 steps)
- (3) Treble adjustment (-7 to +7 steps)
- (4) Balance adjustment (L7 to R7 steps)
- (5) Fader adjustment (F7 to R7 steps)
- (6) Loudness (On/Off)
- (7) Attenuator (On/Off)
- (8) Sound selector

For adjustments for each function, refer to the descriptions of the **SELECT** key and **VOLUP** / **VOLDOWN** key.

Appendix 2. Description of the Electronic Volume Control

The μPD17012GF-055 uses an electronic volume IC to control and select the sound.

The μPD17012GF-055 transfers the initial data settings to electronic volume about 480-500 ms after the transition from initial low level to high level at the PWROUT pin, when the power supply for the V<sub>DD</sub> pin is turned on (power on reset).

In addition, the μPD17012GF-055 uses the I<sup>2</sup>C bus.

The pin configuration between the μPD17012GF-055 and the electronic volume is as follows.

Figure A-1. Pin Configuration of Electronic Volume

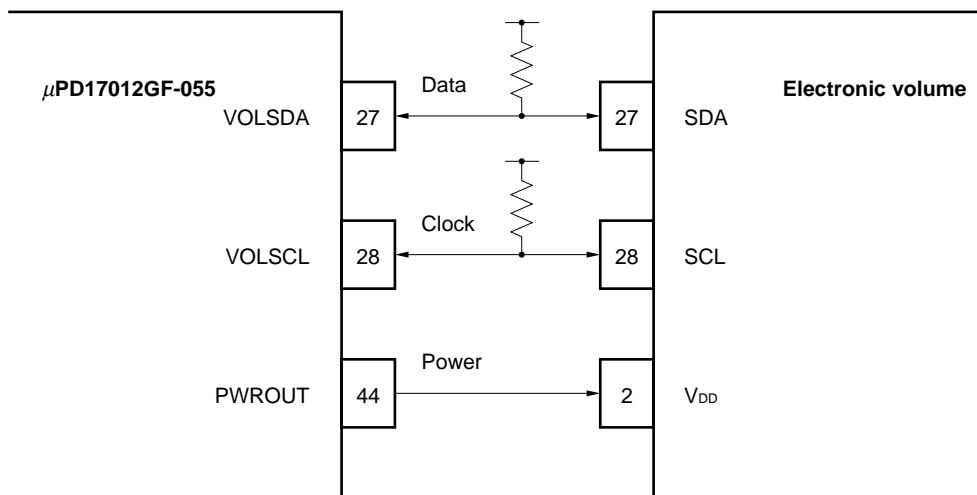

### Appendix 3. Initial Electronic Volume Value Settings

When initial power is supplied to the  $\mu$ PD17012GF-055, the electronic volume state settings are as follows.

Function	Initial Value
Volume	20 steps
Bass	0 steps
Treble	0 steps
Balance	0 steps
Fader	0 steps
Loudness	Off
Attenuator	Off

Also, when CE is reset, the state settings prior to the CE reset are retained.

Appendix.4 Electronic Volume Data Output Timing

Appendix 4.1 Initial data setting output timing

The timing of initial data setting output to the electronic volume is shown in Figure A-2.

Figure A-2. Initial Setting Data Output Timing

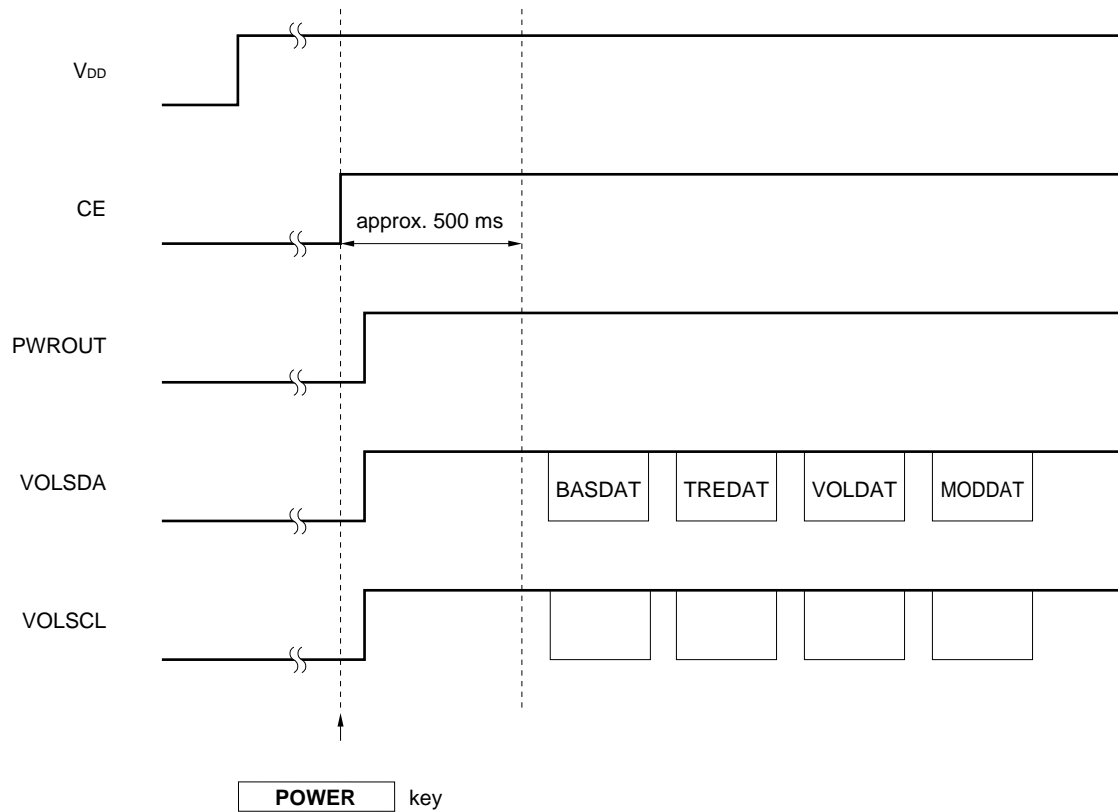

- BASDAT : Bass initial data setting (0 steps)
- TREDAT : Treble initial data setting (0 steps)
- VOLDAT : Volume initial data setting (Master: 20 steps, balance fader: 0 steps)
- MODDAT : Sound source, loudness data setting (loudness off)

**Appendix 4.2 Volume data output timing**

The timing of volume data output to the electronic volume is shown in Figure A-3. When adjusting the balance fader, output is according to the following procedure.

**Figure A-3. Volume Data Output Timing**

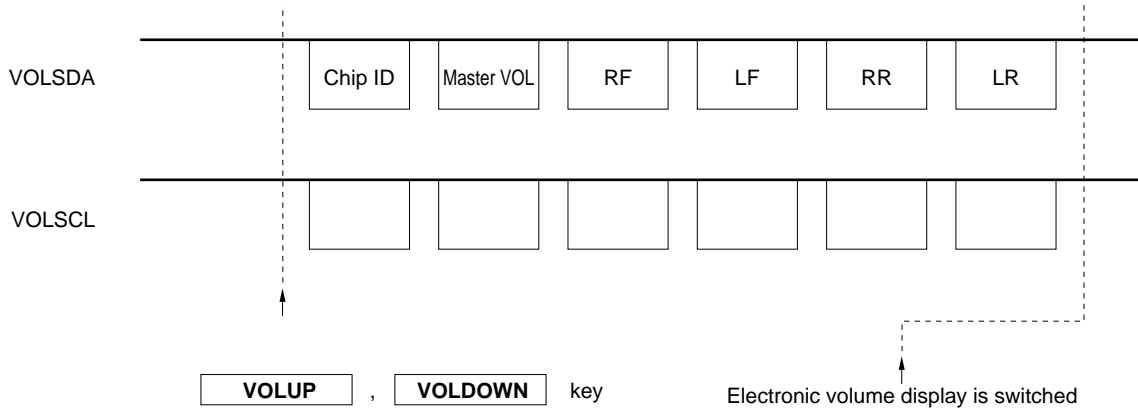

- Master VOL : 0 to 50 steps
- RF : Right front volume data
- LF : Left front volume data
- RR : Right rear volume data
- LR : Left rear volume data

**Appendix 4.3 Loudness data output timing**

The timing of loudness data output to the electronic volume is shown in Figure A-4.

**Figure A-4. Loudness Data Output Timing**

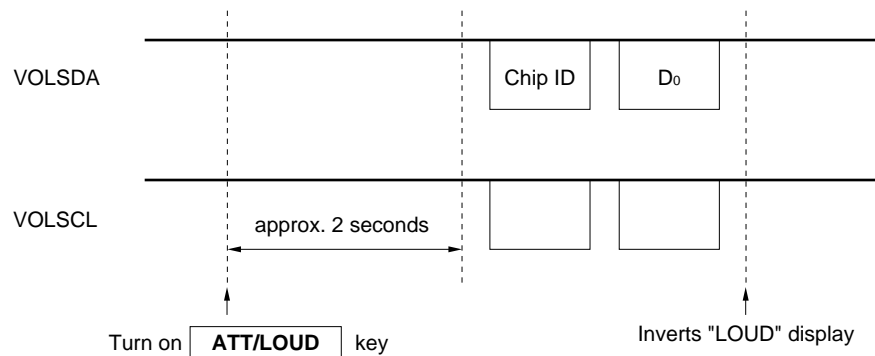

- D<sub>0</sub> : Sound/loudness data

**Appendix 4.4 Attenuator data output timing**

The timing of attenuator data output to the electronic volume is shown in Figure A-5.

**Figure A-5. Attenuator Data Output Timing**

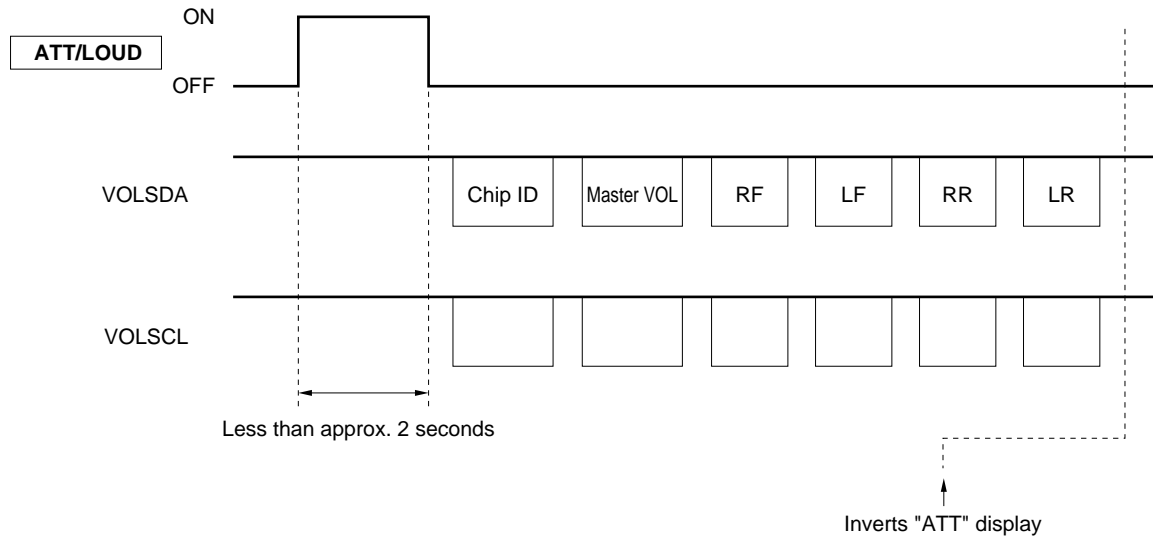

- Master VOL : 0 to 50 steps
- RF : Right front volume data
- LF : Left front volume data
- RR : Right rear volume data
- LR : Left rear volume data

When the attenuator is turned on, -20 dB is subtracted from each of master VOL, RF, LF, RR, LR, and the result is output.

**Appendix 4.5 Sound source switchover data output timing**

The timing sound source switchover data output to the electronic volume is shown in Figure A-6.

**Figure A-6. Voice Source Switchover Data Output Timing**

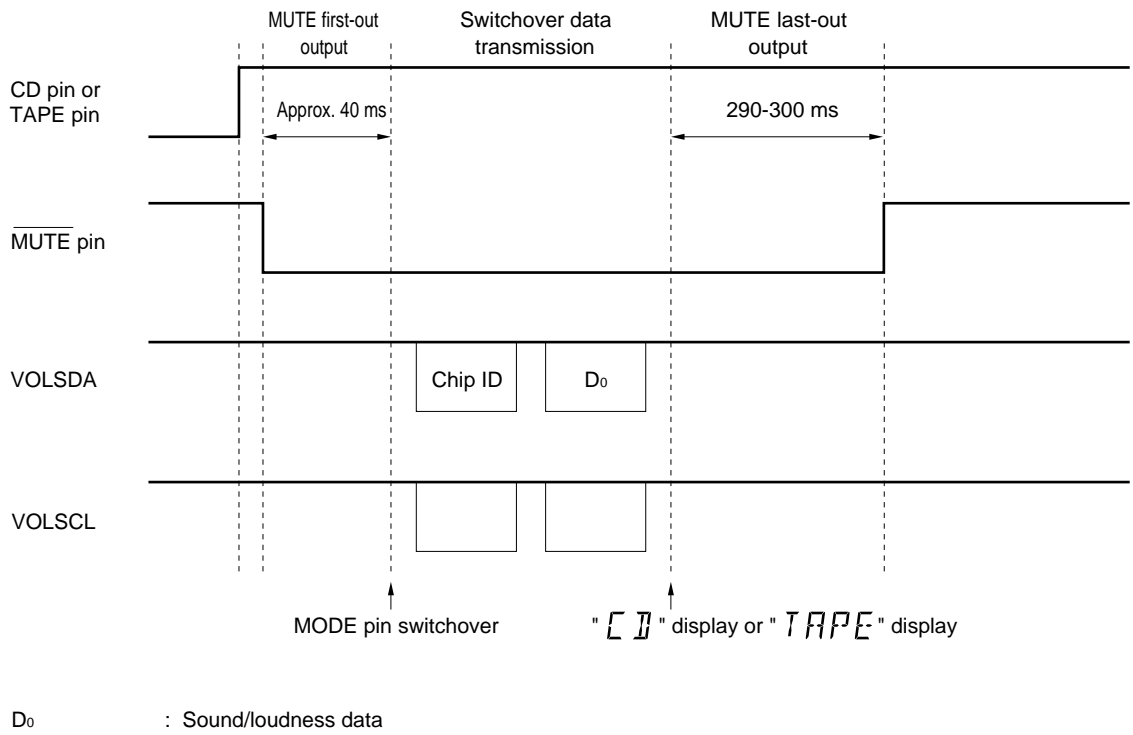

**Appendix 4.6 Bass data output timing**

The timing of bass data output to the electronic volume is shown in Figure A-7.

**Figure A-7. Bass Data Output Timing**

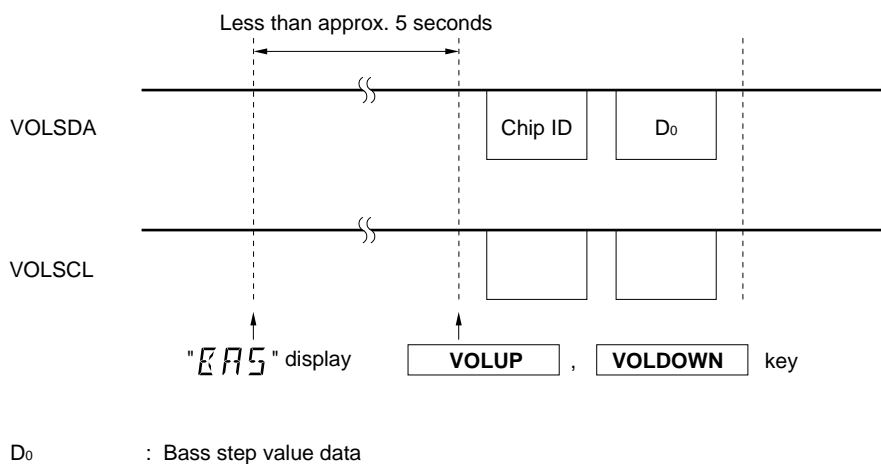

Appendix 4.7 Treble data output timing

The timing of treble data output to the electronic volume is shown in Figure A-8.

Figure A-8. Treble Data Output Timing

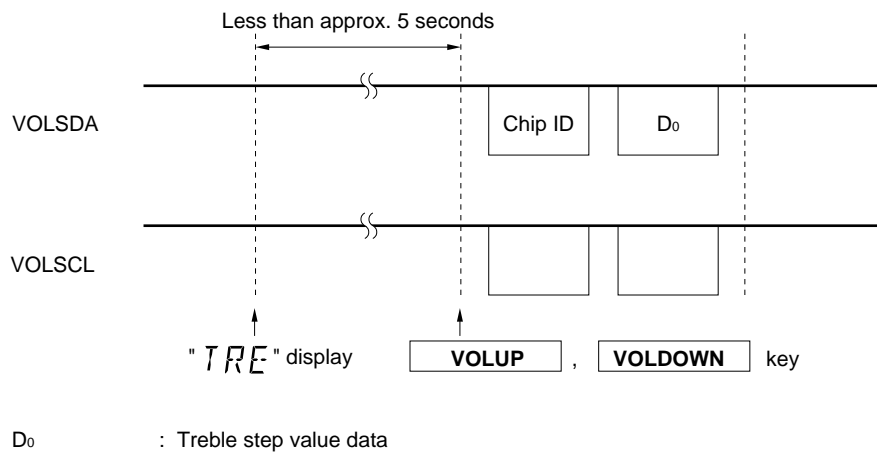



## NOTES FOR CMOS DEVICES

### ① PRECAUTION AGAINST ESD FOR SEMICONDUCTORS

**Note:** Strong electric field, when exposed to a MOS device, can cause destruction of the gate oxide and ultimately degrade the device operation. Steps must be taken to stop generation of static electricity as much as possible, and quickly dissipate it once, when it has occurred. Environmental control must be adequate. When it is dry, humidifier should be used. It is recommended to avoid using insulators that easily build static electricity. Semiconductor devices must be stored and transported in an anti-static container, static shielding bag or conductive material. All test and measurement tools including work bench and floor should be grounded. The operator should be grounded using wrist strap. Semiconductor devices must not be touched with bare hands. Similar precautions need to be taken for PW boards with semiconductor devices on it.

### ② HANDLING OF UNUSED INPUT PINS FOR CMOS

**Note:** No connection for CMOS device inputs can be cause of malfunction. If no connection is provided to the input pins, it is possible that an internal input level may be generated due to noise, etc., hence causing malfunction. CMOS device behave differently than Bipolar or NMOS devices. Input levels of CMOS devices must be fixed high or low by using a pull-up or pull-down circuitry. Each unused pin should be connected to  $V_{DD}$  or GND with a resistor, if it is considered to have a possibility of being an output pin. All handling related to the unused pins must be judged device by device and related specifications governing the devices.

### ③ STATUS BEFORE INITIALIZATION OF MOS DEVICES

**Note:** Power-on does not necessarily define initial status of MOS device. Production process of MOS does not define the initial operation status of the device. Immediately after the power source is turned ON, the devices with reset function have not yet been initialized. Hence, power-on does not guarantee out-pin levels, I/O settings or contents of registers. Device is not initialized until the reset signal is received. Reset operation must be executed immediately after power-on for devices having reset function.

**[MEMO]**

Purchase of NEC I<sup>2</sup>C components conveys a license under the Philips I<sup>2</sup>C Patent Rights to use these components in an I<sup>2</sup>C system, provided that the system conforms to the I<sup>2</sup>C Standard Specification as defined by Philips.

The export of this product from Japan is regulated by the Japanese government. To export this product may be prohibited without governmental license, the need for which must be judged by the customer. The export or re-export of this product from a country other than Japan may also be prohibited without a license from that country. Please call an NEC sales representative.

The application circuits and their parameters are for references only and are not intended for use in actual design-in's.

No part of this document may be copied or reproduced in any form or by any means without the prior written consent of NEC Corporation. NEC Corporation assumes no responsibility for any errors which may appear in this document.

NEC Corporation does not assume any liability for infringement of patents, copyrights or other intellectual property rights of third parties by or arising from use of a device described herein or any other liability arising from use of such device. No license, either express, implied or otherwise, is granted under any patents, copyrights or other intellectual property rights of NEC Corporation or others.

While NEC Corporation has been making continuous effort to enhance the reliability of its semiconductor devices, the possibility of defects cannot be eliminated entirely. To minimize risks of damage or injury to persons or property arising from a defect in an NEC semiconductor device, customer must incorporate sufficient safety measures in its design, such as redundancy, fire-containment, and anti-failure features.

NEC devices are classified into the following three quality grades:

“Standard”, “Special”, and “Specific”. The Specific quality grade applies only to devices developed based on a customer designated “quality assurance program” for a specific application. The recommended applications of a device depend on its quality grade, as indicated below. Customers must check the quality grade of each device before using it in a particular application.

Standard: Computers, office equipment, communications equipment, test and measurement equipment, audio and visual equipment, home electronic appliances, machine tools, personal electronic equipment and industrial robots

Special: Transportation equipment (automobiles, trains, ships, etc.), traffic control systems, anti-disaster systems, anti-crime systems, safety equipment and medical equipment (not specifically designed for life support)

Specific: Aircrafts, aerospace equipment, submersible repeaters, nuclear reactor control systems, life support systems or medical equipment for life support, etc.

The quality grade of NEC devices in “Standard” unless otherwise specified in NEC's Data Sheets or Data Books. If customers intend to use NEC devices for applications other than those specified for Standard quality grade, they should contact NEC Sales Representative in advance.

Anti-radioactive design is not implemented in this product.