



UM83C021

PRELIMINARY

Hard Disk Controller

Features

- Serializer-deserializer
- Programmable track format, compatible with WD Track format
- External drive select and head select registers for expandability
- With Hardware ECC capability
- Internal phase detector for phase lock oscillator
- Interface options: ST-506, ST-412, ST-412HP, ESDI, FLOPPY, and QIC-36 TAPE

- Sector options: SOFT, HARD, ESDI ADDRESS MARKS, ESDI BYTE and ESDI BYTE CLOCKS
- Recording options: UNENCODED, FM, MFM or RLL
- Error checking and correcting options: ECC or CRC
- Write data options: PULSE, NRZ or NRZI
- Read data options: PULSE, NRZ or NRZI
- TTL compatible inputs and outputs. Outputs drive 8 LSTTL loads

General Description

The UM83C021 Hard Disk Controller is a CMOS LSI device which performs a majority of the functions for controlling floppy drives, Winchester drives and QIC-36 streaming tape drives.

ESDI STEP/SERIAL MODES (10 mbos Winchesters)
 SA-450 (5" and 3" floppies)
 SA800/850 (8" floppies)
 QIC-36 (streaming tape drives)

Interface Options

- ST-506 (non-buffered seek Winchesters)
- ST-412 (buffered seek Winchesters)
- ST-412HP (10 mbos buffered seek Winchesters)

Sector Options

- SOFT-SECTORING (floppy and Winchester)
- HARD-SECTORING (floppy and Winchester)
- ESDI ADDRESS MARKS (ESDI drives)
- ESDI BYTE CLOCKS (ESDI drives)

Pin Configuration

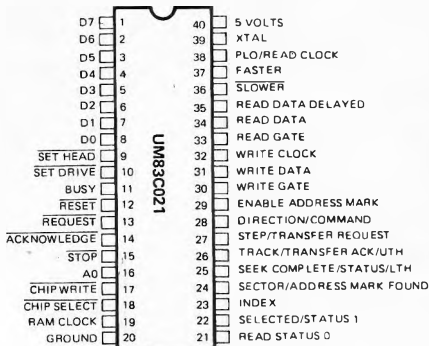

Block Diagram

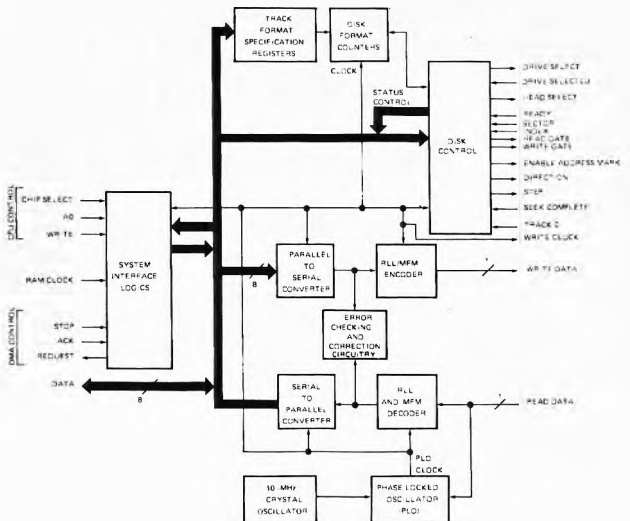

Recording Codes

UNENCODED (for ESDI drives)
 FM (Frequency Modulation)
 MFM (Modified Frequency Modulation)
 RLL (Run Length Limited)

Error Checking

CRC (CCITT CRC-16)
 ECC (4 byte, corrects 11 contiguous erroneous bits)

Data Options

NRZ (non-return to zero)
 NRZI (non-return to zero inverted)
 PULSE

Absolute Maximum Ratings*

Power Supply Voltage, V_{DD} -0.5 to +7.0V
 Input Voltage, V_I -0.5V to V_{DD} +0.5V
 Operating Temperature, T_{OPT} 0°C to +85°C
 Storage Temperature, T_{STG} -65 to +150°C

Track Format

Extensive control over the track format is provided by allowing the length of fields and content of ADDRESS MARKS and identifier bytes, etc. to be programmed into registers.

There are 23 registers related to TRACK FORMAT inside the UM83C021 (Refer to Figure 1). 18 of these registers contain lengths of fields within a track. Others contain "content" information. Length fields are written with length-1 giving them a range of 1 to 256 inclusive. The Data Field Length Register is 2 bytes yielding a maximum data field length of 65,536 bytes. .

***Comments**

Stresses above those listed under "Absolute Maximum Ratings" may cause permanent damage to the device. These are stress ratings only. Functional operation of this device at these or any other conditions above those indicated in the operational sections of this specification is not implied and exposure to absolute maximum rating conditions for extended periods may affect device reliability.

Recommended Operating Conditions

($T_A = 0$ to +70°C, $V_{DD} = 5V \pm 5\%$)

Parameter	Symbol	Limits			Units	Test Conditions
		Min.	Typ.	Max.		
Power Supply Voltage	V_{DD}	4.5	5	5.5	V	
Input Voltage	V_I	0		V_{DD}	V	
Low-level Input Voltage	V_{IL}	0		0.8	V	TTL Level
High-level Input Voltage	V_{IH}	2.0		V_{DD}	V	TTL Level
Input Rise/Fall Times	t_R, t_F	0		10	us	

DC Electrical Characteristics

Parameter	Symbol	Limits			Units	Test Conditions
		Min.	Typ.	Max.		
Static Current	I_L		0.1	200	μA	$V_I = V_{DD}$ or GND
Dynamic Current	I_{DD}		4		μA	1 MHz/cell
Input Current	I_I	0.1		10	μA	$V_I = V_{DD}$ or GND
Low-level Output Current	I_{OL}	3.2	9		mA	$V_{OL} = 0.4V$
High-level Output Current	I_{OH}	1	3		mA	$V_{OH} = V_{DD} - 0.4V$
Low-level Output Voltage	V_{OL}			0.1	V	$I_O = 0$
High-level Output Voltage	V_{OH}	$V_{DD} - 0.1$			V	$I_O = 0$

AC Characteristics

Parameter	Symbol	Limits			Units	Test Conditions
		Min.	Typ.	Max.		
Maximum Operating Frequency	f_{MAX}	DC		20	MHz	
Output Rise Time	t_R		8		ns	$C_L = 15$ pF
Output Fall Time	t_F		4		ns	$C_L = 15$ pF

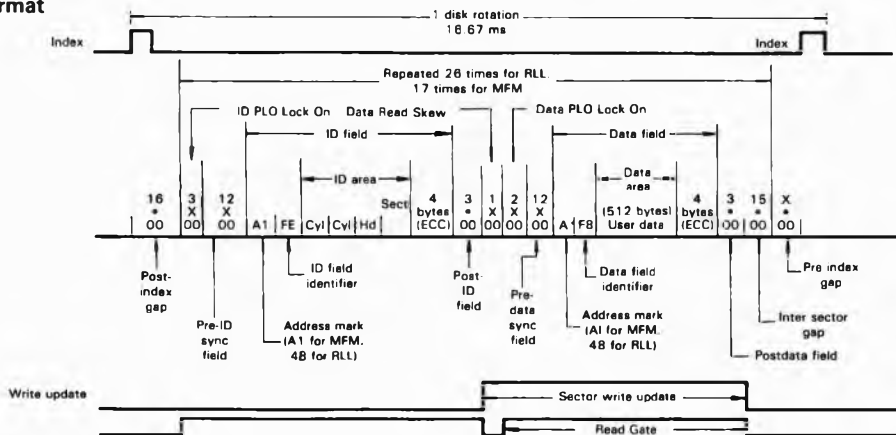
Track Format

Figure 1. UM83C021 Track Format Diagram

HEX Register Address	Function	***Range (In Bytes)
00	POST INDEX GAP	1 – 256
01	ID PLO LOCK-ON	1 – 64
02	PRE ID	1 – 64
03	ID ADDRESS MARK	1 – 4
04	FE BYTE	1 (fixed)
05	ID	1 – 16
06	ID ECC	1 – 4
07	POST ID	1 – 4
08	DATA READ SKEW	1 – 64
09	DATA PLO LOCK-ON	1 – 64
A	PRE DATA	1 – 64
B	DATA ADDRESS MARK	1 – 4
C	F8 BYTE	1 (fixed)
D	DATA FIELD	
	LOW BYTE	1 – 65, 536
0E	HIGH BYTE	
0F	DATA ECC	1 – 4
10	POST DATA	1 – 4
11	INTER-RECORD GAP	1 – 256
12	SECTORS PER TRACK	1 – 256
1C	** GAP VALUE REGISTER	1

*** SET REGISTERS TO n-1 TO GET n BYTE LENGTH

** WRITE 4E for MFM encoding, 33 for RLL encoding

Table 1. Programmable Format Variables

Pin Description

Pin No.	Symbol	Description
1 – 8	DATA LINES D0 – D7 (TO/FROM HOST)	These 8 data lines are used for PROCESSOR and DMA READS and WRITES. They change synchronously with RAM CLOCK rising edge.
9	$\overline{\text{SET HEAD}}$	This signal is used to clock the HEAD ADDRESS, for the drive, into an external HEAD SELECT register. Writing to REGISTER ADDRESS 3D produces a pulse for loading the external head select onto this line.
10	$\overline{\text{SET DRIVE}}$	This signal is the load pulse for the external drive selection register. Writing to REGISTER ADDRESS 3E produces the load pulse on this pin.
11	BUSY	Pin 11 goes high to indicate that the DISK CONTROLLER is busy doing a disk READ or WRITE operation. This pin can be used, if desired, to cause an interrupt for the host processor at the end of a disk READ or WRITE operation.
12	$\overline{\text{RESET}}$	The $\overline{\text{RESET}}$ line is intended to be an initial power on reset line. In order to be efficient, it should go low or be low for a minimum of 100 nanoseconds at the beginning of power on. This line is a hard reset line and will immediately terminate any disk READ or WRITE operations or any other functions and reset the chip to an initial state. It should be used essentially as a power on RESET and is not intended for use as a termination command.

Pin Description (Continued)

Pin No.	Symbol	Description
13	$\overline{\text{REQUEST}}$	The $\overline{\text{REQUEST}}$ line, in conjunction with the $\overline{\text{ACKNOWLEDGE}}$ signal (Pin 14), are the "HANDSHAKING" lines for the DMA data transfer for the chip. The DISK CONTROLLER has a byte of information ready to transfer to RAM or needs a byte of information from RAM to write to the disk when the signal at pin 13 is pulled low. The RAM BUFFER CONTROLLER chip (UM83C002) will respond by driving the $\overline{\text{ACKNOWLEDGE}}$ signal (Pin 14) low and giving the DISK CONTROLLER access to the RAM BUFFER. The DMA transfer operations are run synchronously with the RAM CLOCK signal (Pin 19). The rising edge of the RAM CLOCK pulse defines the cycle boundaries for the RAM.
14	$\overline{\text{ACKNOWLEDGE}}$	<p>This input is driven low to indicate that the requested DMA byte transfer is currently taking place. The $\overline{\text{ACKNOWLEDGE}}$ signal should be a full RAM CLOCK cycle in width.</p> <p>On a disk read operation, the $\overline{\text{ACKNOWLEDGE}}$ signal causes the UM83C021 to gate a byte of data onto the D0 – D7 data lines. On a disk write or verify operation, the $\overline{\text{ACKNOWLEDGE}}$ signal causes the UM83C021 to accept a byte of data from the D0 – D7 data lines.</p> <p>To assure proper "Handshaking" with the $\overline{\text{REQUEST}}$ line, this line must change state while the RAM CLOCK signal is high.</p> <p>If data is not transferred fast enough to keep up with the requirements of the disk or tape, then the OVERRUN/UNDERRUN bit will be set to one (register address 05 bit 1). If this happens, the current disk operation will be terminated at the end of the current sector.</p>
15	$\overline{\text{STOP}}$	<p>This input goes low to indicate the last cycle of a DMA transfer. It is normally driven low by the UM83C002 when the byte counter of the active DMA channel has reached zero. The UM83C021 will continue reading or writing until the end of the current sector is reached and then stop. However, it will not generate any more data requests after the $\overline{\text{STOP}}$ line has been activated. On a sector write, the remainder of the sector will be filled with the last byte that was transferred.</p> <p>This line is ignored unless $\overline{\text{ACKNOWLEDGE}}$ is also low.</p>
16	A0	The UMC DISK CONTROLLER (UM83C021) occupies two I/O port locations selected by the A0 pin. A0 driven low selects the REGISTER ADDRESS POINTER or STATUS REGISTER and A0 driven high selects the READ or WRITE REGISTERS. (Refer to table 2)
17	$\overline{\text{CHIP WRITE}}$	This input is driven by the CPU to indicate whether a register read or write is to be performed. A low indicates a write; a high indicates a read. This line has meaning only when $\overline{\text{CHIP SELECT}}$ is low; and it is ignored when $\overline{\text{CHIP SELECT}}$ is high.
18	$\overline{\text{CHIP SELECT}}$ (CSEL)	The $\overline{\text{CHIP SELECT}}$ line ($\overline{\text{CSEL}}$) is driven low by the processor to read from or write to the registers inside the UM83C021. This signal is intended to be gated by processor's $\overline{\text{ACKNOWLEDGE}}$ signal.
19	RAM CLOCK (RAMCLK)	This clock input synchronizes all CPU and DMA operations of the UM83C021. Cycle boundaries are defined by the rising edge of this clock.

Pin Description (Continued)

Pin No.	Symbol	Description
20	GROUND	Negative Supply
21	READY STATUS 0	This input status line is available to the Host Processor at READ REGISTER 04 Bit 6. This line performs no logical function within the UM83C021 and hence the DRIVE READY signal or any other desired status signal may be connected to this pin.
22	SELECTED or STATUS 1	This input status line is available to the Host Processor at READ REGISTER 04 Bit 7. This line performs no logical function within the UM83C021, hence the DRIVE SELECTED signal or any other desired status signal may be connected to this pin.
23	INDEX	The rising edge of this INDEX signal from the selected drive is used to define the beginning of the track. It occurs once per revolution.
24	SECTOR or ADDRESS MARK FOUND	<p>SECTOR For hard sectored drives, the rising edge of this input defines the beginning of sector except sector 0. The beginning of sector 0 is defined by the rising edge of INDEX.</p> <p>ADDRESS MARK FOUND For soft sectored ESDI drives, the rising edge of this ADDRESS MARK FOUND defines the leading edge of every sector except sector 0. The beginning of sector 0 is defined by the rising edge of INDEX.</p>
25	SEEK COMPLETE or STATUS or LTH	<p>SEEK COMPLETE The SEEK COMPLETE input is available to the Host Processor as STATUS REGISTER Bit 2.</p> <p>STATUS For ESDI drives, the serial status line is input at this pin and is available to the Host Processor as STATUS REGISTER Bit 2.</p> <p>LTH (LOWER TAPE HOLE) For QIC-36 tapes the LOWER TAPE HOLE signal is input at this pin and is available to the Host Processor as STATUS REGISTER Bit 2.</p>
26	TRACK 0 or TRANSFER ACK or UTH	<p>TRACK 0 For ST-506 type drives, the TRACK 0 signal is input at this pin and is available to the Host Processor as STATUS REGISTER Bit 1.</p> <p>TRANSFER ACK (ESDI DISK) For ESDI drives, the TRANSFER ACKNOWLEDGE signal is input at this pin and is available to the Host Processor as STATUS REGISTER Bit 1.</p> <p>UTH (UPPER TAPE HOLE – QIC-36 TAPE) For QIC-36 tapes, the UPPER TAPE HOLE signal is input at this pin and is available to the Host Processor as STATUS REGISTER Bit 1.</p>

Pin Description (Continued)

Pin No.	Symbol	Description
27	STEP TRANSFER REQUEST	<p>STEP This output is the STEP pulses for ST-506 drives. This line goes high whenever a one is written to register 1F bit 0. This line goes low whenever a zero is written to register 1F bit 0.</p> <p>TRANSFER REQUEST This output is used for TRANSFER REQUEST for ESDI drives.</p>
28	DIRECTION COMMAND	<p>DIRECTION This output is the DIRECTION signal for ST-506 drives and goes high whenever a one is written to register 1E Bit 7.</p> <p>COMMAND This output is the SERIAL COMMAND line for ESDI drives.</p>
29	ENABLE ADDRESS MARK	This signal is required for the ESDI interface. When writing, it causes the ESDI drive to write an address mark on the track. When reading, it causes the ESDI drive to search for an ADDRESS MARK. When the ESDI drive finds an ADDRESS MARK it will activate the ADDRESS MARK FOUND signal at Pin 24. For ESDI drives, WRITE REGISTER 1 should be set to zeros to produce a 3 byte wide ENABLE ADDRESS MARK signal on format writes.
30	WRITE GATE	This signal goes directly to the disk interface and must be HIGH to write data to the disk.
31	WRITE DATA	This signal is the WRITE DATA that goes to the disk drive. This WRITE DATA may be un-encoded or encoded either MFM or RLL and may be either in a pulse format, an NRZ format or NRZI format.
32	WRITE CLOCK	This signal is the code/encoded data rate and is intended for use as a WRITE CLOCK for the ESDI drive interface.
33	READ GATE	This signal indicates that the controller is in an ID for DATA area and is attempting to phase lock onto the READ DATA. This signal is used in the ESDI interface. This signal remains ACTIVE even though the DISK CONTROLLER chip is not actually performing a READ. The BUSY signal (Pin 11) can be used in conjunction with the READ GATE signal to produce a signal enabling an external phase comparator if desired.
34	READ DATA	This signal is the raw DATA pulses that are sent directly from the drive.
35	READ DATA DELAYED	This signal is the same as the READ GATE (Pin 34) with the exception that it is delayed by one half of a READ DATA CYCLE. For example: If you are running MFM data with a code rate of 10 MHZ yielding a READ DATA CYCLE of 100 nanoseconds, then the data on this pin would be DELAYED by one half of the 100 nanoseconds equaling 50 nanoseconds. An external delay line is utilized to produce this READ DATA DELAYED signal.

Pin Description (Continued)

Pin No.	Symbol	Description
36 37	<u>SLOWER</u> and FASTER	These two signals are used as comparison inputs to an external VOLTAGE CONTROLLED OSCILLATOR so that it can produce the PLO signal at Pin 38.
38	PLO/READ CLOCK	The PHASE LOCK OSCILLATOR (PLO) Input is a READ CLOCK signal which is phase locked onto the READ DATA. The rising edge of the PLO clock should occur at the same time as the rising edge of the READ DATA delayed signal at Pin 35. If the DISK CONTROLLER chip is used to control an ESDI interface drive, the input to this pin would be the READ CLOCK signal coming directly from the ESDI interface.
39	XTAL (Crystal)	This is the crystal oscillator input which is the reference clock for writing to the hard disk. The XTAL frequency should be the code frequency going to the disk. For example: If running at MFM with a 5 megabit disk data rate, the MFM code going to the disk would be at a 10 MHz rate and the XTAL input would be at 10 MHz. If using RLL code with a 7 1/2 megabit disk data rate, the code rate going to the disk would be 15 MHz and the XTAL input would be 15 MHz. For ESDI drives, the READ CLOCK would be input at this pin.
40	5 VOLTS	Positive Supply

Register Addresses

Data Lines (D0-D7), in conjunction with the software controlled A0 signal (as an enabling signal), are decoded to select either a write or read operation to be performed

and the REGISTER ADDRESSES to be utilized. (Table 2 is a chart of the A0 REGISTER ADDRESSES)

		Read	Write
		STATUS	REGISTER ADDRESS
A0 = 0	BIT		
	7	CONTROLLER BUSY	AUTO-INCREMENT
	6	DISK OP IN PROGRESS	DISK DATA
	5	WRITE GATE	REG A5
	4	DATA REQUESTED	REG A4
	3	DATA AVAILABLE	REG A3
	2	SEEK COMPLETE	REG A2
	1	TRACK 0	REG A1
	0	ERROR	REG A0
A0 = 1	BIT	DATA	DATA
	7	D7	D7
	6	D6	D6
	5	D5	D5
	4	D4	D4
	3	D3	D3
	2	D2	D2
	1	D1	D1
	0	D0	D0

Table 2. Register Addressing

Auto-Increment

If bit 7 of the REGISTER ADDRESS is set, the address will be automatically incremented after every register read or write.

There are two exceptions to AUTO-INCREMENT: (1) There is no increment after writing the STEP REGISTER (address 9F); and (2) After reading or writing the DATA REGISTER (address C0).

Status Register

The STATUS REGISTER informs the host of certain events performed by the UM83C021 as well as reporting status from the drive control.

Bit	Signal	Description
7	Controller Busy	If bit 7 comes up, this indicates that either a disk read/write is in progress or the controller is still working on the last byte written or it is incrementing the register address.
6	Disk Operation in Progress	If bit 6 comes up, a disk read/write operation is in progress.
5	Write Gate	This bit reflects the state of the WRITE GATE pin from the UM83C021 indicating that the controller is writing to the drive. Normally, registers should not be changed while writing to the disk.
4	Data Request	This bit indicates that the controller requires a byte to be written into the DISK DATA register. It is used for non-DMA data transfers.
3	Data Available	This bit indicates that there is a byte for the host processor to read from the data disk register. It is used for non-DMA data transfers.
2	Track 0/XFR ACK/UTH	This bit reflects the state of its pin (Pin 26) on the UM83C021 (i.e. if the signal at this pin is high, bit 2 will be high). It is used to indicate that the selected drive is at track 0; that an ESDI drive has acknowledged a COMMAND/STATUS transfer; or that a QIC-36 tape drive has detected the upper tape hole.
1	Seek Complete/Status Data/LTH	This bit reflects the state of its pin (Pin 25) on the UM83C021 (i.e. if the signal at this pin is high, bit 1 will be high). It is used to indicate that the selected drive has completed any head positioning sequence; the state of a bit in the CONFIGURATION/STATUS word on an ESDI drive; or that a QIC-36 tape has detected the lower tape hole.
0	Error	This bit is set whenever any bit in the CONTROLLER ERROR register is set. It is the logical OR of the CONTROLLER ERROR register bits and may be used by the host to quickly check successful completion of a command. This bit is reset when a new command is written into the DISK OPERATION register.

Available Registers

There are 64 available REGISTER ADDRESSES in the UM83C021; however, only 41 are used. Table 3 is a list of available WRITE registers and Table 4 is a list of available READ registers.

Register Address Decimal	HEX	Auto Incr HEX	Register
0	00	80	POST-INDEX GAP
1	01	81	ID PLO LOCK-ON
2	02	82	PRE-ID
3	03	83	ID ADDRESS MARK
4	04	84	FE BYTE
5	05	85	ID
6	06	86	ID ECC
7	07	87	POST-ID
8	08	88	DATA READ SKEW
9	09	89	DATA PLO LOCK-ON
10	0A	8A	PRE-DATA
11	0B	8B	DATA ADDRESS MARK
12	0C	8C	F8 BYTE
13	0D	8D	DATA LOW
14	0E	8E	DATA HIGH
15	0F	8F	DATA ECC
16	10	90	POST DATA
17	11	91	INTER-RECORD GAP
18	12	92	SECTORS PER TRACK
19	13	93	ID START LOCATION
20	14	94	ADDRESS MARK FIRST HALF
21	15	95	ADDRESS MARK LAST HALF/UNENCODED ADDRESS MARK
22	16	96	RECORDING CODE
23	17	97	CLOCK DIVIDER
24	18	98	FE
25	19	99	F8
26	1A	9A	SECTOR SIZE
27	1B	9B	SECTOR OPTIONS
28	1C	9C	GAP VALUE
29	1D	9D	
30	1E	9E	DIRECTION
31	1F	9F*	STEP
56	38	B8	CYLINDER HI
57	39	B9	CYLINDER LO
58	3A	BA	HEAD
59	3B	BB	SECTOR
60	3C	BC	TRANSFER COUNT
61	3D	BD	HEAD SELECT
62	3E	BE	DRIVE SELECT
63	3F	BF	DISK OP
64	40	C0*	DATA TO/FROM DISK READ/WRITE

*These Addresses do not Auto-Increment.

Table 3. Write Register Addresses

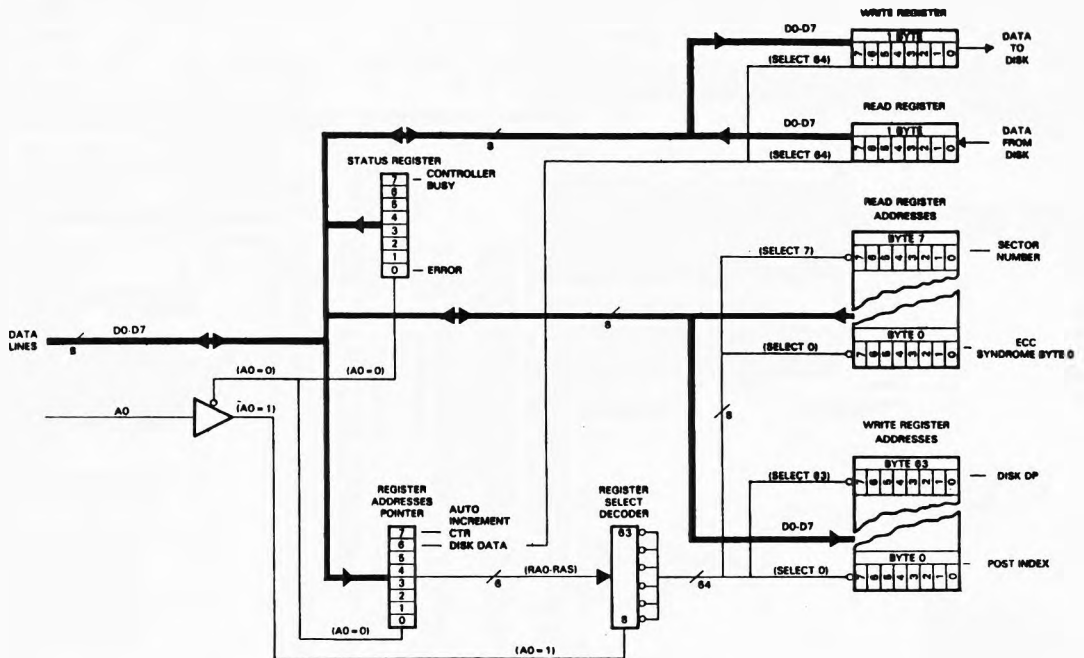

Figure 3. UM83C021 Register Addresses and Selection

Write Register Address Descriptions

The WRITE registers, Hex 0 – 17, control the length of the fields of the track format. To set the length, set the appropriate register with the desired byte count–1.

The following is a description of the available registers within the UM83C021 including the appropriate hex Register Address:

(HEX 00) POST INDEX GAP

Number of bytes after the index pulse.
FIELD LENGTH = 1 – 256 BYTES

(HEX 01) ID PLO LOCK-ON

Read gate starts at the beginning of this field. This field is to allow the PLO to lock onto the read data.
FIELD LENGTH = 1 – 64 BYTES

(HEX 02) PRE-ID

The Address Mark search begins in this field.
FIELD LENGTH = 1 – 64 BYTES

(HEX 03) ID ADDRESS MARK

This field is used on soft sectored media so that the controller can identify the start of ID and DATA fields. ADDRESS MARKS in FM or MFM are recorded with certain clock pulses missing and are unique from all other data and gap bytes recorded on the track. ADDRESS MARKS in RLL use an illegal sequence violating the Encoding scheme of 2 to 7 zeros between flux reversals.
FIELD LENGTH = 1 – 4 BYTES

(HEX 04) FE BYTE

This field is used to identify that you are in an ID field. The value of register 18, field identifier byte, (normally an FE) is expected in this field.
FIELD LENGTH = 1 BYTE (fixed)

(HEX 05) ID

The ID information: CYL-HI, CYL-LO, HEAD and SECTION NUMBER areas are stored in this field.
FIELD LENGTH = 1 – 16 BYTES

(HEX 06) ID ECC

This field contains the CRC or ECC bytes for the ID area.
FIELD LENGTH = 1 – 8 BYTES

(HEX 07) POST-ID

This field should contain 00's. It is required to ensure proper recording and recovery of the last bits of the ID CRC/ECC field. On write data operations, the WRITE GATE goes active at the end of this field.
FIELD LENGTH = 1 – 4 BYTES

(HEX 08) DATA READ SKEW

On READ DATA operations, the READ GATE goes active at the end of this field. This field is intended to allow the PLO to skip over the write splice area before it begins trying to sync onto the read data.
FIELD LENGTH = 1 – 64 BYTES

(HEX 09) DATA PLO LOCK-ON

The READ GATE goes active at this point.
FIELD LENGTH = 1 – 4 BYTES

(HEX 0A) PRE-DATA

The search for ADDRESS MARK starts here.
FIELD LENGTH = 1 – 64 BYTES

(HEX 0B) DATA ADDRESS MARK

See ID ADDRESS MARK
FIELD LENGTH FOR HARD DISK = 1 BYTE
FIELD LENGTH FOR FLOPPY = 3 BYTES

(HEX 0C) F8 BYTE

FIELD LENGTH = 1 BYTE (fixed)

(HEX 0D) DATA LOW
(HEX 0E) DATA HIGH

These two bytes define the length of the DATA FIELD

0D = Low Byte of DATA LENGTH

0E = High Byte of DATA LENGTH

FIELD LENGTH = 1 – 65,536 BYTES

(HEX 0F) DATA ECC

See ID CRC/ECC field.
FIELD LENGTH = 1 – 8 BYTES

(HEX 10) POST DATA

Data WRITES stop at the end of this field.
FIELD LENGTH = 1 – 4 BYTES

(HEX 11) INTER-RECORD GAP

This field provides a separation between each sector to allow speed tolerances; write to read recovery time (time between deassertion of WRITE GATE and assertion of READ GATE) head switching time and controller decision making time between sectors and variations in detecting INDEX and SECTOR.
FIELD LENGTH = 1 – 256 BYTES

(HEX 12) SECTORS PER TRACK

Write N-1 to this register
FIELD LENGTH = 1 – 256 BYTES

(HEX 13) ID START LOCATION

This register is set to specify which internal register follows the FE register in the ID field. This register is set as shown below.

ID Start Value	Next Byte Following FE	
00	FE	(causes FE to be used twice)
01	CYLINDER HI	(normal setting for hard disk)
02	CYLINDER LO	(normal setting for floppy)
03	HEAD	
04	SECTOR	
05	SECTOR SIZE	

(HEX 14) ADDRESS MARK FIRST HALF
(HEX 15) ADDRESS MARK SECOND HALF

HEX 14 = The first half of the encoded ADDRESS MARK
HEX 15 = The second half of the encoded ADDRESS MARK or the whole unencoded ADDRESS MARK when running in unencoded mode.

ADDRESS MARKS are special bytes recorded at the beginning of each ID and DATA field. These bytes are unique and do not occur anywhere else on the disk. They are used to identify the exact beginning of the ID and DATA fields. These ADDRESS MARKS are made unique by violating the rules for encoding the data.

When using MFM encoding, the ADDRESS MARK is an A1 data byte with one of the clock bits dropped.

```
MFM  CLOCK BITS  0 0 0 0  1 1 1 0
      DATA BITS  1 0 1 0  0 0 0 1
```

MFM ADDRESS MARK

01010100 10001001 = HEX 54 and HEX 89

└ This bit has been dropped

HEX 54 = First half in location HEX 14

HEX 89 = Second half in location HEX 15

When using UM83C021 RLL encoding, the ADDRESS MARK is a 4B data byte with one of the bits dropped. This results in a unique pattern with 8 zeros in a row.

In 2,7 RLL encoding, the maximum number of zeros in a row is 7.

```

                4B      010   010   11
RLL CODE FOR 4B      000100 000100 1000
RLL ADDRESS MARK    000100 000000 1000 = HEX 10 and HEX 08
    
```

↓
This bit has been dropped

HEX 10 = First half in location HEX 14
HEX 08 = Second half in location HEX 15

(HEX 16) RECORDING CODE

80	00	NRZ WRITE DATA
40	01	NRZI WRITE DATA
	10	PULSE WRITE DATA
	11	
20	00	NRZ READ DATA
10	01	NRZI READ DATA
	10	PULSE READ DATA
	11	
08	000	UNENCODED
04	001	FM
02	010	MFM
	011	RLL 2,7
01		Should be 0

If additional bytes are written to or read from the chip during this synchronization, the results will be unpredictable.

When using a divided down clock, the length of time required for this synchronization may become significant. For example: when working with a 5-1/4 inch floppy, the disk clock would be 2 microseconds. The synchronization could take up to $5 \times 2 = 10$ microseconds. When designing your system, insure that reads and writes to the UM83C021 are always farther apart than 10 microseconds whenever the clock is divided down to a 2 microsecond period. This can be done by inserting extra instructions in the host program or by monitoring the CONTROLLER BUSY bit.

(HEX 17) CLOCK DIVIDER

Through the use of a PLO divider circuit, the disk controller chip is capable of controlling several devices that do not operate at the same data rates without requiring a separate PLO circuit for each. For example, the controller can operate a hard disk, a floppy disk, and a tape drive using only a single PLO running at 10 MHz or 15 MHz. If running a 15 MHz PLO for an RLL encoded hard disk, the controller is divided by 15 to run the tape drive and divided by 30 to run the floppy disk.

(HEX 18) FE

ID field identifier byte
Write FE to this register.

The PLO divider can divide from 1 to 256. To divide by a number n , the number $n-1$ must be written into the Clock Divider at register address 17 hexadecimal.

(HEX 19) F8

Data field identifier byte.
Write F8 to this register for hard disk or FB for floppies.

In order to improve PLO lock-on performance, the Clock Divider is synchronized to the first data pulse at the beginning of every read operation.

(HEX 1A) SECTOR SIZE

This byte follows the sector number in the ID field and is normally used with floppies – not with a hard disk.

Bytes that are written to or read from the UM83C021 at RAM CLOCK speed are internally synchronized to the WRITE CLOCK. This synchronization can take up to 5 write clock cycles. During this synchronization, the CONTROLLER BUSY bit (Status Register bit 7) will be one.

(HEX 1B) SECTOR OPTIONS

The UM83C021 handles soft or hard sectored disks or ESDI disks using ESDI Address Marks. ESDI byte clock operation requires an external counter to create hard sector pulses.

```

BIT 7 to 2 = 0
BIT 1      = 02   00 SOFT SECTORED
BIT 0      = 01   01 HARD SECTORED
                10 ESDI ADDRESS MARKS
                11 ESDI BYTE CLOCKS
    
```

(HEX 1C) GAP VALUE

Write 4E for MFM encoding
Write 33 for RLL encoding

(HEX 1E) DIRECTION

Bit 7 of the register is sent directly to the DIRECTION output pin. Writing a HEX 80 to this address will make the pin high; a HEX 00 will make it low. This pin is used for direction control of ST506 drives or for command data on ESDI drives.

(HEX 1F) STEP

Bit 0 of this register is sent directly to the STEP output pin. Writing a HEX 01 to this address will make the pin high; a HEX 00 will make it low. This pin is used for STEP CONTROL of ST506 drives or for TRANSFER REQUEST on ESDI drives. Auto-increment is disabled for this address because it must be written repetitively to create multiple STEP pulses at the drive interface.

(HEX 38) CYLINDER HI

This register contains the HI 8 bits of the cylinder number. The contents of this register and the next 3 registers are used for writing or searching for ID FIELDS on the disk.

(HEX 39) CYLINDER LO

This register contains the LO 8 bits of the cylinder number.

(HEX 3A) HEAD

This register contains the HEAD number.

(HEX 3B) SECTOR

This register contains the SECTOR number. On multi-sector operations, this register is incremented after each sector is read or written and may be read at address 07.

(HEX 3C) TRANSFER COUNT

This register contains the number of sectors desired for this command -1. On multi-sector operations, this register is decremented after each sector is read or written and may be read at address 06.

(HEX 3D) HEAD SELECT

When this register is written, the external SET HEAD pin strobes low to latch the head number from the data bus.

(HEX 3E) DRIVE SELECT

When this register is written, the external SET DRIVE pin STROBES low so that the external drive register can latch the drive number from the data bus.

(HEX 3F) DISK OP

Writing to this register starts or stops DISK READ or WRITE operations. The commands are listed below and are described in more detail in the DISK COMMAND section.

00 STOP DISK OPERATION
80 NO-OP

81 WRITE DATA
82 READ DATA
83 READ ID
84 WRITE FIRST SECTOR
85 WRITE NEXT SECTOR
86 FORMAT WRITE INTERLEAVED
87 FORMAT WRITE SEQUENTIAL
88 READ DATA IMMEDIATE
89 WRITE SECTOR IMMEDIATE
8A WRITE GAP IMMEDIATE
8B VERIFY DATA
8C READ LONG
8D WRITE LONG
8E COMPUTE ERROR SHORT, CORRECTION SPAN 5, 11 BITS
8F COMPUTE ERROR LONG, CORRECTION SPAN 11, 22 BITS

(HEX 40) DATA TO/FROM DISK

Data written to this register is serialized and sent as data to the disk. Writing to this register resets the DATA REQUESTED status bit (Bit 4). If data is not written fast enough to keep up with the disk, the OVERRUN/UNDERRUN status bit (register 05 Bit 1) will be set.

Read Register Address Descriptions

Register Address	Decimal	Hex	Auto Inch Hex	Register
	0	00	80	Not used
	1	01	81	Not used
	2	02	82	Not used
	3	03	83	Not used
	4	04	84	Disk status
	5	05	85	Controller status
	6	06	86	Transfer count
	7	07	87	Sector number

Register Address	Decimal	Hex	ECC 56 Bit	ECC 32 Bit	CRC 16 Bits
	8	08	88	Not used	Not used
	9	09	89	0	Not used
	10	0A	8A	1	Not used
	11	0B	8B	2	Not used
	12	0C	8C	3	0
	13	0D	8D	4	1
	14	0E	8E	5	2
	15	0F	8F	6	3

64 40 C0 * Data from disk

* This address does not auto-increment

Table 4. Read Register Addresses
(HEX00 – HEX03) NOT USED
(HEX04) DISK STATUS

BIT 7 = DRIVE SELECTED/STATUS 1 (HEX 80)

This bit has a dual role when controlling a Winchester drive. It indicates that a drive has been successfully selected. This pin directly reads the logic level of pin 27 on the chip.

BIT 6 = READY/STATUS 0 (HEX 40)

This bit also has a dual role. When controlling floppy and Winchester drives, it indicates that a drive is up to speed and ready for read or write. This pin directly reads the logic level of pin 21 on the chip.

BIT 5 = SECTOR ADDRESS MATCH (HEX 20)

This bit is set when a sector ID matches what was set into the Sector Address Registers during a read/write operation.

BIT 4 = LAST SECTOR ON TRACK (HEX 10)

This bit is set during the last sector of a track. (Sector # in ID field = Sector per track.) See Multi-Sector transfers.

BITS 3 THRU 0 = FIELD COUNTER

The FIELD COUNTER indicates what field is passing under the heads on a read or write.

FIELD COUNT	HEX COUNT	FIELD LOCATION ON DISK
0	00	INTER-RECORD GAP or POST-INDEX GAP
1	01	ID PLO LOCK-ON
2	02	PRE-ID
3	03	ID AM
4	04	FE
5	05	ID
6	06	ID ECC
7	07	POST-ID
8	08	DATA READ SKEW
9	09	DATA PLO LOCK-ON
10	0A	PRE-DATA
11	0B	DATA AM
12	0C	F8
13	0D	DATA
14	0E	DATA ECC
15	0F	POST-DATA

(HEX 05) CONTROLLER STATUS
BIT 7 = NO RECORD FOUND (HEX 80)

Indicates that on a read or write, the controller has received two successive index pulses without finding an ID field that matched the Sector Address registers. Sector pulses are not input on the INDEX pin).

BIT 6 = MISSING DATA AM (F8 MISCOMPARE) (HEX 40)

This bit is set if the byte after the Data Address Mark does not match the contents of register 19, the Data Field Identifier byte, indicating that a data field probably does not exist.

BIT 5 = ID ECC/CRC ERROR (HEX 20)

When set indicates that a read/write sector to the addressed sector was found, but that the CRC/ECC was in error.

BIT 4 = DATA ECC ERROR (HEX 10)

When set indicates that a read of the addressed sector was found, but that the DATA field CRC/ECC bytes was in error.

BIT 3 = DATA MISMATCH (HEX 08)

Indicates that the Verify command has stopped with a data mismatch error. See Verify command.

BIT 2 = DATA TRANSFER STOPPED (STOP RECEIVED) (HEX 04)

Indicates that during a read or write the DMA-STOP pin was activated and that the transfer has stopped.

BIT 1 = OVERRUN/UNDERRUN (HEX 02)

Indicates that data was not transferred to or from the controller quick enough for the Serializer/Deserializer section.

BIT 0 = NOT USED
(HEX 06) TRANSFER COUNT

This register contains the number of sectors remaining (including the current) for Multi-sector operations and it is decremented after each successful sector read or write.

(HEX 07) SECTOR NUMBER

This register contains the SECTOR NUMBER for the operation that the controller is currently performing. It is incremented after each multi-sector operation but is not incremented if an error occurs.

(HEX 08) NOT USED
(HEX 09) 56 BIT ECC SYNDROME BYTE 0
(HEX 0A) 56 BIT ECC SYNDROME BYTE 1
(HEX 0B) 56 BIT ECC SYNDROME BYTE 2
(HEX 0C) 56 BIT ECC SYNDROME BYTE 3
(HEX 0D) 56 BIT ECC SYNDROME BYTE 4
(HEX 0E) 56 BIT ECC SYNDROME BYTE 5
Disk Commands

Writing to the COMMAND register at location 3F causes a disk operation to begin. All registers used in the disk operation should be set up prior to writing to the COMMAND register.

(HEX 00) ABORT

This command will immediately terminate any operation in progress.

(HEX 80) NO OP

This command causes no disk operation.

(HEX 81) WRITE DATA

This command writes data from memory into the data field of the sector whose address has been written into the sector address registers in the chip. Multi-sector writes are possible up to 256 sectors.

(HEX 82) READ DATA

This command reads the data field from the sector whose ID has been set into the registers on the disk controller. The data field is transferred to memory by DMA. It may optionally be transferred under program control if the disk speed is slow enough for the computer to keep up with it. The F8 byte immediately following the data address mark is not transferred but is checked to assure that a data field is present.

At the end of every sector transfer, the Transfer Count is checked. If it is zero, the operation stops. If it is non-zero, it is decremented, the sector number is incremented, and the next sector is read. This process continues until the Transfer Count goes to zero, the end of the track is reached, or an error occurs.

The DMA data transfer may be stopped by having STOP go low during a DMA cycle (ACK low). If this happens, the disk controller will immediately cease data transfer and will halt the operation at the end of the current sector. In this case, the Transfer Count will not be decremented and the sector number will not be incremented.

The residual Transfer Count and the sector number registers can be read to determine where to continue.

(HEX 83) READ ID

This command reads the next ID fields and ID ECC fields that are encountered on the disk or tape. It transfers both fields to memory. The ID ECC field is checked for errors.

It can be used to establish track orientation on tape or disk. It can also be used in error recovery procedures to determine if the read-write heads are positioned over the correct track.

(HEX 84) WRITE FIRST SECTOR

This command begins writing at the Index Pulse and writes both ID fields and data fields. Information for the index field comes from the internal sector address registers. Information for the data fields is transferred from memory.

Multi-sector writes can write up to 256 sectors.

If this command is terminated by the transfer count going to zero, it stops writing at the end of the post-data field of the last sector. If this command is terminated by the sectors per track counter going to zero, it will continue writing the postdata field until the next Index Pulse is reached or until a Reset Command (00 hexadecimal) is received.

This command can be used to format and write data to a track in a single operation.

(HEX 85) WRITE NEXT SECTOR

This command begins writing at the end of the post-data field of the sector whose address has been set into the internal sector address registers. It writes ID fields as well as data fields. It stops writing at the end of the post-data field when the transfer count goes to zero.

Multi-sector writes can be done up to 256 sectors.

This command can be used to repair the ID field of a damaged sector.

(HEX 86) FORMAT INTERLEAVED

This command is similar to the Format Sequential (See HEX 87) command. However, in this command the ID fields to be written on the disk come from memory rather than from the internal registers on the ID Numbers written are totally programmable and can be interleaved in any manner desired.

For each sector written the disk controller will fetch all bytes of the ID field plus one byte of filler (usually a hexadecimal E5) for the data field. The hexadecimal FE byte immediately following the ID Address Mark is not fetched from memory but is written from the internal register in the disk controller.

For a typical hard disk format the ID field length would be 4, and the following 5 bytes would be fetched from memory for each sector.

Cylinder High
Cylinder Low
Head
Sector
Data Filler Byte (usually E5)

If the track is being formatted with 26 sectors, then a total of $5 \times 26 = 130$ bytes will be fetched from memory during the Format Interleaved command execution.

(HEX 87) FORMAT SEQUENTIAL

This command is used to format a single track on a disk. It begins writing at index and continues writing to the next index. It writes all ID and data fields using the information set into the on-chip ID and DATA registers.

ID Byte	Register Address	Data Filler Byte	Register Address
CYLINDER HI	HEX 38	DATA	HEX 40
CYLINDER LO	HEX 39		
HEAD	HEX 3A		
SECTOR SIZE	HEX 1A		

After each sector is written, the sector number register is incremented by one and the track size register is decremented by one. When the track size register reaches zero, one last sector is written and the remainder of the track is written with zero.

No data is transferred to or from memory during a format sequential command.

(HEX 88) READ DATA IMMEDIATE

It differs in that when it is issued, the track orientation counters are reset to the post-index gap and the read operation begins there. It is intended primarily for use when controlling tape drives where there is no index pulse to establish position on the track. With this command the microprocessor is responsible for maintaining track orientation.

Data transfer occurs the same as with the Read Data command. Up to 256 sectors can be transferred with a single command.

(HEX 89) WRITE IMMEDIATE

Write Immediate is a formatting type write in that it writes the ID field of each sector as well as the data field. It is intended primarily for use when controlling tape where there is no index pulse to establish track orientation. When it is issued, the track orientation counters are set to post-index gap and WRITE GATE goes high immediately.

ID field information is written from the internal sector address registers. Data field information is transferred from memory. The sector number is incremented after every sector is written. Up to 256 sectors can be written with a single Write Immediate command.

Writing stops at the end of the post-data field when the transfer count goes to zero.

If Write Immediate is terminated by the physical sector count going to zero, the controller will continue writing the post-data field until it is stopped by the microprocessor issuing a Reset Command (00 hexadecimal) or until an Index Pulse is received. This allows tapes to be

written with a long trailer gap after the last data block.

(HEX 8A) WRITE GAP IMMEDIATE

When the Write Gap command is issued, the track orientation counters are set to post-index gap and the controller immediately begins writing zeroes. Writing continues until index is reached or until this command is terminated by issuing another command or a halt command.

This command is intended primarily for writing header or trailer zero fields on tape.

(HEX 8B) VERIFY DATA

This command begins reading data from the disk at the addressed sector and comparing it to the data transferred from memory. If the disk data and the data from memory do not match, this command will terminate with the Data Mismatch bit set (Read Register 0D bit 3).

(HEX 8C) READ LONG

This command is used primarily for checking the ECC and CRC circuitry. It reads and transfers to memory the data field and data ECC field of the addressed sector.

The ID ECC field and the data ECC field are checked and error latches are set if they are not correct. An error in the ID ECC field will not stop the data field from being transferred as it would with the Read Data command. However, an error in either ECC field will terminate a multi-sector Read Long at the end of the post-data field of the sector containing the error.

After using the Read Long command, the ECC Syndrome registers containing the EGG bits read from the disk instead of error bits.

This command also allows the reading of records that were written by controllers that use different ECC or CRC generators.

(HEX 8D) WRITE LONG

This command is used primarily for checking the ECC and CRC circuitry. It writes from memory the data field and the data ECC field of the addressed sector. This command permits the creation of errors to assist in testing the error detection circuits.

An error in the ID ECC field will not prevent writing to the addressed sector.

(HEX 8E) COMPUTE ERROR

This command is used to compute ECC error. It's correction span is 5 & 11 bits for 32 & 56 bits ECC.

(HEX 8F) COMPUTE ERROR LONG

This command is used to compute ECC error. It's correction span is 11 and 22 bits for 32 and 56 bits ECC.

Timing Specs and Diagrams

This section is devoted to the timing of signals and their relationship to each other in order to make the maximum use of the UM83C021. The following tables and diagrams

are to be used as design tools when incorporating the UM83C021 into your system.

Signal	Min.	Typ.	Max.	Units
XTAL		20		MHZ
PLO		20		MHZ
READ DATA		10		MBITS/SEC

Table 5. Signal Frequencies

Signal	LO	HI	Units
XTAL	13	20	NANOSECONDS
PLO	13	20	
MCLK	30	30	
RESET	100		

Table 6 Signal Widths

Delays From	To	Min.	Typ.	Max.	Units
XTAL HI	WRITE DATA		35	70	NANOSECONDS
XTAL	WRITE CLOCK		30	60	
XTAL OR PLO HI	REQUEST LO		32	63	
ACK & MCLK LO	REQUEST HI		36	72	
MCLK LO	SET HEAD LO		30	59	
MCLK HI	SET HEAD HI		21	42	
MCLK LO	SET DRIVE LO		30	59	
MCLK HI	SET DRIVE HI		21	42	
XTAL OR PLO HI	DIRECTION		43	85	
XTAL OR PLO HI	STEP		38	77	
CSEL HI OR WRT LO	D0-D7 TRI-STATE		25	50	
CSEL LO & WRT HI	D0-D7 ACTIVE		29	57	
ACK HI OR WRT LO	D0-D7 TRI-STATE		31	61	
ACK LO & WRT HI	D0-D7 ACTIVE		29	57	
XTAL HI	WRGT		32	63	
PLO HI	RDGT		36	71	
XTAL OR PLO HI	ENAM		36	71	
XTAL OR PLO HI	BUSY		31	62	
RDEL HI	FSTR HI		26	51	
PLO HI	FSTR LO		26	51	
PLO HI	SLWR LO		26	51	
RDEL HI	SLWR HI		26	51	

Table 7. Delays

From Changing Signal	Set-Up	To	Hold	Units
ACKNOWLEDGE ACKNOWLEDGE	4.0	RAMCLK LO RAMCLK HI	0	NANOSECONDS
WRITE WRITE	15	RAMCLK LO RAMCLK HI	15	
CHIP SELECT CHIP SELECT	15	RAMCLK LO RAMCLK HI	15	
A0 A0	15	RAMCLK LO RAMCLK HI	15	
NOTE THAT ALL THE ABOVE SIGNALS SHOULD CHANGE WHEN RAMCLK IS HIGH AND BE STABLE WHEN RAMCLK IS LOW				
DATA (D0 – D7) STOP	2 6	RAMCLK HI RAMCLK HI	12 3	NANOSECONDS

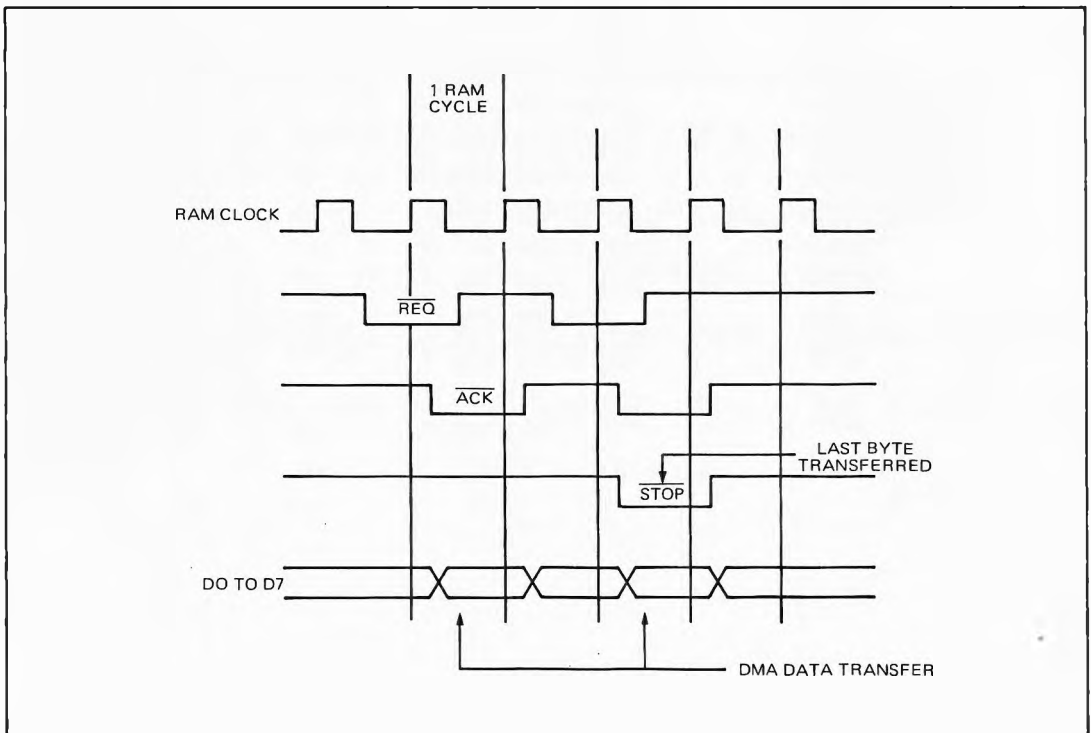
Table 8. Set Up and Hold Time

Figure 4. DMA Data Transfer Cycles

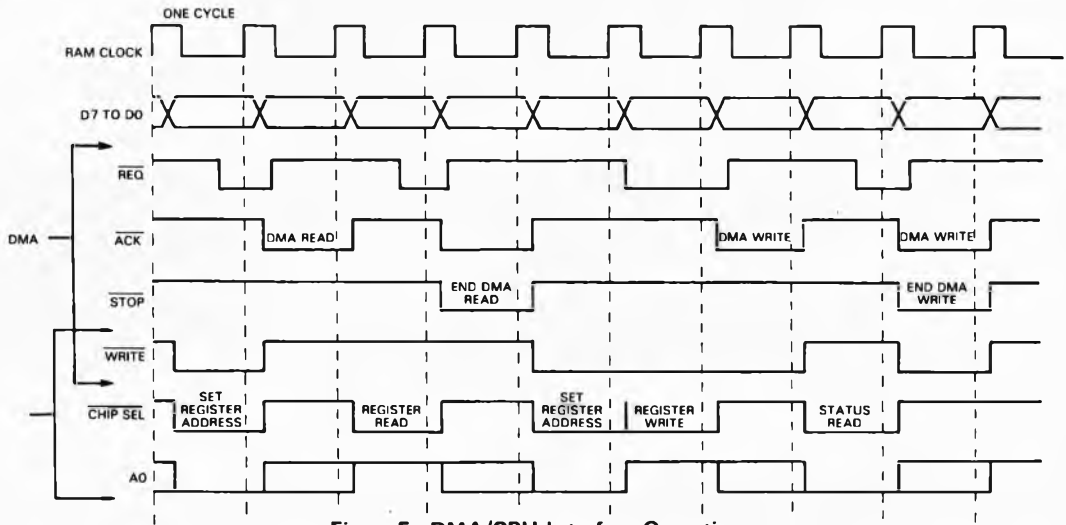

Figure 5. DMA/CPU Interface Operation