



UM8237AE/-4/-5

Programmable DMA Controller (DMAC)

Features

- Enable/Disable Control of Individual DMA Requests
- Four Independent DMA Channels
- Independent Autoinitialization of all Channels
- Memory-to-Memory Transfers
- Memory Block Initialization
- Single 5V power supply
- High performance: Transfers up to 1.6M Bytes/Second with 5 MHz UM8237AE-5
- Directly Expandable to any Number of Channels
- End of Process Input for Terminating Transfers
- Software DMA Requests
- Independent Polarity Control for DREQ and DACK Signals

General Description

The UM8237AE/-4/-5 Direct Memory Access Controller (DMAC) is a peripheral interface circuit for micro-processor systems. It is designed to improve system performance by allowing external devices to directly transfer information from the system memory. Memory-to-memory transfer capability is also provided. The UM8237AE/-4/-5 offers a wide variety of programmable

control features to enhance data throughput and system optimization and to allow dynamic reconfiguration under program control.

UM8237AE/-4/-5 is fabricated in Si-Gate NMOS process, with each channel having a full 64K address and word count capability.

Pin Configuration

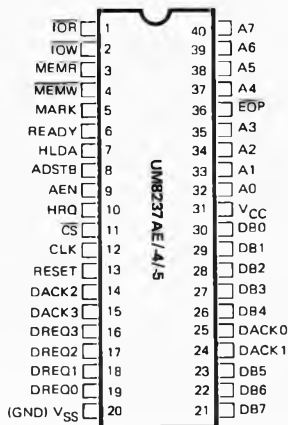

Block Diagram

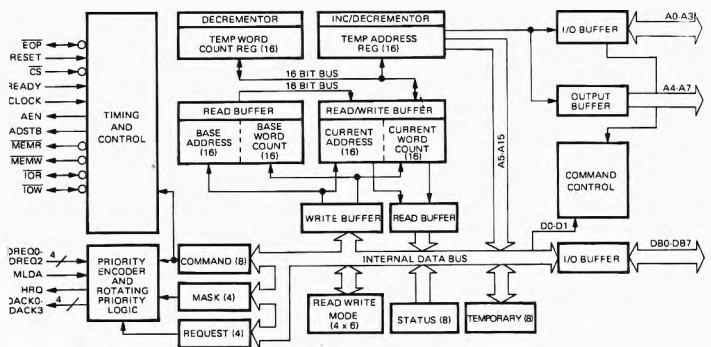

Absolute Maximum Ratings*

Ambient Temperature under Bias 0°C to 70°C
 Storage Temperature -65°C to + 150°C
 Voltage on any Pin with Respect
 to Ground -0.5 to 7V
 Power Dissipation 1.5 Watt

***Comments**

Stresses above those listed under "Absolute Maximum Ratings" may cause permanent damage to the device. These are stress ratings only. Functional operation of this device at these or any other conditions above those indicated in the operational sections of this specification is not implied and exposure to absolute maximum rating conditions for extended periods may affect device reliability.

D.C. Electrical Characteristics ($T_A = 0^\circ\text{C}$ to 70°C , $V_{CC} = 5.0\text{V} \pm 5\%$, $V_{SS} = 0\text{V}$)

Symbol	Parameter	Min.	Typ.(1)	Max.	Unit	Test Conditions
V _{OH}	Output HIGH Voltage	2.4			V	I _{OH} = -200 μ A
		3.3			V	I _{OH} = -100 μ A (HRQ Only)
V _{OL}	Output LOW Voltage			0.45	V	I _{OL} = 2.0 mA (data bus) I _{OL} = 3.2 mA (other outputs)
V _{IH}	Input HIGH Voltage	2.0		V _{CC} + 0.5	V	
V _{IL}	Input LOW Voltage	-0.5		0.8	V	
I _{LI}	Input Load Current			± 10	μ A	0V \leq V _{IN} \leq V _{CC}
I _{LO}	Output Leakage Current			± 10	μ A	0.45V \leq V _{OUT} \leq V _{CC}
I _{CC}	V _{CC} Supply Current		65	130	mA	T _A = +25°C
			75	150	mA	T _A = 0°C
C _O	Output Capacitance		4	8	pF	fc = 1.0 MHz, Inputs = 0V
C _I	Input Capacitance		8	15	pF	
C _{I/O}	I/O Capacitance		10	18	pF	

NOTES:

1. Typical values are for T_A = 25°C, nominal supply voltage and nominal processing parameters.
2. Input timing parameters assume transition times of 20 ns or less. Waveform measurement points for both input and output signals are 2.0V for HIGH and 0.8V for LOW, unless otherwise noted.
3. Output loading is 1 TTL gate plus 50 pF capacitance, unless otherwise noted.
4. The net I_{OH} or MEMW Pulse width for normal write will be TCY-100 ns and for extended write will be 2TCY-100 ns. The net I_{OR} or MEMR pulse width for normal read will be 2TCY-50 ns and for compressed read will be TCY-50 ns.
5. TDQ2 is specified for two different output HIGH levels. TDQ1 is measured at 2.0V. TDQ2 is measured at 3.3V. The value for TDQ2 assumes an external 3.3 k Ω pull-up resistor connected from HRQ to V_{CC}.
6. DREQ should be held active until DACK is returned.
7. DREQ and DACK signals may be active high or active low. Timing diagrams assume the active high mode.
8. Output loading on the data bus is 1 TTL gate plus 100 pF capacitance.
9. Successive read and/or write operations by the external processor to program or examine the controller must be timed to allow at least 600 ns for the UM8237AE at least 500 ns for the UM8237AE-4 and at least 400 ns for the UM8237AE-5, as recovery time between active read or write pulses.
10. Parameters are listed in alphabetical order.
11. Pin 5 is an input that should always be at a logic high level. An internal pull-up resistor will establish a logic high when the pin is left floating. Alternatively, pin 5 may be tied to V_{CC}.

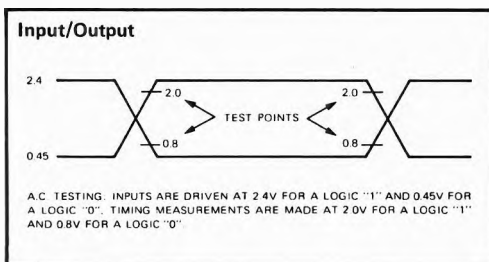
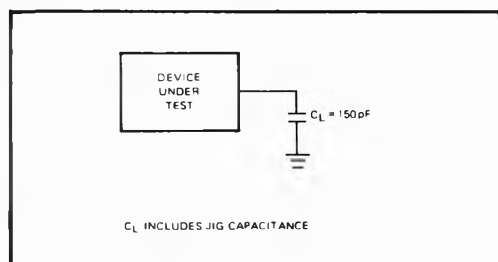
A.C. Testing Input, Output Waveform

A.C. Testing Load Circuit

A.C. Characteristics –DMA (Master) Mode
 $(T_A = 0^{\circ}\text{C to } 70^{\circ}\text{C}, V_{CC} = +5\text{V} \pm 5\%, V_{SS} = 0\text{V})$

Symbol	Parameter	8237AE		8237AE-4		8237AE-5		Unit
		Min.	Max.	Min.	Max.	Min.	Max.	
TAEL	AEN HIGH from CLK LOW (S1) Delay Time		300		225		200	ns
TAET	AEN LOW from CLK HIGH (S1) Delay Time		200		150		130	ns
TAFAB	ADR Active to Float Delay from CLK HIGH		150		120		90	ns
T AFC	$\overline{\text{READ}}$ or $\overline{\text{WRITE}}$ Float from CLK HIGH		150		120		120	ns
TAFDB	DB Active to Float Delay from CLK HIGH		250		190		170	ns
TAHR	ADR from $\overline{\text{READ}}$ HIGH Hold Time	TCY-100		TCY-100		TCY-100		ns
TAHS	DB from ADSTB LOW Hold Time	50		40		30		ns
TAHW	ADR from $\overline{\text{WRITE}}$ HIGH Hold Time	TCY-50		TCY-50		TCY-50		ns
TAK	DACK Valid from CLK LOW Delay Time (Note 7)		250		220		170	ns
	$\overline{\text{EOP}}$ HIGH from CLK HIGH Delay Time		250		190		170	ns
	$\overline{\text{EOP}}$ LOW to CLK HIGH Delay Time		250		190		100	ns
TASM	ADR Stable from CLK HIGH		250		190		170	ns
TASS	DB to ADSTB LOW Setup Time	100		100		100		ns
TCH	Clock HIGH Time (Transitions ≤ 10 ns)	120		100		80		ns
TCL	Clock LOW Time (Transitions ≤ 10 ns)	150		110		68		ns
TCY	CLK Cycle Time	320		250		200		ns
TDCL	CLK HIGH to $\overline{\text{READ}}$ or $\overline{\text{WRITE}}$ LOW Delay (Note 4)		270		200		190	ns
TDCTR	$\overline{\text{READ}}$ HIGH from CLK HIGH (S4) Delay Time (Note 4)		270		210		190	ns
TDCTW	$\overline{\text{WRITE}}$ HIGH from CLK HIGH (S4) Delay Time (Note 4)		200		150		130	ns
TDQ1	HRQ Valid from CLK HIGH Delay Time (Note 5)		160		120		120	ns
TDQ2			250		190		120	ns
TEPS	$\overline{\text{EOP}}$ LOW from CLK LOW Setup Time	60		45		40		ns
TEPW	$\overline{\text{EOP}}$ Pulse Width	300		225		220		ns
TFAAB	ADR Float to Active Delay from CLK HIGH		250		190		170	ns
TFAC	$\overline{\text{READ}}$ or $\overline{\text{WRITE}}$ Active from CLK HIGH		200		150		150	ns
TFADB	DB Float to Active Delay from CLK HIGH		300		225		200	ns
THS	HLDA Valid to CLK HIGH Setup Time	100		75		75		ns
TIDH	Input Data from $\overline{\text{MEMR}}$ HIGH Hold Time	0		0		0		ns
TIDS	Input Data to $\overline{\text{MEMR}}$ HIGH Setup Time	250		190		170		ns
TODH	Output Data from $\overline{\text{MEMW}}$ HIGH Hold Time	20		20		10		ns
TODV	Output Data Valid to $\overline{\text{MEMW}}$ HIGH	200		125		125		ns
TQS	DREQ to CLK LOW (S1, S4) Setup Time (Note 7)	0		0		0		ns
TRH	CLK to READY LOW Hold Time	20		20		20		ns
TRS	READY to CLK LOW Setup Time	100		60		60		ns
TSTL	ADSTB HIGH from CLK HIGH Delay Time		200		150		130	ns
TSTT	ADSTB LOW from CLK HIGH Delay Time		140		110		90	ns

A.C. Characteristics—Peripheral (Slave) Mode
 $(T_A = 0^\circ\text{C to } 70^\circ\text{C}, V_{CC} = 5.0\text{V} \pm 5\%, V_{SS} = 0\text{V})$

Symbol	Parameter	8237AE		8237AE-4		8237AE-5		Unit
		Min.	Max.	Min.	Max.	Min.	Max.	
TAR	ADR Valid or CS LOW to READ LOW	50		50		50		ns
TAW	ADR Valid to WRITE HIGH Setup Time	200		150		150		ns
TCW	CS LOW to WRITE HIGH Setup Time	200		150		150		ns
TDW	Data Valid to WRITE HIGH Setup Time	200		150		150		ns
TRA	ADR or CS Hold from READ HIGH	0		0		0		ns
TRDE	Data Access from READ LOW (note B)		200		200		140	ns
TRDF	DB Float Delay from READ HIGH	20	100	20	100	0	70	ns
TRSTD	Power Supply HIGH to RESET LOW Setup Time	500		500		500		ns
TRSTS	RESET to First TOWR	2TCY		2TCY		2TCY		ns
TRSTW	RESET Pulse Width	300		300		300		ns
TRW	READ Width	300		250		200		ns
TWA	ADR from WRITE HIGH Hold Time	20		20		20		ns
TWC	CS HIGH from WRITE HIGH Hold Time	20		20		20		ns
TWD	Data from WRITE HIGH Hold Time	30		30		30		ns
TWW5	Write Width	200		200		160		ns

Pin Description

Pin No.	Symbol	I/O	Description
31	V_{CC}		+5 volt supply.
20	V_{SS}		Ground.
12	CLK	I	Clock input controls the internal operations of the UM8237AE/-4/-5 and its rate of data transfer. The input may be driven at up to 5 MHz for the UM8237AE/-4/-5.
11	\overline{CS}	I	Chip Select is an active low input used to select the UM8237AE/-4/-5 as an I/O device during the Idle cycle. This allows CPU communication on the data bus.
13	RESET	I	Reset is an active high input which clears the Command, Status, Request and Temporary registers. It also clears the first/last flip-flop and sets the Mask register. Following a Reset the device is in the Idle cycle.
6	READY	I	Ready is an input used to extend the memory read and write pulses from the UM8237AE/-4/-5 to accommodate slow memories or I/O peripheral devices. Ready must not make transitions during its specified setup/hold time.
7	HLDA	I	The active high Hold Acknowledge from the CPU indicates that it has relinquished control of the system busses.
5	MARK	I	This pin has no use for the UM8237AE/-4/-5, but should always be tied high.
19, 18 17, 16	DREQ0-DREQ3	I	The DMA Request lines are individual asynchronous channel request inputs used by peripheral circuits to obtain DMA service. In fixed Priority, DREQ0 has the highest priority and DREQ3 has the lowest priority. A request is generated by activating the DREQ line of a channel. DACK will acknowledge the recognition of a DREQ signal. Polarity of DREQ is programmable. Reset initializes these lines to active high. DREQ must be maintained until the corresponding DACK goes active.

Pin Description (Continued)

Pin No.	Symbol	I/O	Description
30 ~ 26 23 ~ 21	DB0-DB7	I/O	The Data Bus lines are bidirectional three-state signals connected to the system data bus. The outputs are enabled in the Program condition during the I/O Read to output the contents of an Address register, a Status register, the Temporary register or a Word Count register to the CPU. The outputs are disabled and the inputs are read during and I/O Write cycle when the CPU is programming the UM8237AE/-4/-5 control registers. During DMA cycles the most significant 8 bits of the address are output onto the data bus to be strobed into an external latch by ADSTB. In memory-to-memory operations, data from the memory comes into the UM8237AE/-4/-5 on the data bus during the read-from-memory transfer. In the write-to-memory transfer, the data bus outputs place the data into the new memory location.
1	$\overline{\text{TOR}}$	I/O	I/O Read is a bidirectional active low three-state line. In the Idle cycle, it is an input control signal used by the CPU to read the control registers. In the Active cycle, it is an output control signal used by the UM8237AE/-4/-5 to access data from a peripheral during a DMA Write transfer.
2	$\overline{\text{TOW}}$	I/O	I/O Write is a bidirectional active low three-state line. In the Idle cycle, it is an input control signal used by the CPU to load information into the UM8237AE/-4/-5. In the Active cycle, it is an output control signal used by the UM8237AE/-4/-5 to load data to the peripheral during a DMA Read transfer.
36	$\overline{\text{EOP}}$	I/O	End of Process is an active low bidirectional signal. Information concerning the completion of DMA services is available at the bidirectional $\overline{\text{EOP}}$ pin. The UM8237AE/-4/-5 allows an external signal to terminate an active DMA service. This is accomplished by pulling the $\overline{\text{EOP}}$ input low with an external $\overline{\text{EOP}}$ signal. The UM8237AE/-4/-5 also generates a pulse when the terminal count (TC) for any channel is reached. This generates an $\overline{\text{EOP}}$ signal which is output through the $\overline{\text{EOP}}$ Line. The reception of $\overline{\text{EOP}}$, either internal or external, will cause the UM8237AE/-4/-5 to terminate the service, reset the request, and, if Autoinitialize is enabled, to write the base registers to the current registers of that channel. The mask bit and TC bit in the status word will be set for the currently active channel by $\overline{\text{EOP}}$ unless the channel is programmed for Autoinitialize. In that case, the mask bit remains clear. During memory-to-memory transfers, $\overline{\text{EOP}}$ will be output when the TC for channel 1 occurs. $\overline{\text{EOP}}$ should be tied high with a pull-up resistor if it is not used to prevent erroneous end of process inputs.
32 ~ 35	A0-A3	I/O	The four least significant address lines are bidirectional three-state signals. In the Idle cycle they are inputs and are used by the UM8237AE/-4/-5 to address the control register to be loaded or read. In the Active cycle they are outputs and provide the lower 4 bits of the output address.
37 ~ 40	A4-A7	O	The four most significant address lines are three-state outputs and provide 4 bits of address. These lines are enabled only during the DMA service.
10	HRQ	O	This is the Hold Request to the CPU and is used to request control of the system bus. If the corresponding mask bit is clear, the presence of any valid DREQ causes UM8237AE/-4/-5 to issue the HRQ. After HRQ goes active at least one clock cycle (TCY) must occur before HLDA goes active.
25, 24, 14, 15	DACK0-DACK3	O	DMA Acknowledge is used to notify the individual peripherals when one has been granted a DMA cycle. The sense of these lines is programmable. Reset initializes them to active low.

Pin Description (Continued)

Pin No.	Symbol	I/O	Description
9	AEN	O	Address Enable enables the 8-bit latch containing the upper 8 address bits onto the system address bus. AEN can also be used to disable other system bus drivers during DMA transfers. AEN is active HIGH.
Address Strobe	$\overline{\text{ADSTB}}$	O	The active high, Address Strobe is used to strobe the upper address byte into an external latch.
3	$\overline{\text{MEMR}}$	O	The Memory Read signal is an active low, three-state output used to access data from the selected memory location during a DMA Read or a memory-to memory transfer.
4	$\overline{\text{MEMW}}$	O	The Memory Write is an active low, three-state output used to write data to the selected memory location during a DMA Write or a memory-to-memory transfer.

Functional Description

The UM8237AE/-4/-5 block diagram includes the major logic blocks and all of the internal registers. The data interconnection paths are also shown. Not shown are the various control signals between the blocks. The UM8237AE/-4/-5 contains 344 bits of internal memory in the form of registers. Figure 1 lists these registers by name and shows the size of each. A detailed description of the registers and their functions can be found under Register Description.

The UM8237AE/-4/-5 contains three basic blocks of control logic. The Timing Control block generates internal timing and external control signals for the UM8237AE/-4/-5. The Program Command Control block decodes the various commands given to the UM8237AE/-4/-5 by the microprocessor prior to servicing a DMA Request. It also decodes the Mode Control word used to select the type of DMA during the servic-

ing. The Priority Encoder block resolves priority contention between DMA channels requesting service simultaneously.

The Timing Control block derives internal timing from the clock input. In UM8237AE/-4/-5 systems this input will usually be the $\phi 2$ TTL clock from an 8224 or CLK from an 8085AH or 8284A. For 8085AH-2 systems above 3.9 MHz, the 8085 CLK (OUT) does not satisfy UM8237AE/-4/-5 clock LOW and HIGH time requirements. In this case, an external clock should be used to drive the UM8237AE/-4/-5.

DMA Operation

The UM8237AE/-4/-5 is designed to operate in two major cycles. These are called Idle and Active cycles. Each device cycle is made up of a number of states. The UM8237AE/-4/-5 can assume seven separate states, each composed of one full clock period. State 1 (S1) is the inactive state. It is entered when the UM8237AE/-4/-5 has no valid DMA requests pending. While in S1, the DMA controller is inactive but may be in the Program condition, being programmed by the processor. State S0 (S0) is the first state of a DMA service. The UM8237AE/-4/-5 has requested a hold but the processor has not yet returned an acknowledge. The UM8237AE/-4/-5 may still be programmed until it receives HLDA from the CPU. An acknowledge from the CPU will signal that DMA transfers may begin. S1, S2, S3 and S4 are the working states of the DMA service. If more time is needed to complete a transfer than is available with normal timing, wait states (SW) can be inserted between S2 or S3 and S4 by the use of the Ready line on the UM8237AE/-4/-5. Note that the data is transferred directly from the I/O device to memory (or vice versa) with $\overline{\text{IOR}}$ and MEMW (or MEMR and $\overline{\text{IOW}}$) being active at the same time. The data is not read into or driven out of the UM8237AE/-4/-5 in I/O-to-memory or memory-to-I/O DMA transfers.

Name	Size	Number
Base Address Registers	16 bits	4
Base Word Count Registers	16 bits	4
Current Address Registers	16 bits	4
Current Word Count Registers	16 bits	4
Temporary Address Register	16 bits	1
Temporary Word Count Register	16 bits	1
Status Register	8 bits	1
Command Register	8 bits	1
Temporary Register	8 bits	1
Mode Registers	6 bits	4
Mask Register	4 bits	1
Request Register	4 bits	1

Figure 1. UM8237AE/-4/-5 Internal Registers

Memory-to-memory transfers require a read-from and a write-to-memory to complete each transfer. The states, which resemble the normal working states, use two digit numbers for identification. Eight states are required for a single transfer. The first four states (S11, S12, S13, S14) are used for the read-from-memory half and the last four states (S21, S22, S23, S24) for the write-to-memory half of the transfer.

Idle Cycle

When no channel is requesting service, the UM8237AE/-4/-5 will enter the Idle cycle and perform "S1" states. In this cycle, the UM8237AE/-4/-5 will sample the DREQ lines every clock cycle to determine if any channel is requesting a DMA service. The device will also sample \overline{CS} , looking for an attempt by the microprocessor to write or read the internal registers of the UM8237AE/-4/-5. When \overline{CS} is low and HLDA is low, the UM8237AE/-4/-5 enters the Program Condition. The CPU can now establish, change or inspect the internal definition of the part by reading from or writing to the internal registers. Address lines A0-A3 are inputs to the device and select which registers will be read or written. The \overline{IOR} and \overline{LOW} lines are used to select and time reads or writes. Due to the number and size of the internal registers, an internal flip-flop is used to generate an additional bit of address. This bit is used to determine the upper or lower byte of the 16-bit Address and Word Count registers. The flip-flop is reset by Master Clear or Reset. A separate software command can also reset this flip-flop.

Special software commands can be executed by the UM8237AE/-4/-5 in the Program Condition. These commands are decoded as sets of addresses with the \overline{CS} and \overline{IOW} . The commands do not make use of the data bus. Instructions include Clear First/Last Flip-Flop and Master Clear.

Active Cycle

When the UM8237AE/-4/-5 is in the Idle cycle and a non-masked channel requests a DMA service, the device will output an HRQ to the microprocessor and enter the Active cycle. It is in this cycle that the DMA service will take place, in one of four modes:

Single Transfer Mode — In Single Transfer mode the device is programmed to make one transfer only. The word count will be decremented and the address decremented or incremented following each transfer. When the word count "rolls over" from zero to FFFFH, a Terminal Count (TC) will cause an Autoinitialize, if the channel has been programmed to do so.

DREQ must be held active until DACK becomes active in order to be recognized. If DREQ is held active throughout the single transfer, HRQ will go inactive and release the bus to the system. It will again go

active and, upon receipt of a new HLDA, another single transfer will be performed, in 8080A, 8085AH, 8088, or 8086 systems this will ensure one full machine cycle execution between DMA transfers. Details of timing between the UM8237AE/-4/-5 and other bus control protocols will depend upon the characteristics of the microprocessor involved.

Block Transfer Mode — In Block Transfer mode the device is activated by DREQ to continue making transfers during the service until a TC, caused by word count going to FFFFH, or an external End of Process (EOP) is encountered. DREQ need only be held active until DACK becomes active. Again, an Autoinitialization will occur at the end of the service if the channel has been programmed for it.

Demand Transfer Mode — In Demand Transfer mode the device is programmed to continue making transfers until a TC or external EOP is encountered or until DREQ goes inactive. Thus transfers may continue until the I/O device has exhausted its data capacity. After the I/O device has had a chance to catch up, the DMA service is re-established by means of a DREQ. During the time between services, when the microprocessor is allowed to operate, the intermediate values of address and word count are stored in the UM8237AE/-4/-5 Current Address and Current Word Count registers. Only an EOP can cause an Autoinitialize at the end of the service. EOP is generated either by TC or by an external signal.

Cascade Mode — This mode is used to cascade more than one UM8237AE/-4/-5 together for simple system expansion. The HRQ and HLDA signals from the additional UM8237AE/-4/-5 are connected to the DREQ and DACK signals of a channel of the initial UM8237AE/-4/-5. This allows the DMA requests of the additional device to propagate through the priority network circuitry of the preceding device. The priority chain is preserved and the new device must wait for its turn to acknowledge requests. Since the cascade channel of the initial UM8237AE/-4/-5 is used only for prioritizing the additional device, it does not output any address or control signals of its own. These could conflict with the outputs of the active channel in the added device. The UM8237AE/-4/-5 will respond to DREQ and DACK but all other outputs, except HRQ, will be disabled.

Figure 2 shows two additional devices cascaded into an initial device using two of the previous channels. This forms a two level DMA system. More UM8237AE/-4/-5 could be added at the second level by using the remaining channels of the first level. Additional devices can also be added by cascading into the channels of the second level devices, forming a third level.

Transfer Types

Each of the three active transfer modes can perform three different types of transfers. These are Read, Write and Verify. Write transfers move data from an I/O device to the memory by activating MEMW and \overline{IOR} . Read transfers move data from memory to an I/O device by activating MEMR and \overline{IOW} . Verify transfers are pseudo transfers. The UM8237AE/-4/-5 operates, as in Read or Write transfers, generating addresses, and responding to EOP, etc. However, the memory and I/O control lines all remain inactive. Verify mode is not permitted during memory to memory operations.

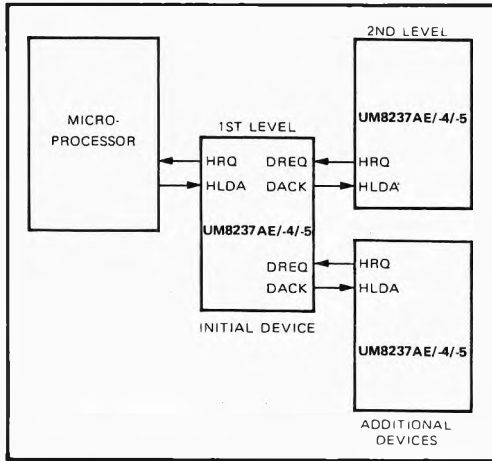

Figure 2. Cascaded UM8237AE/-4/-5

Memory-to-Memory — To perform block moves of data from one memory address space to another with a minimum of program effort and time, the UM8237AE/-4/-5 includes a memory-to-memory transfer feature. Programming a bit in the Command register selects channels 0 and 1 to operate as memory-to-memory transfer channels. The transfer is initiated by setting the software DREQ for channel 0. The UM8237AE/-4/-5 requests a DMA service in the normal manner. After HLDA is true, the device, using eightstate transfers in Block Transfer mode, reads data from the memory. The channel 0 Current Address register is the source for the address used and is decremented or incremented in the normal manner. The data byte read from the memory is stored in the UM8237AE/-4/-5 internal Temporary register. Channel 1 then writes the data from the Temporary register to memory using the address in its Current Address register and incrementing or decrementing it in the normal manner. The channel 1 Current Word Count is decremented. When the word count of channel 1 goes to FFFFH, a TC is generated causing an EOP output, terminating the service.

Channel 0 may be programmed to retain the same address for all transfers. This allows a single word to be written to a block of memory.

The UM8237AE/-4/-5 will respond to external EOP signals during memory-to-memory transfers. Data comparators in block search schemes may use this input to terminate the service when a match is found. The timing of memory-to-memory transfers is found in Figure 10. Memory-to-memory operations can be detected as an active AEN with no DACK outputs.

Autoinitialize — By programming a bit in the Mode register, a channel may be set up as an Autoinitialize channel. During Autoinitialize initialization, the original values of the Current Address and Current Word Count registers are automatically restored from the Base Address and Base Word count registers of that channel following EOP. The base registers are loaded simultaneously with the current registers by the microprocessor and remain unchanged throughout the DMA service. The mask bit is not set when the channel is in Autoini-

tialize. Following Autoinitialize, the channel is ready to perform another DMA service, without CPU intervention, as soon as a valid DREQ is detected.

Priority — The UM8237AE/-4/-5 has two types of priority encoding available as software selectable options. The first is Fixed Priority, which fixes the channels in priority order based upon the descending value of their number. The channel with the lowest priority is 3, followed by 2 and 1, and the highest priority channel, 0. After the recognition of any one channel for service, the other channels are prevented from interfering with that service until it is completed.

The second scheme is Rotating Priority. The last channel to get service becomes the lowest priority channel with the others rotating accordingly.

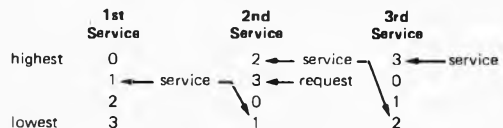

With Rotating Priority in a single chip DMA system, any device requesting service is guaranteed to be recognized after no more than three higher priority services have occurred. This prevents any one channel from monopolizing the system.

Compressed Timing — In order to achieve even greater throughput where system characteristics permit, the UM8237AE/-4/-5 can compress the transfer time to two clock cycles. From Figure 11 it can be seen that state S3 is used to extend the access time of the read pulse. By removing state S3, the read pulse width is made equal to the write pulse width and a transfer consists only of state S2 to change the address and state S4 to perform the read/write. S1 states will still occur when A8-A15 need updating (see Address Generation). Timing for compressed transfers is found in Figure 12.

Address Generation — In order to reduce pin count, the UM8237AE/-4/-5 multiplexes the eight higher order address bits on the data lines. State S1 is used to output the higher order address bits to an external latch, from which they may be placed on the address bus. The falling edge of Address Strobe (ADSTB) is used to load these bits from the data lines to the latch. Address Enable (AEN) is used to enable the bits onto the address bus through a threestate enable. The lower order address bits are output by the UM8237AE/-4/-5 directly. Lines A0-A7 should be connected to the address bus. Figure 9 shows the time relationships between CLK, AEN, ADSTB, DB0-DB7 and A0-A7.

During Block and Demand Transfer mode services, which include multiple transfers, the addresses generated will be sequential. For many transfers the data held in the external address latch will remain the same. This data

need change only when a carry or borrow from A7 to A8 takes place in the normal sequence of addresses. To save time and speed transfers, the UM8237AE/-4/-5 executes S1 states only when updating of A8-A15 in the latch is necessary. This means for long services, S1 states and Address Strokes may occur only once every 256 transfers, a savings of 255 clock cycles for each 256 transfers.

Register Description

Current Address Register — Each channel has a 16-bit Current Address register. This register holds the value of the address used during DMA transfers. The address is automatically incremented or decremented after each transfer and the intermediate values of the address are stored in the Current Address register during the transfer. This register is written or read by the microprocessor in successive 8-bit bytes. It may also be reinitialized by an Autoinitialize back to its original value. Autoinitialize takes place only after an \overline{EOP} .

Current Word Register — Each channel has a 16-bit Current Word Count register. This register determines the number of transfers to be performed. The actual number of transfers will be one more than the number programmed in the Current Word Count register (i.e. programming a count of 100 will result in 101 transfers). The word count is decremented after each transfer. The intermediate value of the word count is stored in the register during the transfer. When the value in the register goes from zero to FFFFH, a TC will be generated. This register is loaded or read in successive 8-bit bytes by the microprocessor in the Program Condition. Following the end of a DMA service it may also be reinitialized, by an Autoinitialization, back to its original value. Autoinitialize can occur only when an \overline{EOP} occurs. If it is not Autoinitialized, this register will have a count of FFFFH after TC.

Base Address and Base Word Count Register — Each channel has a pair of Base Address and Base Word Count registers. These 16-bit registers store the original value of their associated current registers. During Autoinitialize these values are used to restore the current registers to their original values. The base registers are written simultaneously with their corresponding current register in 8-bit bytes in the Program Condition by the microprocessor. These registers cannot be read by the microprocessor.

Command Register — This 8-bit register controls the operation of the UM8237AE/-4/-5. It is programmed by the microprocessor in the Program Condition and is cleared by Reset or a Master Clear instruction. The following table lists the functions of the command bits. See Figure 4 for address coding.

Mode Register — Each channel has a 6-bit Mode register associated with it. When the register is being written

to by the microprocessor in the the Program Condition, bits 0 and 1 determine which channel Mode register is to be written.

Request Register — The UM8237AE/-4/-5 can respond to requests for DMA service which are initiated by software as well as by a DREQ. Each channel has a request bit associated with it in the 4-bit Request register. These are nonmaskable and subject to prioritization by the Priority Encoder network. Each register bit is set or reset separately under software control, or is cleared upon generation of a TC or external \overline{EOP} . The entire register is cleared by a Reset. To set or reset a bit, the software loads the proper form of the data word. See Figure 3 for register address coding. In order to make a software request, the channel must be in Block Mode.

Mask Register — Each channel has associated with it a

Command Register

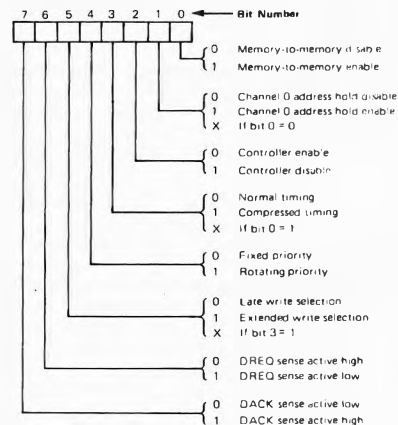

Mode Register

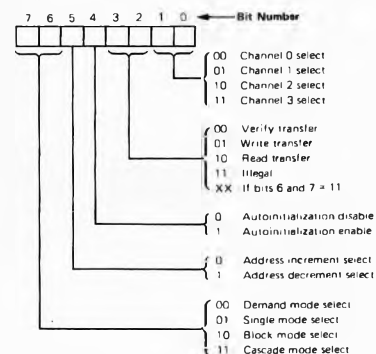

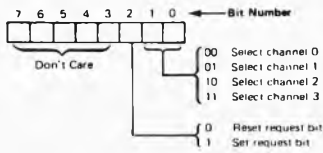
Request Register

mask bit which can be set to disable the incoming DREQ. Each mask bit is set when its associated channel produces an $\overline{\text{EOP}}$, if the channel is not programmed for Autoinitialize. Each bit of the 4-bit Mask register may also be set or cleared separately under software control. The entire register is also set by a Reset. This disables all DMA requests until a clear Mask register instruction allows them to occur. The instruction to separately set or clear the mask bits is similar in form to that used with the Request register. See Figure 3 for instruction addressing.

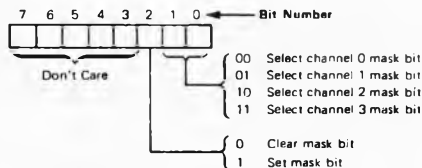

All four bits of the Mask register may also be written with a single command.

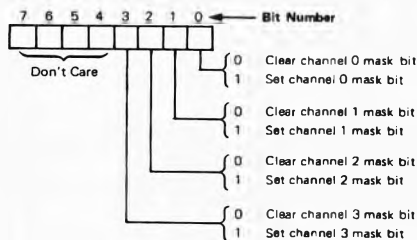

Register	Operation	Signals						
		CS	$\overline{\text{IOR}}$	$\overline{\text{IOW}}$	A3	A2	A1	A0
Command	Write	0	1	0	1	0	0	0
Mode	Write	0	1	0	1	0	1	1
Request	Write	0	1	0	1	0	0	1
Mask	Set/Reset	0	1	0	1	0	1	0
Mask	Write	0	1	0	1	1	1	1
Temporary	Read	0	0	1	1	1	0	1
Status	Read	0	0	1	1	0	0	0

Figure 3. Definition of Register Codes

Status Register — The Status register is available to be read out of the UM8237AE/-4/-5 by the microprocessor. It contains information about the status of the devices at this point. This information includes which channels have reached a terminal count and which channels have

pending DMA requests. Bits 0-3 are set every time a TC is reached by that channel or an external EOP is applied. These bits are cleared upon Reset and on each Status Read. Bits 4-7 are set whenever their corresponding channel is requesting service.

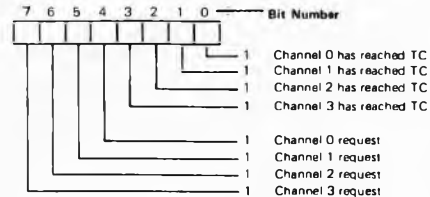

Temporary Register — The Temporary register is used to hold data during memory-to-memory transfers. Following the completion of the transfers, the last word moved can be read by the microprocessor in the Program Condition. The Temporary register always contains the last byte transferred in the previous memory-to-memory operation, unless cleared by a Reset.

Software Commands — These are additional special software commands which can be executed in the Program Condition. They do not depend on any specific bit pattern on the data bus. The two software commands are:

Clear First/Last Flip-Flop: This command is executed prior to writing or reading new address or word count information to the UM8237AE/-4/-5. This initializes the flip-flop to a known state so that subsequent accesses to register contents by the microprocessor will address upper and lower bytes in the correct sequence.

Master Clear: This software instruction has the same effect as the hardware Reset. The Command, Status, Request, Temporary, and Internal First/Last Flip-Flop registers are cleared and the Mask register is set. The UM8237AE/-4/-5 will enter the idle cycle.

Clear Mask Register: This command clears the mask bits of all four channels, enabling them to accept DMA requests.

Figure 4 lists the address codes for the software commands:

PROGRAMMING

The UM8237AE/-4/-5 will accept programming from the host processor any time that HLDA is inactive; this is true even if HRQ is active. The responsibility of the host is to assure that programming and HLDA are mutually exclusive. Note that a problem can occur if a DMA request occurs, on an unmasked channel while the UM8237AE/-4/-5 is being programmed. For instance, the CPU may be starting to reprogram the two byte Address register of channel 1 when channel 1 receives a DMA request. If the UM8237AE/-4/-5 is enabled (bit 2 in the command register is 0) and channel 1 is un-

Signals							Operation
A3	A2	A1	A0	IOR	IOW		
1	0	0	0	0	1		Read Status Register
1	0	0	0	1	0		Write Command Register
1	0	0	1	0	1		Illegal
1	0	0	1	1	0		Write Request Register
1	0	1	0	0	1		Illegal
1	0	1	0	1	0		Write Single Mask Register Bit
1	0	1	1	0	1		Illegal
1	0	1	1	1	0		Write Mode Register
1	1	0	0	0	1		Illegal
1	1	0	0	1	0		Clear Byte Pointer Flip/Flop
1	1	0	1	0	1		Read Temporary Register
1	1	0	1	1	0		Master Clear
1	1	1	0	0	1		Illegal
1	1	1	0	1	0		Clear Mask Register
1	1	1	1	0	1		Illegal
1	1	1	1	1	0		Write All Mask Register Bits

Figure 4. Software Command Codes

masked, a DMA service will occur after only one byte of the Address register has been reprogrammed. This can be avoided by disabling the controller (setting bit 2 in the command register) or masking the channel before

programming any other registers. Once the programming is complete, the controller can be enabled/unmasked.

After power-up it is suggested that all internal locations, especially the Mode registers, be loaded with some valid value. This should be done even if some channels are unused.

Application Information

Figure 6 shows a convenient method for configuring a DMA system with the UM8237AE/-4/-5 controller and an 8080A/8085AH microprocessor system. The multi-mode DMA controller issues a HRQ to the processor whenever there is at least one valid DMA request from a peripheral device. When the processor replies with a HLDA signal, the UM8237AE/-4/-5 takes control of the address bus, the data bus and the control bus. The address for the first transfer operation comes out in two bytes – the least significant 8 bits on the eight address outputs and the most significant 8 bits on the data bus. The contents of the data bus are then latched into the 8282 8-bit latch to complete the full 16 bits of the address bus.

Channel	Register	Operation	Signals							Internal Flip-Flop	Data Bus DB0-DB7
			CS	IOR	IOW	A3	A2	A1	A0		
0	Base and Current Address	Write	0	1	0	0	0	0	0	0	A0-A7 A8-A15
	Current Address	Read	0	0	1	0	0	0	0	0	A0-A7 A8-A15
	Base and Current Word Count	Write	0	1	0	0	0	0	1	0	W0-W7 W8-W15
	Current Word Count	Read	0	0	1	0	0	0	1	0	W0-W7 W8-W15
1	Base and Current Address	Write	0	1	0	0	0	1	0	0	A0-A7 A8-A15
	Current Address	Read	0	0	1	0	0	1	0	0	A0-A7 A8-A15
	Base and Current Word Count	Write	0	1	0	0	0	1	1	0	W0-W7 W8-W15
	Current Word Count	Read	0	0	1	0	0	1	1	0	W0-W7 W8-W15
2	Base and Current Address	Write	0	1	0	0	1	0	0	0	A0-A7 A8-A15
	Current Address	Read	0	0	1	0	1	0	0	0	A0-A7 A8-A15
	Base and Current Word Count	Write	0	1	0	0	1	0	1	0	W0-W7 W8-W15
	Current Word Count	Read	0	0	1	0	1	0	1	0	W0-W7 W8-W15
3	Base and Current Address	Write	0	1	0	0	1	1	0	0	A0-A7 A8-A15
	Current Address	Read	0	0	1	0	1	1	0	0	A0-A7 A8-A15
	Base and Current Word Count	Write	0	1	0	0	1	1	1	0	W0-W7 W8-W15
	Current Word Count	Read	0	0	1	0	1	1	1	0	W0-W7 W8-W15

Figure 5. Word Count and Address Register Command Codes

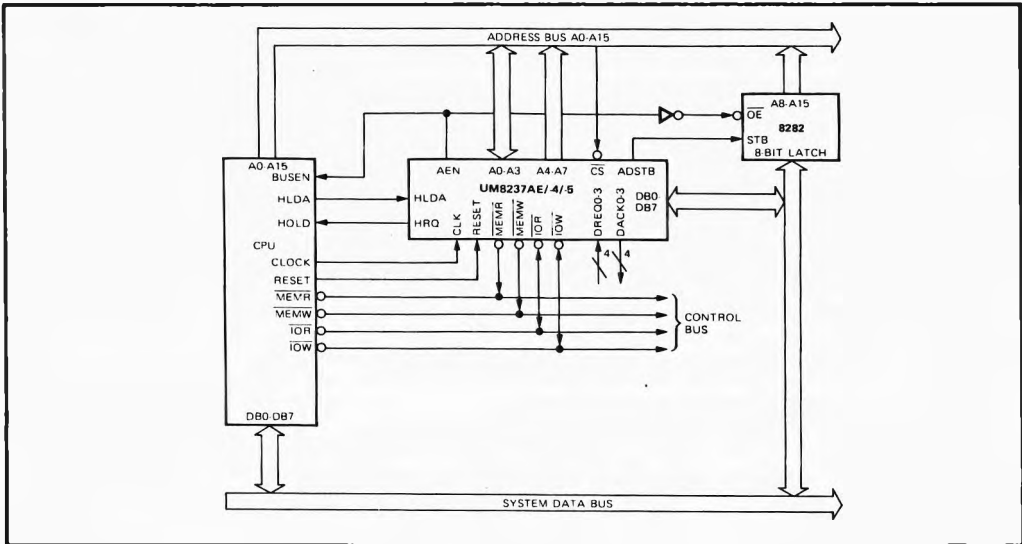

Figure 6. UM8237AE/-4/-5 System Interface

Timing Waveforms

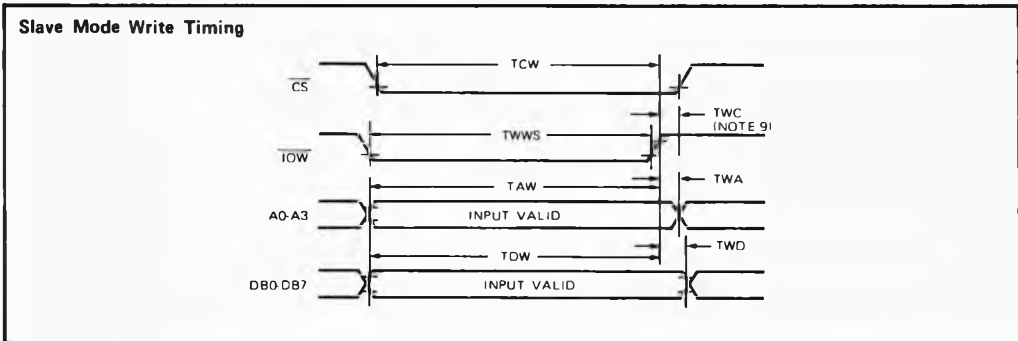

Figure 7. Slave Mode Write

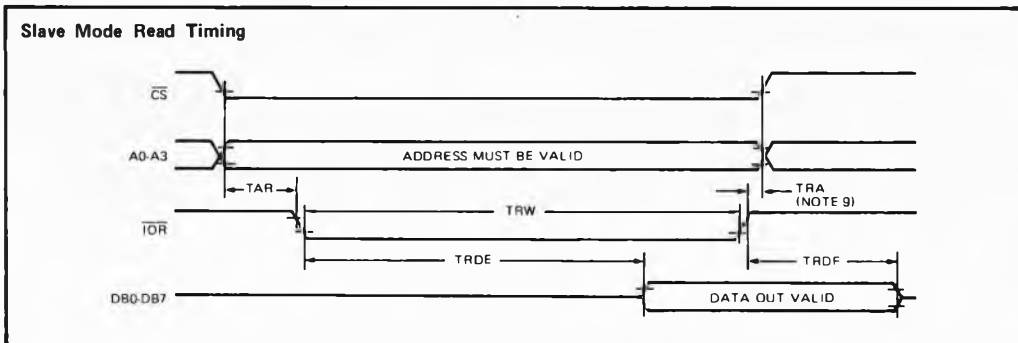
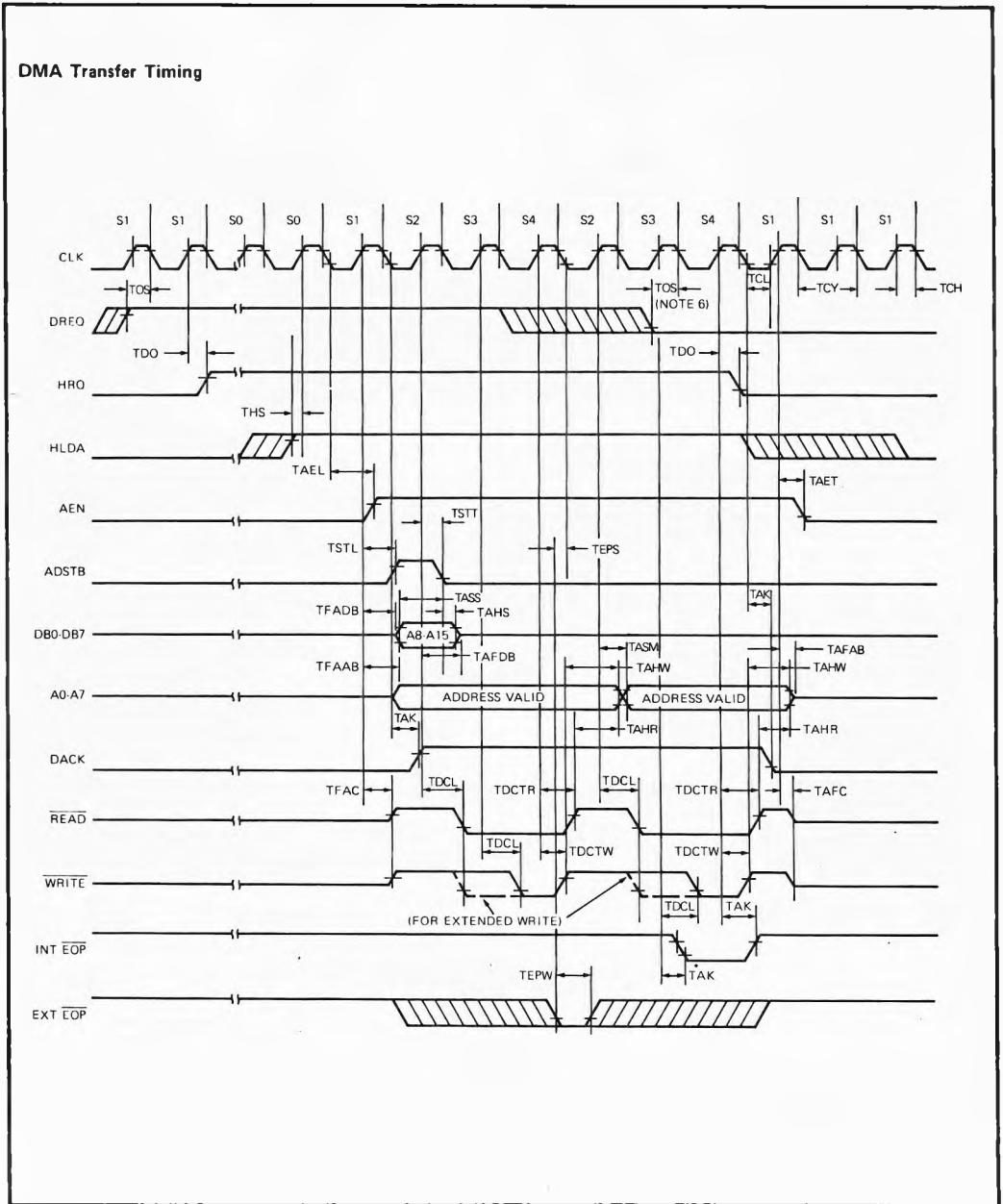
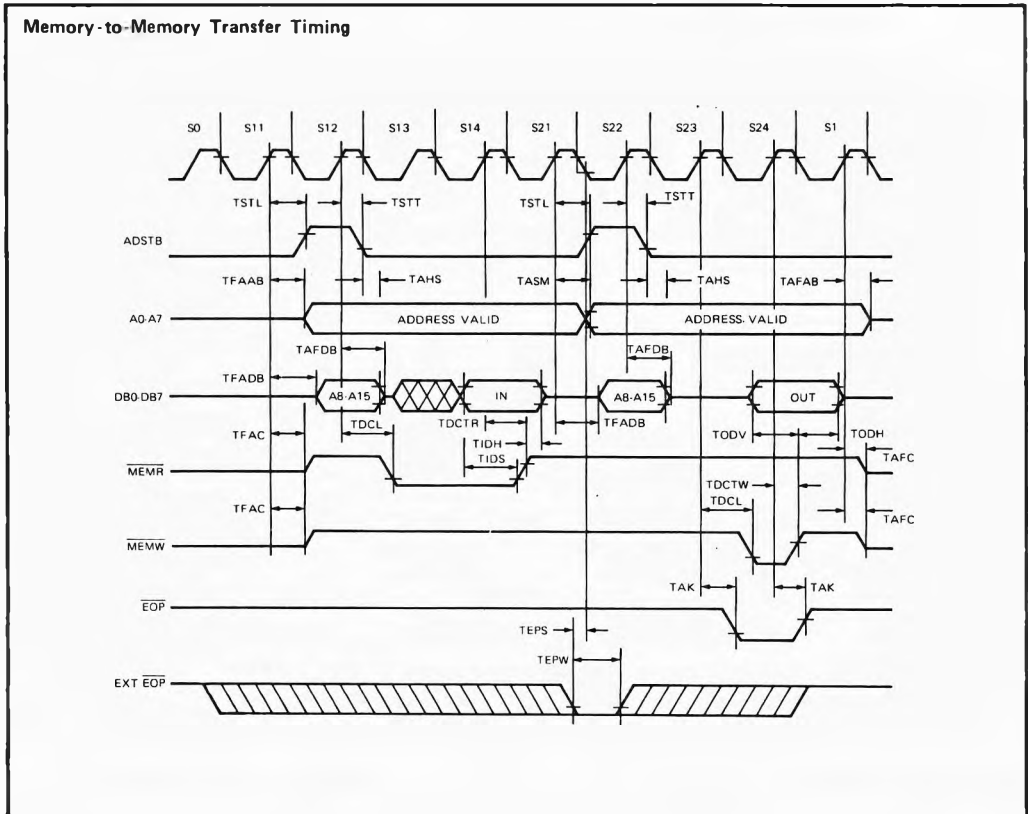
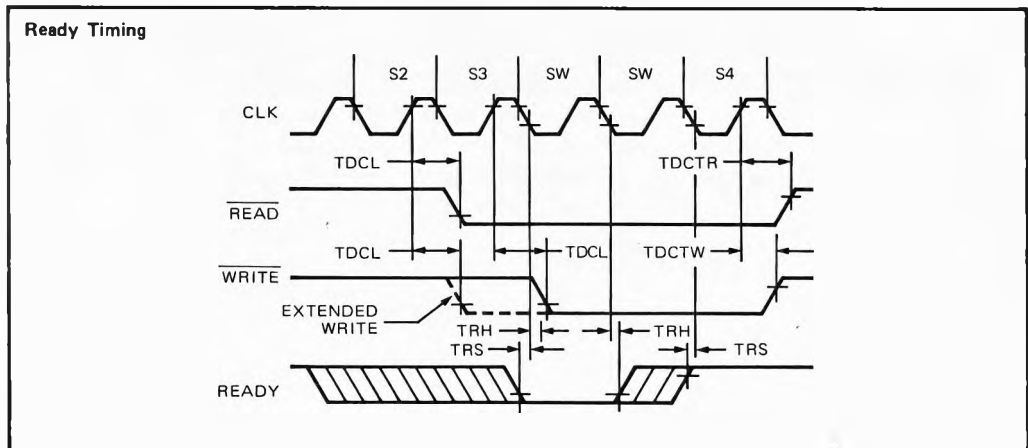
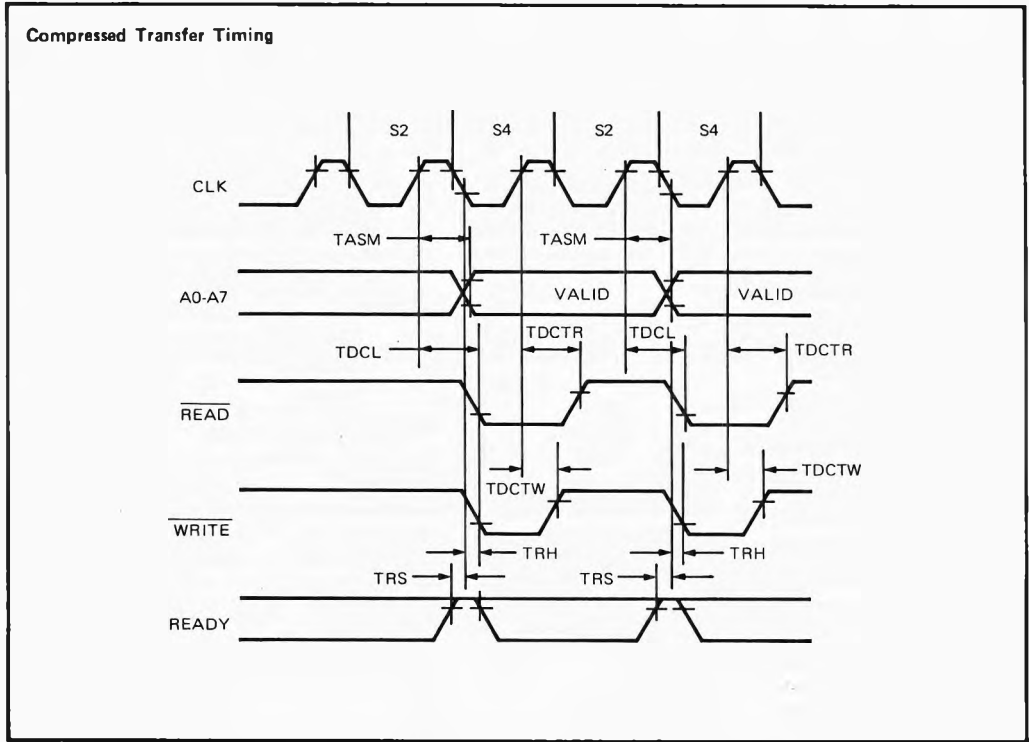
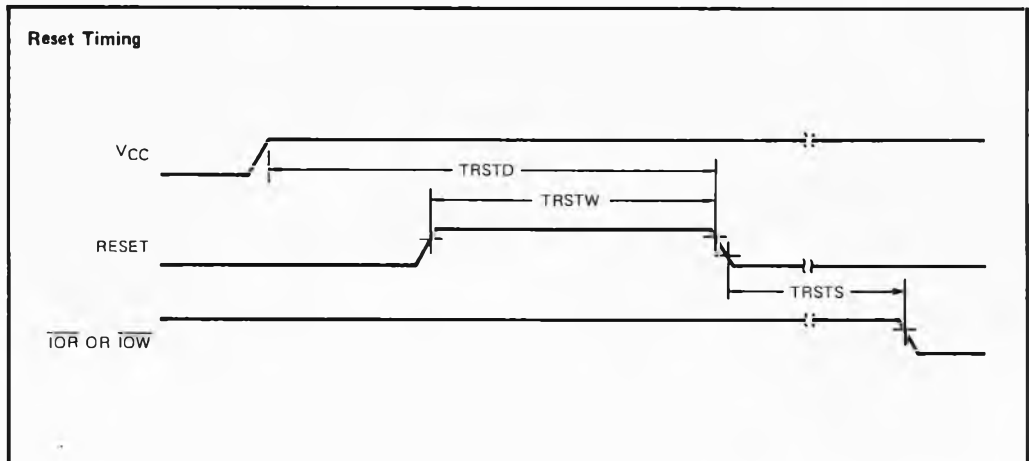

Figure 8. Slave Mode Read

Timing Waveforms (Continued)

Figure 9. DMA Transfer

Timing Waveforms (Continued)

Figure 10. Memory-to-Memory Transfer

Figure 11. Ready

Timing Waveforms (Continued)

Figure 12. Compressed Transfer

Figure 13. Reset

Ordering Information

Part No.	Frequency	Package
UM8237AE	3 MHz	40L DIP
UM8237AE-4	4 MHz	40L DIP
UM8237AE-5	5 MHz	40L DIP