



UM74HCT646

Octal Bus Transceiver and Register

Features

- 8 bi-directional data bus
- Transmits real-time data or stored data in either direction
- 3-state outputs with driving capability for direct bus interface
- Low power consumption with function, pin-out, speed and drive compatibility with 74LS logic family and interfaces directly with TTL, NMOS and CMOS devices
- Available in 24 lead DIP

General Description

The UM74HCT646, fabricated using the UMC silicon gate CMOS process, is a bi-directional bus transceiver with D-type flip-flops and control circuitry arranged for multiplexed transmission of data directly from the input bus or from the internal registers.

Data on the A or B bus will be clocked into the registers on the low-to-high transition of the appropriate clock pin (CAB or CBA). The examples demonstrate the four fundamental bus-management functions that can be performed with the octal bus transceivers and registers.

Pin Configuration

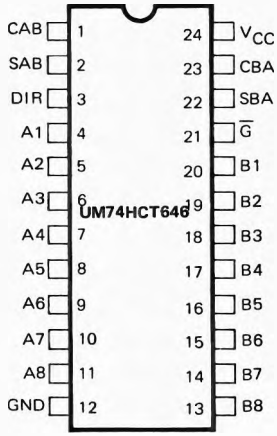

Block Diagram

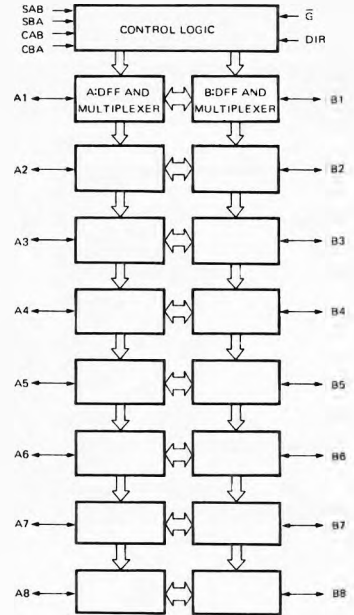

Absolute Maximum Ratings*

Supply Voltage, V_{CC} 7V
 Operating Free-Air Temperature
 Range 0°C to 70°C
 Storage Temperature Range -55°C to 125°C

***Comments**

Stresses above those listed under "Absolute Maximum Ratings" may cause permanent damage to the device. These are stress ratings only. Functional operation of this device at these or any other conditions above those indicated in the operational sections of this specification is not implied and exposure to absolute maximum rating conditions for extended periods may affect device reliability.

D.C. Electrical Characteristics ($V_{CC} = 5V$, $T_A = 25^\circ C$ unless otherwise specified)

Symbol	Parameter	Min.	Typ.	Max.	Unit	Condition
V_{CC}	Power Supply Voltage	4.5	5.0	5.5	V	
V_{IH}	High-Level Input Voltage	2.0	–	–	V	
V_{IL}	Low-Level Input Voltage	–	0.5	0.8	V	
I_I	Input Current (all except I/O pins)	–	0.01	0.1	μA	$V_I = 0V \sim 5V$
V_{OH}	High-Level Output Voltage	4.8	–	–	V	$ I_{OH} = 20 \mu A$
		3.0	–	–	V	$ I_{OH} = \text{Max}$
V_{OL}	Low-Level Output Voltage	–	–	0.1	V	$I_{OL} = 20 \mu A$
		–	–	0.5	V	$I_{OL} = 24 \text{ mA}$
I_{OZ}	3-state Leakage Current When Output is Disabled	–	–	0.5	μA	$V_O = 0 \sim 5V$
I_{CC}	Quiescent Supply Current	–	–	8	μA	$V_{IN} = 0U$ or V_{CC} with No Load

AC Characteristics (Input t_r , $t_f \leq 2 \text{ ns}$)

Symbol	Parameter	Condition [†]	$T_A = 25^\circ C$, $V_{CC} = 5.0V$			Unit
			Min.	Typ.	Max.	
f_{max}	Maximum Clock Frequency	$C_L = 50 \text{ pF}$	30	45	–	MHz
t_{PLH}	Maximum Propagation Delay, A or B Input to B or A Output	$C_L = 50 \text{ pF}$	–	12	25	ns
t_{PHL}		$C_L = 50 \text{ pF}$	–	12	25	
t_{PLH}	Maximum Propagation Delay, CBA or CAB Input to A or B Output	$C_L = 50 \text{ pF}$	–	16	35	ns
t_{PHL}		$C_L = 50 \text{ pF}$	–	16	35	
t_{PLH}	Maximum Propagation Delay, SBA or SAB Input to A or B Output (with A or B High)	$C_L = 50 \text{ pF}$	–	16	35	ns
t_{PHL}		$C_L = 50 \text{ pF}$	–	16	35	
t_{PLH}	Maximum Propagation Delay, SBA or SAB Input to A or B Output (with A or B High)	$C_L = 50 \text{ pF}$	–	16	35	ns
t_{PHL}		$C_L = 50 \text{ pF}$	–	16	35	
t_{PZL}	Maximum Output Enable Time, G or DIR Input to A or B Output	$R_L = 1 \text{ k}\Omega$	$C_L = 50 \text{ pF}$	–	20	ns
t_{PZH}			$C_L = 50 \text{ pF}$	–	20	
t_{PHZ}	Maximum Output Disable Time, G or DIR Input to A or B Output	$R_L = 1 \text{ k}\Omega$ $C_L = 50 \text{ pF}$	–	20	45	ns
t_{PLZ}			–	20	45	
t_w	Pulse Duration, Clock High or Low		12	–	–	ns
t_{SU}	Setup Time, A before CAB \uparrow or B before CAB \uparrow		15	–	–	ns

Pin Description

Symbol	Description
A1 ~ A8	Bi-directional data bus and register input
B1 ~ B8	Bi-directional data bus and register input
\overline{G}	Output enable. This pin is an active low pin, when high all outputs are disabled and A and B ports are isolated.
DIR	Direction control. This pin is used to determine the direction of data flow. When DIR = 1 \Rightarrow From A \rightarrow B DIR = 0 \Rightarrow From B \rightarrow A
SAB SBA	Determines whether data transmitted is from the data inputs or the register associated with those pins. When SAB (SBA) = 1 \Rightarrow Register \rightarrow B (A) Bus. SAB (SBA) = 1 \Rightarrow A (B) \rightarrow B (A)
CAB CBA	Positive trigger clock. When rising edge is triggered, data from A (B) input are loaded into their associated register.

The transceiver function can work only when \overline{G} is active low ($G=0$). DIR determines the direction of data flow. In the transceiver mode, data present at the high-impedance port may be stored in either register or in both.

Enable (\overline{G}) and direction (DIR) pins are provided to control the transceiver functions. In the transceiver mode, data present at the high-impedance port may be stored in either register or in both. The select controls (SAB and SBA) can multiplex stored and real-time (transparent mode)

data. The direction control determines which bus will receive data when enable \overline{G} is active (low). In the isolation mode (control \overline{G} high). Data may be stored in one register and/or B data may be stored in the other register.

When an output function is disabled, the input function is still enabled and may be used to store and transmit data. Only one of the two buses, A or B, may be driven at a time.

Function Table

Inputs						Data I/O [†]		Operation or Function
G	DIR	CAB	CBA	SAB	SBA	A1 Thru A8	B1 Thru B8	
X	X	↑	X	X	X	Input	Not specified	Store A, B unspecified
X	X	X	↑	X	X	Not specified	Input	Store B, A unspecified
H	X	↑	↑	X	X	Input	Input	Store A and B Data
H	X	H or L	H or L	X	X			Isolation, hold storage
L	L	X	H or L	X	L	Output	Input	Real-time B Data to A Bus
L	L	X	X	X	H			Stored B Data to A Bus
L	H	H or L	X	L	X	Input	Output	Real-time A Data to B Bus
L	H	X	X	H	X			Stored A Data to B Bus

[†] The data output functions may be enabled or disabled by various signals at the G and DIR inputs. Data input functions are always enabled, i.e., data at the bus pins will be stored on every low-to-high transition on the clock inputs.

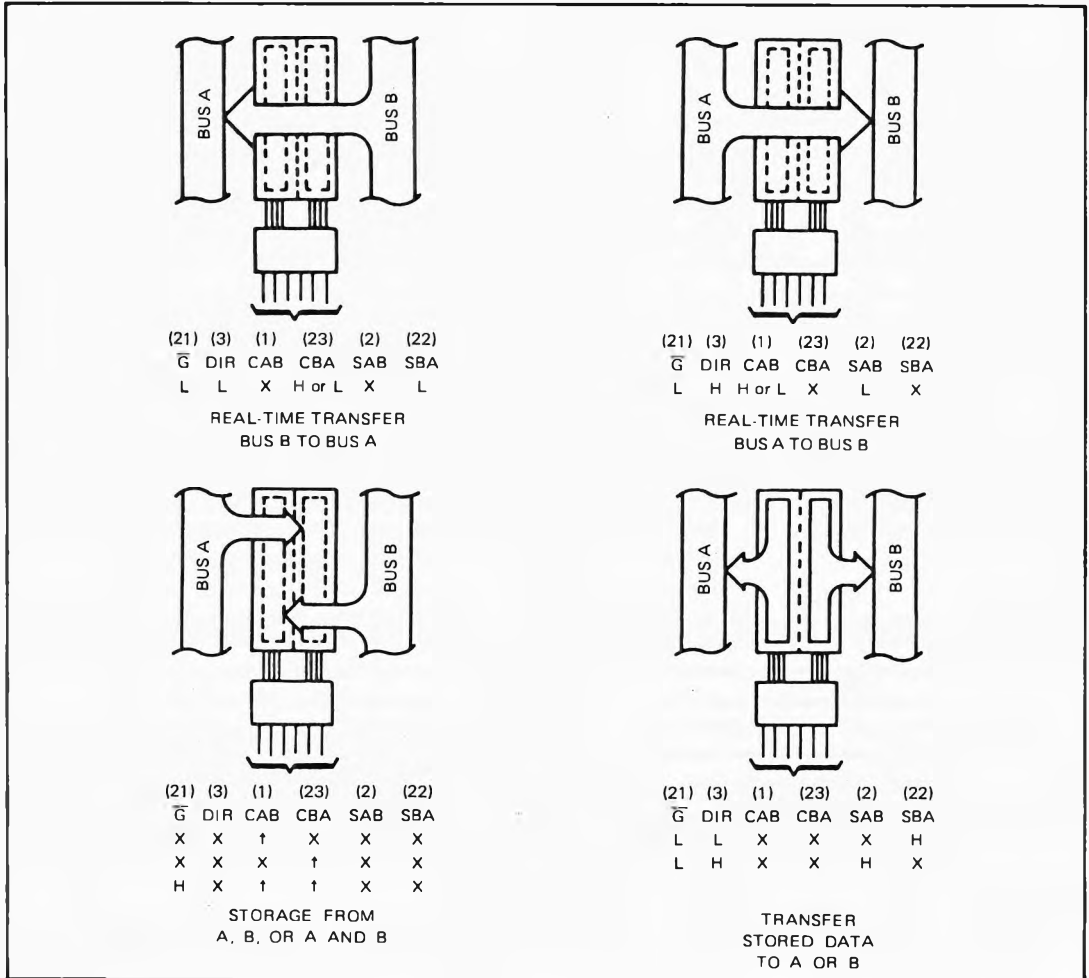
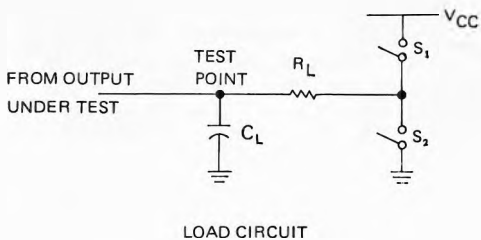
Bus Management Functions

Parameter Measurements

Parameter		R_L	C_L	S_1	S_2
t_{en}	t_{PZH}	1 K Ω	50 pF	OPEN	CLOSED
	t_{PZL}			CLOSED	OPEN
t_{dis}	t_{PHZ}	1 K Ω	50 pF	OPEN	CLOSED
	t_{PLZ}			CLOSED	OPEN

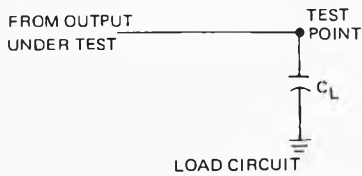
Figure 1. 3-state Outputs

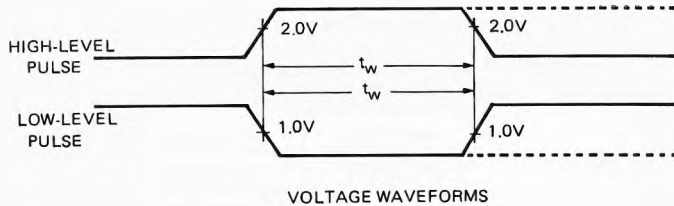
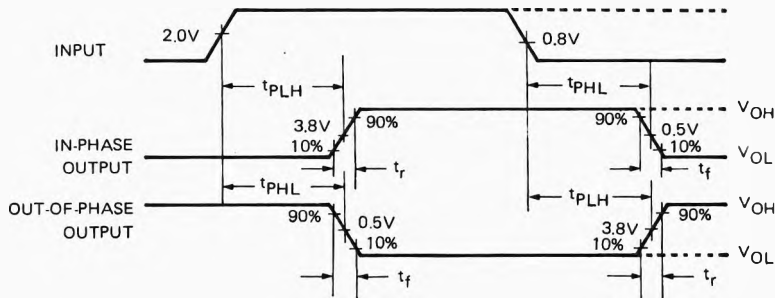
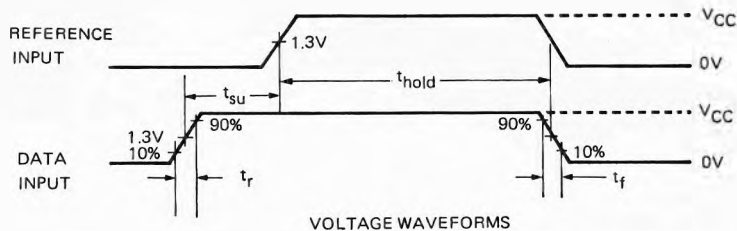

Parameter		C_L
or t_{pd} or t_t	Standard outputs	50 pF
	High-current outputs	50 pF

Figure 2. Totem-Pole Outputs

Figure 3. Pulse Durations

Figure 4. Propagation Delay Times and Output Transition Times

Figure 5. Setup and Hold Times and Input Rise and Fall Time

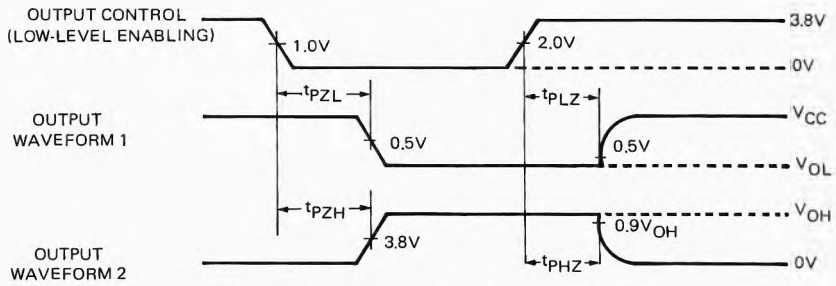

Figure 6. Enable and Disable Times for 3-state Outputs

Ordering Information

Number	Package
UM74HCT646	24L DIP