

HIGH-SPEED VOLTAGE MODE PULSE WIDTH MODULATOR

Check for Samples: [UCC25705-Q1](#), [UCC25706-Q1](#)

FEATURES

- Qualified for Automotive Applications
- Greater Than 4-MHz Operation
- Integrated Oscillator / Voltage Feed Forward Compensation
- >4:1 Input Voltage Range
- 25-ns Current Limit Delay
- Programmable Maximum Duty Cycle Clamp
- Optocoupler Interface
- 50- μ A Start-Up Current
- 4.2-mA Operating Current at 1 MHz
- Latch-Up Exceeds 100mA per JESD78 Class I
- Smallest Footprint of the 8-pin MSOP Package Minimizes Board Area and Height

D PACKAGE
(TOP VIEW)

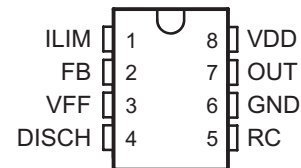

DESCRIPTION

The UCC25705-Q1 and UCC25706-Q1 devices are 8-pin voltage mode primary side controllers with fast over-current protection. These devices are used as core high-speed building blocks in high performance isolated and non-isolated power converters.

UCC25705-Q1/UCC25706-Q1 devices feature a high speed oscillator with integrated feed-forward compensation for improved converter performance. A typical current sense to output delay time of 25 ns provides fast response to overload conditions. The IC also provides an accurate programmable maximum duty cycle clamp for increased protection which can also be disabled for the oscillator to run at maximum possible duty cycle.

Two UVLO options are offered. The UCC25705-Q1 with lower turn-on voltage is intended for dc-to-dc converters while the higher turn-on voltage and the wider UVLO range of the UCC25706-Q1 is better suited for offline applications.

The UCC2570x-Q1 family is offered in an 8-pin SOIC (D) package.



Please be aware that an important notice concerning availability, standard warranty, and use in critical applications of Texas Instruments semiconductor products and disclaimers thereto appears at the end of this data sheet.

Figure 1. TYPICAL APPLICATION SCHEMATIC

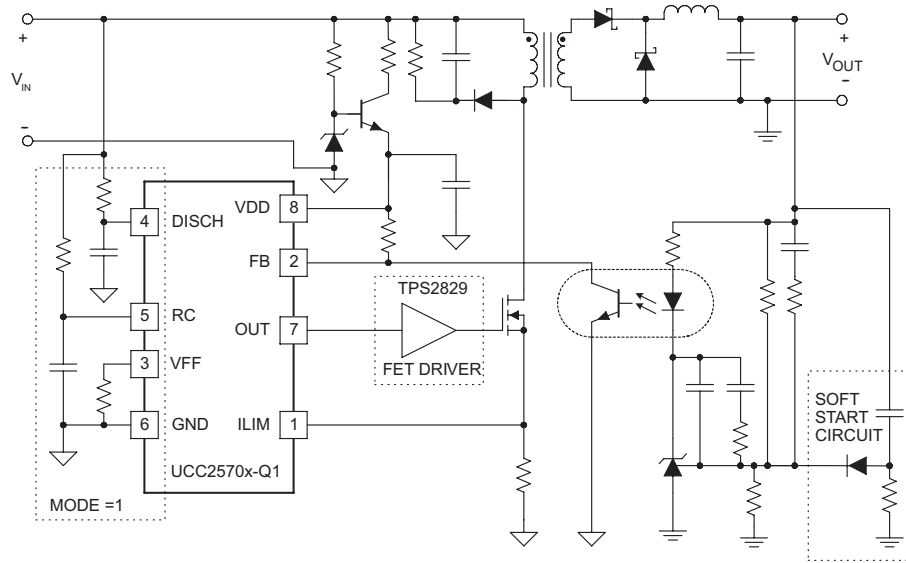

ABSOLUTE MAXIMUM RATINGS

over operating free-air temperature (unless otherwise noted)⁽¹⁾⁽²⁾

	VALUE	UNIT
Supply voltage	15	V
Input voltage (VFF,RC,ILIM)	7	V
Input voltage (FB)	15	V
Input current (DISCH)	1	mA
Output current (OUT) dc	±20	mA
Storage temperature, T _{stg}	-65 to 150	°C
Junction temperature, T _j	-55 to 150	°C
Lead temperature (soldering, 10 sec)	300	°C

- (1) Stresses beyond those listed under “absolute maximum ratings” may cause permanent damage to the device. These are stress ratings only, and functional operation of the device at these or any other conditions beyond those indicated under “recommended operating conditions” is not implied. Exposure to absolute-maximum-rated conditions for extended periods may affect device reliability.
- (2) All voltages are with respect to GND. Currents are positive into, negative out of the specified terminal. Consult ti.com/packaging for more information.

RECOMMENDED OPERATING CONDITIONS

over operating free-air temperature range (unless otherwise noted)

	VALUE	UNIT
T _A Operating ambient temperature	-40 to 105	°C

ORDERING INFORMATION TABLE

T _A	PACKAGE	ORDERABLE PART NUMBER	TOP-SIDE MARKING
-40°C to 125°C	SOIC-8 – D Reel of 2500	UCC25706QDRQ1	25706Q
-40°C to 125°C	SOIC-8 – D Reel of 2500	UCC25705QDRQ1	Preview

ESD RATINGS TABLE

	PARAMETER	VALUE	UNIT
ESD	Human Body Model (HBM)	1000	V
	Charged- Device Model (CDM)	1000	V
	Machine Model (MM)	200	V

ELECTRICAL CHARACTERISTICS

$V_{DD} = 11\text{ V}$, $V_{IN} = 30\text{ V}$, $R_T = 47\text{ k}$, $R_{DISCH} = 400\text{ k}$, $R_{FF} = 14\text{ k}$, $C_T = 220\text{ pF}$, $C_{VDD} = 0.1\text{ }\mu\text{F}$, and no load on the outputs, $T_A = -40^\circ$ to 125°C , (unless otherwise specified)

PARAMETER	TEST CONDITIONS	MIN	TYP	MAX	UNIT
UVLO section (UCCx5705)					
Start threshold		8.0	8.8	9.6	V
Stop threshold		7.4	8.2	9.0	V
Hysteresis		0.3	0.6	1.0	V
UVLO section (UCCx5706)					
Start threshold		11.2	12.0	12.8	V
Stop threshold		7.2	8.0	8.8	V
Hysteresis		3.2	4.0	4.5	V
Supply Current Section					
Start-up current	$V_{DD} = \text{UVLO start} - 1\text{ V}$, V_{DD} comparator off		30	90	μA
I_{DD} active	V_{DD} comparator on, oscillator running at 1 MHz		4.2	5.0	mA
Line Sense Section					
Low line comparator threshold		0.95	1.00	1.15	V
Input bias current (VFF)		-100		100	nA
Oscillator Section					
Frequency	VFF = 1.2 V to 4.8 V	0.9	1.0	1.1	MHz
CT peak voltage	VFF = 1.2 V, See ⁽¹⁾		1.2		V
	VFF = 4.8 V, See ⁽¹⁾		4.8		V
CT valley voltage	See ⁽¹⁾		0		V
Current Limit Section					
Input bias current		0.2	-0.2	-1	μA
Current limit threshold		180	200	220	mV
Propagation delay, ILIM to OUT	50 mV overdrive		25	35	ns
Pulse Width Modulator Section					
FB input impedance	$V_{FB} = 3\text{ V}$	30	50	90	$\text{k}\Omega$
Minimum duty cycle	$V_{FB} < 2\text{ V}$			0	%
Maximum duty cycle	$V_{FB} = V_{DD}$, $F_{OSC} = 1\text{ MHz}$	70	75	80	%
	$V_{DISCH} = 0\text{ V}$, $F_{OSC} = 1\text{ MHz}$		93		%
PWM gain	$V_{FF} = 2.5\text{ V}$, $\text{MODE} = 1$		12		%/V
Propagation delay, PWM to OUT			65	130	ns
Output Section					
V_{OH}	$I_{OUT} = -5\text{ mA}$, V_{DD} – output		0.3	0.6	V
V_{OL}	$I_{OUT} = 5\text{ mA}$		0.15	0.4	V
Rise time	$C_{LOAD} = 50\text{ pF}$		10	25	ns
Fall time	$C_{LOAD} = 50\text{ pF}$		10	25	ns

(1) Specified by design.

PIN DESCRIPTIONS

DISCH: A resistor to VIN sets the oscillator discharge current programming a maximum duty cycle. When grounded, an internal comparator switches the oscillator to a quick discharge mode. A small 100-pF capacitor between DISCH and GND may reduce oscillator jitter without impacting feed-forward performance. I_{DISCH} must be between 25 μ A and 250 μ A over the entire V_{IN} range.

FB: Input to the PWM comparator. This pin is intended to interface with an optocoupler. Input impedance is 50-k Ω typical.

GND: Ground return pin.

I_{LIM}: Provides a pulse-by-pulse current limit by terminating the PWM pulse when the input is above 200 mV. This provides a high speed (25 ns typical) path to reset the PWM latch, allowing for a pulse-by-pulse current limit.

OUT: The output is intended to drive an external FET driver or other high impedance circuits, but is not intended to directly drive a power MOSFET. This improves the controller's noise immunity. The output resistance of the PWM controller, typically 60 Ω pull-up and 30 Ω pull-down, will result in excessive rise and fall times if a power MOSFET is directly driven at the speeds for which the UCC2570x-Q1 is optimized.

RC: The oscillator can be configured to provide a maximum duty cycle clamp. In this mode the on-time is set by RT and CT, while the off-time is set by R_{DISCH} and CT. Since the voltage ramp on CT is proportional to V_{IN} , feed-forward action is obtained. Since the peak oscillator voltage is also proportional to V_{IN} , constant frequency operation is maintained over the full power supply input range. When the DISCH pin is grounded, the duty cycle clamp is disabled. The RC pin then provides a low impedance path to ground CT during the off time.

V_{DD}: Power supply pin. This pin should be bypassed with a 0.1- μ F capacitor for proper operation. The undervoltage lockout function of the UCC2570x-Q1 allows for a low current startup mode and ensures that all circuits become active in a known state. The UVLO thresholds on the UCC25705-Q1 are appropriate for a dc-to-dc converter application. The wider UVLO hysteresis of the UCC25706-Q1 (typically 4 V) is optimized for a bootstrap startup mode from a high impedance source.

V_{FF}: The feed-forward pin provides the controller with a voltage proportional to the power supply input voltage. When the oscillator is providing a duty cycle clamp, a current of $2 \times I_{DISCH}$ is sourced from the V_{FF} pin. A single resistor R_{FF} between V_{FF} and GND then set V_{FF} to:

$$V_{FF} \approx V_{IN} \times \left(\frac{2 \times R_{FF}}{2 \times R_{FF} + R_{DISCH}} \right)$$

When the DISCH pin is grounded and the duty cycle clamp is not used, the internal current source is disabled and a resistor divider from V_{IN} is used to set V_{FF} . In either case, when the voltage on V_{FF} is less than 1.0 V, both the output and oscillator are disabled.

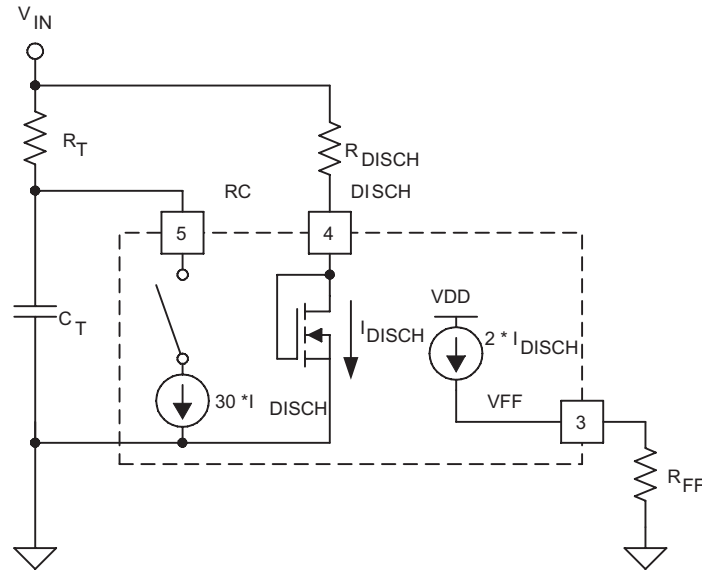

Figure 3. Duty Cycle Clamp (MODE = 1)

The on-time is approximately:

$$T_{ON} = \alpha \times R_T \times C_T \text{ where } \alpha = \frac{V_{FF}}{V_{IN}} \approx \frac{2 \times R_{FF}}{R_{DISCH}}$$

The off-time is:

$$T_{OFF} = \alpha \times \frac{C_T \times (R_T \times R_{DISCH})}{30 \times R_T - R_{DISCH}}$$

The frequency is:

$$f = \frac{1}{\alpha \times R_T \times C_T} \times \frac{1}{1 + \frac{R_{DISCH}}{30 \times R_T - R_{DISCH}}}$$

The maximum duty cycle is:

$$\text{Duty Cycle} = \frac{T_{ON}}{T_{ON} + T_{OFF}} = \left(1 - \frac{R_{DISCH}}{30 \times R_T} \right)$$

Component Selection for Oscillator With Duty Cycle Clamp (MODE = 1)

For a power converter with the following specifications:

- $V_{IN(min)} = 18\text{ V}$
- $V_{IN(max)} = 75\text{ V}$
- $V_{IN(shutdown)} = 15\text{ V}$
- $F_{OSC} = 1\text{ MHz}$
- $MAX = 0.78$ at $V_{IN(min)}$

In this mode, the on-time is approximately:

- $T_{ON(max)} = 780\text{ ns}$
- $T_{OFF(min)} = 220\text{ ns}$
- $V_{FF(min)} = \frac{18}{15} = 1.20\text{ V}$

1. Pick $C_T = 220\text{ pF}$.
2. Calculate R_T .

$$R_T = \frac{V_{IN(min)} \times T_{ON(max)}}{V_{FF(min)} \times C_T}$$

$$R_T = 51.1\text{ k}\Omega$$

3. R_{DISCH}

$$R_{DISCH} = \frac{30 \times R_T}{1 + \left(\frac{\left(\frac{V_{FF(min)}}{V_{IN(min)}} \right) \times R_T \times C_T}{T_{OFF(min)}} \right)}$$

$$R_{DISCH} = 383\text{ k}\Omega.$$

I_{DISCH} must be between $25\text{ }\mu\text{A}$ and $250\text{ }\mu\text{A}$ over the entire V_{IN} range.

With the calculated values, I_{DISCH} ranges from $44\text{ }\mu\text{A}$ to $193\text{ }\mu\text{A}$, within the allowable range. If I_{DISCH} is too high, C_T must be decreased.

4. R_{FF}

$$R_{FF} = \frac{V_{FF(min)} \times R_{DISCH}}{2 \times (V_{IN(min)} - 1)}$$

The nearest 1% standard value to the calculated value is 13.7 k .

Oscillator Without Duty Cycle Clamp (MODE = 0)

In this mode, the timing capacitor is discharged through a low impedance directly to ground. The DISCH pin is externally grounded. A comparator connected to DISCH senses the ground connection and disables both the discharge current source and V_{FF} current source. A resistor divider is now required to set V_{FF} .

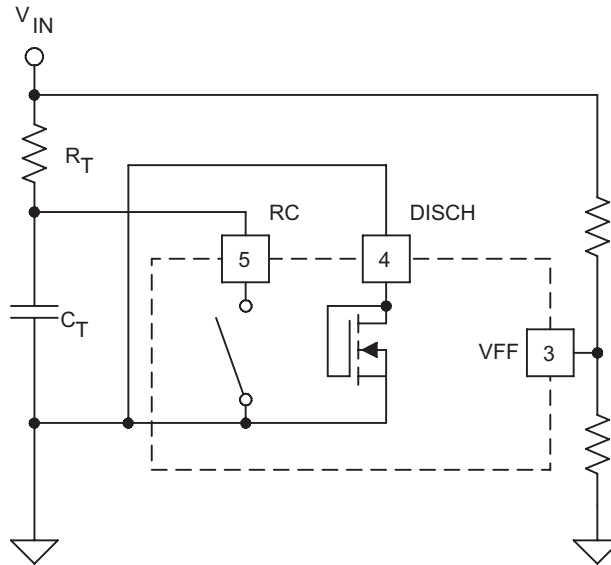

Figure 4. Oscillator Without Clamp (MODE = 0)

In this mode, the on-time is approximately: $T_{ON} = \alpha \times R_T \times C_T$ where $\alpha = \frac{V_{FF}}{V_{IN}}$

The off-time is: $T_{OFF} \approx 75 \text{ ns}$

The frequency is:

$$f = \frac{1}{\alpha \times R_T \times C_T + 75 \text{ ns}}$$

Component Selection for Oscillator Without Duty Cycle Clamp (MODE = 0)

For a power converter with the following specifications:

- $V_{IN(min)} = 18\text{ V}$
- $V_{IN(max)} = 75\text{ V}$
- $V_{IN(shutdown)} = 15\text{ V}$
- $F_{OSC} = 1\text{ MHz}$

With these specifications,

$$V_{FF(min)} = \frac{18}{15} = 1.2\text{V}$$

1. Pick $C_T = 220\text{ pF}$
2. Calculate R_T .

$$R_T = \frac{V_{IN(min)}}{V_{FF(min)}} \times \left(\frac{1}{F_{OSC}} - 75\text{ns} \right)$$
$$R_T = \frac{V_{IN(min)}}{V_{FF(min)}} \times \frac{1}{C_T}$$

TYPICAL CHARACTERISTICS

UCC25705-Q1 UVLO THRESHOLDS
vs
TEMPERATURE

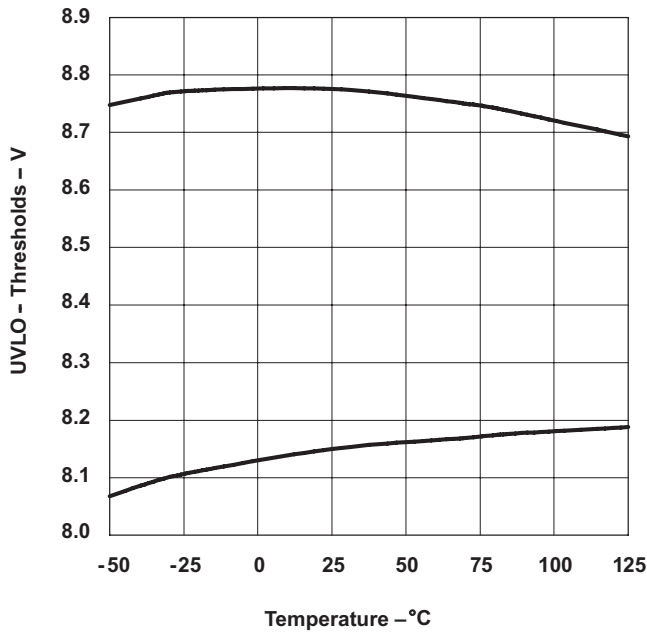

Figure 5.

UCC25706-Q1 UVLO THRESHOLDS
vs
TEMPERATURE

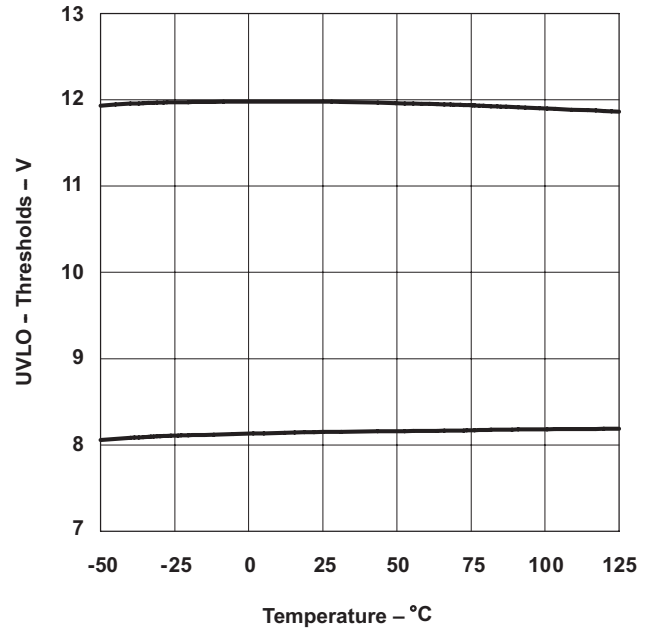

Figure 6.

OPERATING CURRENT (AT 1MHz)
vs
TEMPERATURE

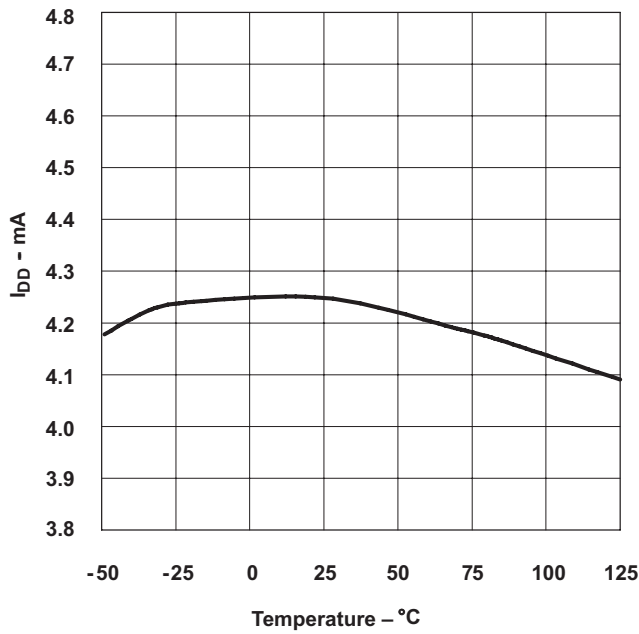

Figure 7.

LOW-LINE THRESHOLD
vs
TEMPERATURE

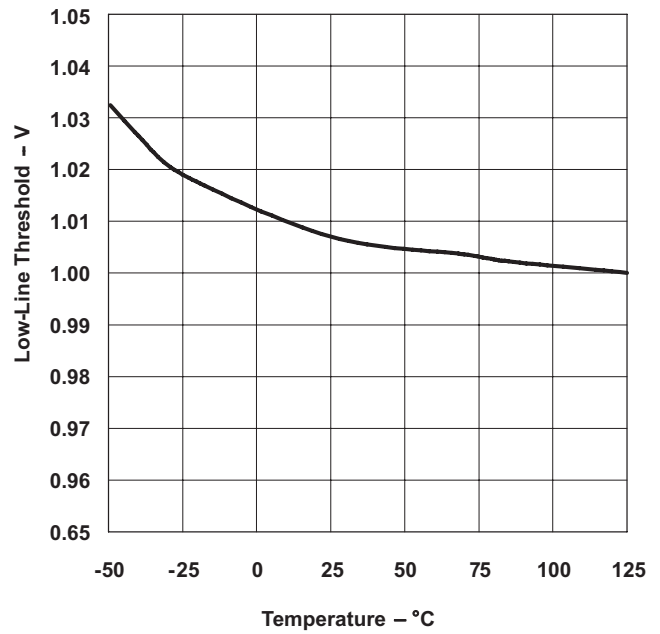

Figure 8.

TYPICAL CHARACTERISTICS

OSCILLATOR FREQUENCY
vs
TEMPERATURE

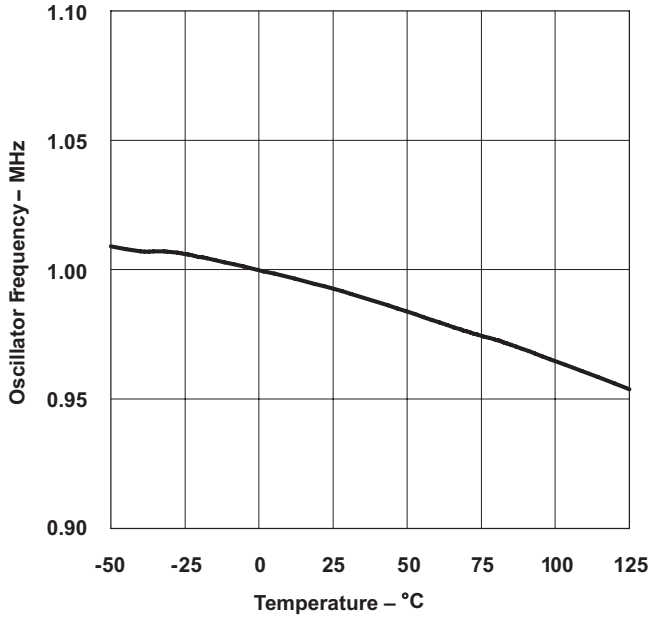

Figure 9.

PROGRAMMABLE MAXIMUM
DUTY CYCLE
vs
TEMPERATURE

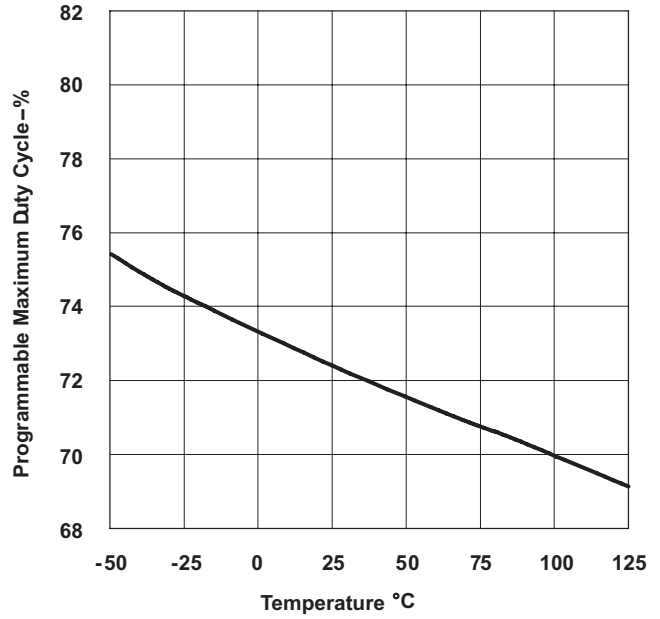

Figure 10.

CURRENT-LIMIT THRESHOLD
vs
TEMPERATURE

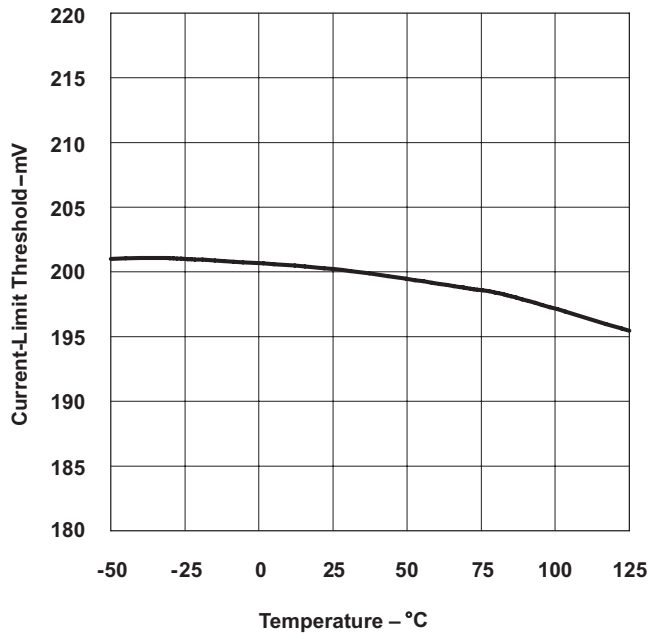

Figure 11.

CURRENT-LIMIT PROP DELAY
vs
TEMPERATURE

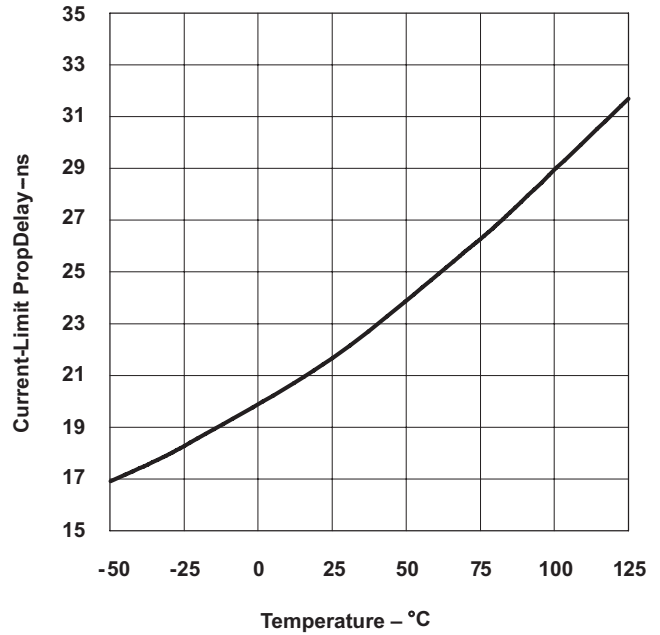

Figure 12.

PACKAGING INFORMATION

Orderable Device	Status (1)	Package Type	Package Drawing	Pins	Package Qty	Eco Plan (2)	Lead/Ball Finish	MSL Peak Temp (3)	Op Temp (°C)	Top-Side Markings (4)	Samples
UCC25706QDRQ1	ACTIVE	SOIC	D	8	2500	Green (RoHS & no Sb/Br)	CU NIPDAU	Level-1-260C-UNLIM	-40 to 125	25706Q	Samples

(1) The marketing status values are defined as follows:

ACTIVE: Product device recommended for new designs.

LIFEBUY: TI has announced that the device will be discontinued, and a lifetime-buy period is in effect.

NRND: Not recommended for new designs. Device is in production to support existing customers, but TI does not recommend using this part in a new design.

PREVIEW: Device has been announced but is not in production. Samples may or may not be available.

OBSOLETE: TI has discontinued the production of the device.

(2) Eco Plan - The planned eco-friendly classification: Pb-Free (RoHS), Pb-Free (RoHS Exempt), or Green (RoHS & no Sb/Br) - please check <http://www.ti.com/productcontent> for the latest availability information and additional product content details.

TBD: The Pb-Free/Green conversion plan has not been defined.

Pb-Free (RoHS): TI's terms "Lead-Free" or "Pb-Free" mean semiconductor products that are compatible with the current RoHS requirements for all 6 substances, including the requirement that lead not exceed 0.1% by weight in homogeneous materials. Where designed to be soldered at high temperatures, TI Pb-Free products are suitable for use in specified lead-free processes.

Pb-Free (RoHS Exempt): This component has a RoHS exemption for either 1) lead-based flip-chip solder bumps used between the die and package, or 2) lead-based die adhesive used between the die and leadframe. The component is otherwise considered Pb-Free (RoHS compatible) as defined above.

Green (RoHS & no Sb/Br): TI defines "Green" to mean Pb-Free (RoHS compatible), and free of Bromine (Br) and Antimony (Sb) based flame retardants (Br or Sb do not exceed 0.1% by weight in homogeneous material)

(3) MSL, Peak Temp. -- The Moisture Sensitivity Level rating according to the JEDEC industry standard classifications, and peak solder temperature.

(4) Only one of markings shown within the brackets will appear on the physical device.

Important Information and Disclaimer: The information provided on this page represents TI's knowledge and belief as of the date that it is provided. TI bases its knowledge and belief on information provided by third parties, and makes no representation or warranty as to the accuracy of such information. Efforts are underway to better integrate information from third parties. TI has taken and continues to take reasonable steps to provide representative and accurate information but may not have conducted destructive testing or chemical analysis on incoming materials and chemicals. TI and TI suppliers consider certain information to be proprietary, and thus CAS numbers and other limited information may not be available for release.

In no event shall TI's liability arising out of such information exceed the total purchase price of the TI part(s) at issue in this document sold by TI to Customer on an annual basis.

OTHER QUALIFIED VERSIONS OF UCC25706-Q1 :

- Catalog: [UCC25706](#)

NOTE: Qualified Version Definitions:

- Catalog - TI's standard catalog product

TAPE AND REEL INFORMATION

QUADRANT ASSIGNMENTS FOR PIN 1 ORIENTATION IN TAPE

*All dimensions are nominal

Device	Package Type	Package Drawing	Pins	SPQ	Reel Diameter (mm)	Reel Width W1 (mm)	A0 (mm)	B0 (mm)	K0 (mm)	P1 (mm)	W (mm)	Pin1 Quadrant
UCC25706QDRQ1	SOIC	D	8	2500	330.0	12.4	6.4	5.2	2.1	8.0	12.0	Q1

TAPE AND REEL BOX DIMENSIONS



*All dimensions are nominal

Device	Package Type	Package Drawing	Pins	SPQ	Length (mm)	Width (mm)	Height (mm)
UCC25706QDRQ1	SOIC	D	8	2500	367.0	367.0	35.0

D (R-PDSO-G8)

PLASTIC SMALL OUTLINE

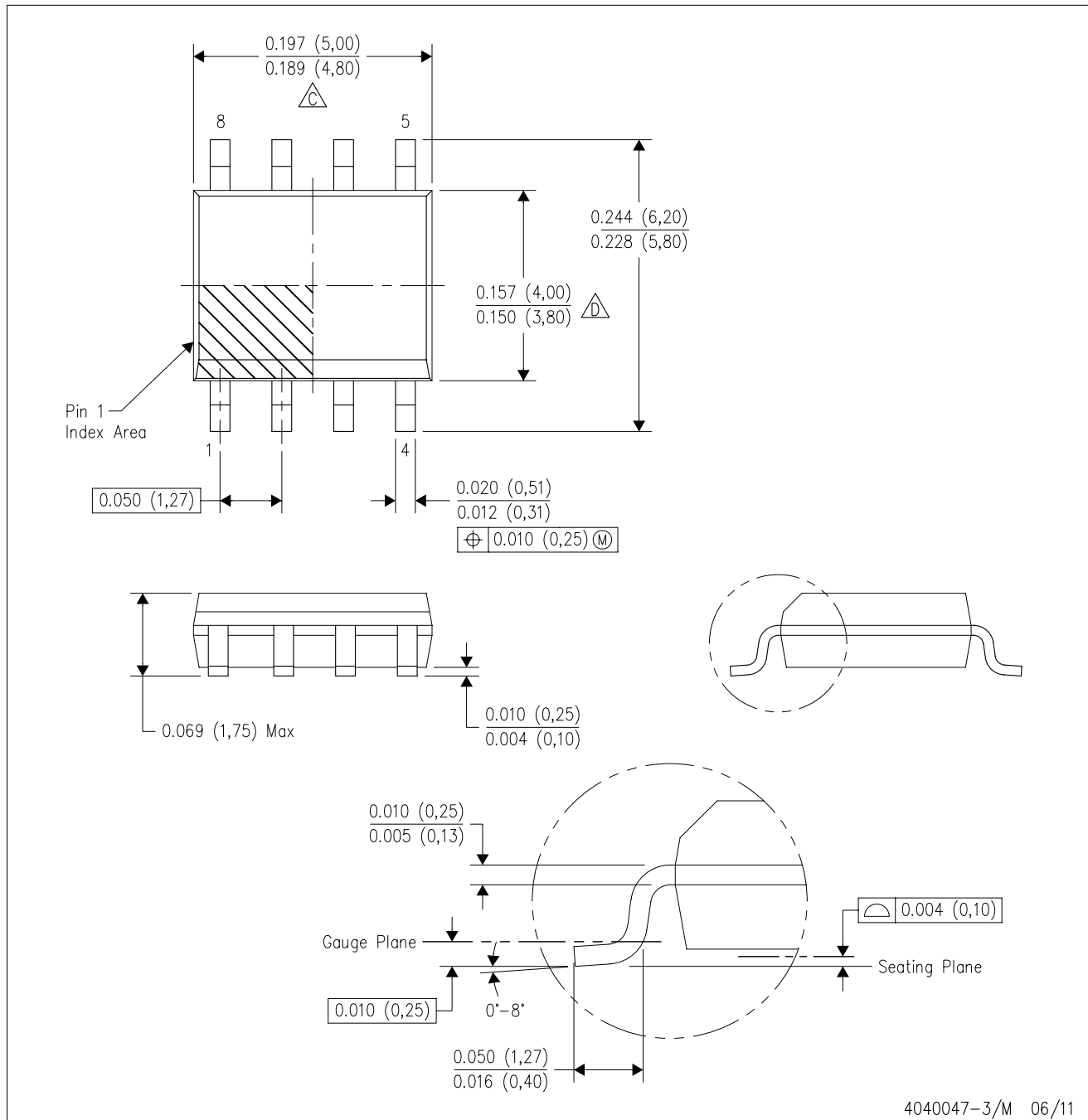

NOTES: A. All linear dimensions are in inches (millimeters).
 B. This drawing is subject to change without notice.
 C. Body length does not include mold flash, protrusions, or gate burrs. Mold flash, protrusions, or gate burrs shall not exceed 0.006 (0,15) each side.
 D. Body width does not include interlead flash. Interlead flash shall not exceed 0.017 (0,43) each side.
 E. Reference JEDEC MS-012 variation AA.

D (R-PDSO-G8)

PLASTIC SMALL OUTLINE



4211283-2/E 08/12

- NOTES:
- All linear dimensions are in millimeters.
 - This drawing is subject to change without notice.
 - Publication IPC-7351 is recommended for alternate designs.
 - Laser cutting apertures with trapezoidal walls and also rounding corners will offer better paste release. Customers should contact their board assembly site for stencil design recommendations. Refer to IPC-7525 for other stencil recommendations.
 - Customers should contact their board fabrication site for solder mask tolerances between and around signal pads.

IMPORTANT NOTICE

Texas Instruments Incorporated and its subsidiaries (TI) reserve the right to make corrections, enhancements, improvements and other changes to its semiconductor products and services per JESD46, latest issue, and to discontinue any product or service per JESD48, latest issue. Buyers should obtain the latest relevant information before placing orders and should verify that such information is current and complete. All semiconductor products (also referred to herein as "components") are sold subject to TI's terms and conditions of sale supplied at the time of order acknowledgment.

TI warrants performance of its components to the specifications applicable at the time of sale, in accordance with the warranty in TI's terms and conditions of sale of semiconductor products. Testing and other quality control techniques are used to the extent TI deems necessary to support this warranty. Except where mandated by applicable law, testing of all parameters of each component is not necessarily performed.

TI assumes no liability for applications assistance or the design of Buyers' products. Buyers are responsible for their products and applications using TI components. To minimize the risks associated with Buyers' products and applications, Buyers should provide adequate design and operating safeguards.

TI does not warrant or represent that any license, either express or implied, is granted under any patent right, copyright, mask work right, or other intellectual property right relating to any combination, machine, or process in which TI components or services are used. Information published by TI regarding third-party products or services does not constitute a license to use such products or services or a warranty or endorsement thereof. Use of such information may require a license from a third party under the patents or other intellectual property of the third party, or a license from TI under the patents or other intellectual property of TI.

Reproduction of significant portions of TI information in TI data books or data sheets is permissible only if reproduction is without alteration and is accompanied by all associated warranties, conditions, limitations, and notices. TI is not responsible or liable for such altered documentation. Information of third parties may be subject to additional restrictions.

Resale of TI components or services with statements different from or beyond the parameters stated by TI for that component or service voids all express and any implied warranties for the associated TI component or service and is an unfair and deceptive business practice. TI is not responsible or liable for any such statements.

Buyer acknowledges and agrees that it is solely responsible for compliance with all legal, regulatory and safety-related requirements concerning its products, and any use of TI components in its applications, notwithstanding any applications-related information or support that may be provided by TI. Buyer represents and agrees that it has all the necessary expertise to create and implement safeguards which anticipate dangerous consequences of failures, monitor failures and their consequences, lessen the likelihood of failures that might cause harm and take appropriate remedial actions. Buyer will fully indemnify TI and its representatives against any damages arising out of the use of any TI components in safety-critical applications.

In some cases, TI components may be promoted specifically to facilitate safety-related applications. With such components, TI's goal is to help enable customers to design and create their own end-product solutions that meet applicable functional safety standards and requirements. Nonetheless, such components are subject to these terms.

No TI components are authorized for use in FDA Class III (or similar life-critical medical equipment) unless authorized officers of the parties have executed a special agreement specifically governing such use.

Only those TI components which TI has specifically designated as military grade or "enhanced plastic" are designed and intended for use in military/aerospace applications or environments. Buyer acknowledges and agrees that any military or aerospace use of TI components which have **not** been so designated is solely at the Buyer's risk, and that Buyer is solely responsible for compliance with all legal and regulatory requirements in connection with such use.

TI has specifically designated certain components as meeting ISO/TS16949 requirements, mainly for automotive use. In any case of use of non-designated products, TI will not be responsible for any failure to meet ISO/TS16949.

Products

Audio	www.ti.com/audio
Amplifiers	amplifier.ti.com
Data Converters	dataconverter.ti.com
DLP® Products	www.dlp.com
DSP	dsp.ti.com
Clocks and Timers	www.ti.com/clocks
Interface	interface.ti.com
Logic	logic.ti.com
Power Mgmt	power.ti.com
Microcontrollers	microcontroller.ti.com
RFID	www.ti-rfid.com
OMAP Applications Processors	www.ti.com/omap
Wireless Connectivity	www.ti.com/wirelessconnectivity

Applications

Automotive and Transportation	www.ti.com/automotive
Communications and Telecom	www.ti.com/communications
Computers and Peripherals	www.ti.com/computers
Consumer Electronics	www.ti.com/consumer-apps
Energy and Lighting	www.ti.com/energy
Industrial	www.ti.com/industrial
Medical	www.ti.com/medical
Security	www.ti.com/security
Space, Avionics and Defense	www.ti.com/space-avionics-defense
Video and Imaging	www.ti.com/video

TI E2E Community

e2e.ti.com