

CURRENT MODE PWM CONTROLLER

- OPTIMIZED FOR OFF-LINE AND DC TO DC CONVERTERS
- LOW START-UP CURRENT (< 1 mA)
- AUTOMATIC FEED FORWARD COMPENSATION
- PULSE-BY-PULSE CURRENT LIMITING
- ENHANCED LOAD RESPONSE CHARACTERISTICS
- UNDER-VOLTAGE LOCKOUT WITH HYSTERESIS
- DOUBLE PULSE SUPPRESSION
- HIGH CURRENT TOTEM POLE OUTPUT
- INTERNALLY TRIMMED BANDGAP REFERENCE
- 500 KHz OPERATION
- LOW R_{O} ERROR AMP

tor which also provides current limit control, and a totem pole output stage designed to source or sink high peak current. The output stage, suitable for driving N-Channel MOSFETs, is low in the off-state.

Differences between members of this family are the under-voltage lockout thresholds and maximum duty cycle ranges. The UC1842 and UC1844 have UVLO thresholds of 16 V (on) and 10 V (off), ideally suited to off-line applications. The corresponding thresholds for the UC1843 and UC1845 are 8.5 V and 7.9 V. The UC1842 and UC1843 can operate to duty cycles approaching 100 %. A range of the zero to < 50 % is obtained by the UC1844 and UC1845 by the addition of an internal toggle flip flop which blanks the output off every other clock cycle.

DESCRIPTION

The UC1842/3/4/5 family of control ICs provides the necessary features to implement off-line or DC to DC fixed frequency current mode control schemes with a minimal external parts count. Internally implemented circuits include under voltage lockout featuring start-up current less than 1 mA, a precision reference trimmed for accuracy at the error amp input, logic to insure latched operation, a PWM compara-

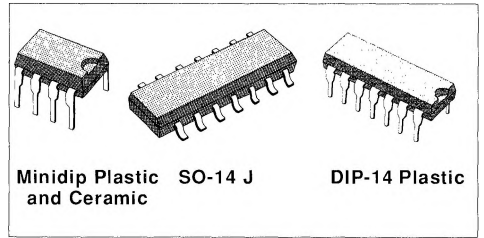

BLOCK DIAGRAM (toggle flip flop used only in UC1844 and UC1845)

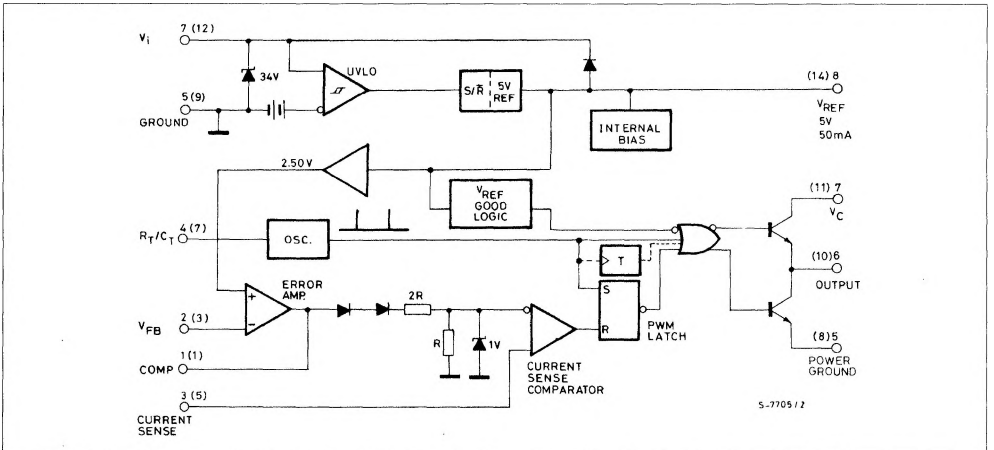

ABSOLUTE MAXIMUM RATINGS *

Symbol	Parameter	Value	Unit
V_i	Supply Voltage (low impedance source)	30	V
V_i	Supply Voltage ($I_i < 30$ mA)	Self Limiting	
I_o	Output Current	± 1	A
E_o	Output Energy (capacitive load)	5	μ J
	Analog Inputs (pins 2, 3)	- 0.3 to 6.3	V
	Error Amplifier Output Sink Current	10	mA
P_{tot}	Power Dissipation at $T_{amb} \leq 50$ °C (minidip, DIP-14)	1	W
P_{tot}	Power Dissipation at $T_{amb} \leq 25$ °C (SO-14)	725	mW
T_{stg}	Storage Temperature Range	- 65 to 150	°C
T_L	Lead Temperature (soldering 10 s)	300	°C

* All voltages are with respect to pin 5, all currents are positive into the specified terminal.

BLOCK DIAGRAM (top view)

DIP-14 / SO-14.

Minidip Plastic and Ceramic.

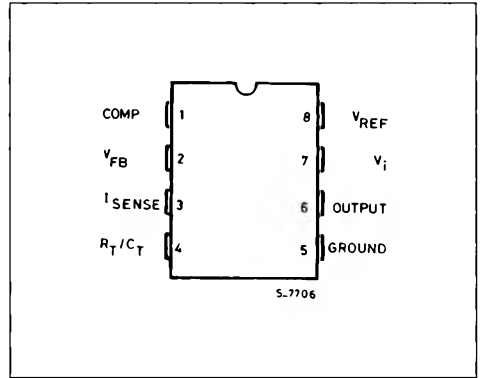
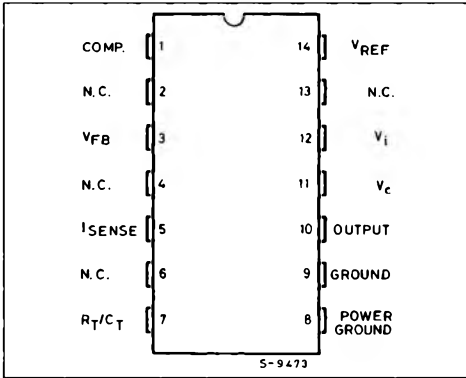

ORDERING NUMBERS

TYPE	PLASTIC MINIDIP	CERAMIC MINIDIP	DIP-14	SO-14
UC1842		UC1842J		
UC1843		UC1843J		
UC1844		UC1844J		
UC1845		UC1845J		
UC2842	UC2842N	UC2842J	UC2842B	UC2842D
UC2843	UC2843N	UC2843J	UC2843B	UC2843D
UC2844	UC2844N	UC2844J	UC2844B	UC2844D
UC2845	UC2845N	UC2845J	UC2845B	UC2845D
UC3842	UC3842N	UC3842J	UC3842B	UC3842D
UC3843	UC3843N	UC3843J	UC3843B	UC3843D
UC3844	UC3844N	UC3844J	UC3844B	UC3844D
UC3845	UC3845N	UC3845J	UC3845B	UC3845D

THERMAL DATA

		Ceramic Minidip	Plastic Minidip	DIP-14 Plastic	SO-14
$R_{th j-amb}$	Thermal Resistance Junction-ambient	200 °C/W	100 °C/W	100 °C/W	165 °C/W

ELECTRICAL CHARACTERISTICS (unless otherwise stated, these specifications apply for $-55 \leq T_{amb} \leq 125$ °C for UC184X ; $-25 \leq T_{amb} \leq 85$ °C for UC284X ; $0 \leq T_{amb} \leq 70$ °C for UC384X ; $V_i = 15$ V (Note 5) ; $R_T = 10$ K ; $C_T = 3.3$ nF)

Symbol	Parameter	Test Conditions	UC184X 284X			UC384X			Unit
			Min.	Typ.	Max.	Min.	Typ.	Max.	

REFERENCE SECTION

V_{REF}	Output Voltage	$T_j = 25$ °C $I_o = 1$ mA	4.95	5.00	5.05	4.90	5.00	5.10	V
ΔV_{REF}	Line Regulation	$12 \text{ V} \leq V_i \leq 25 \text{ V}$		6	20		6	20	mV
ΔV_{REF}	Load Regulation	$1 \leq I_o \leq 20$ mA		6	25		6	25	mV
$\Delta V_{REF}/\Delta T$	Temperature Stability	(Note 2)		0.2	0.4		0.2	0.4	mV/°C
	Total Output Variation	Line, Load, Temperature (Note 2)	4.9		5.1	4.82		5.18	V
e_N	Output Noise Voltage	$10 \text{ Hz} \leq f \leq 10 \text{ KHz}$ $T_j = 25$ °C (Note 2)		50			50		μ V
	Long Term Stability	$T_{amb} = 125$ °C, 1000 Hrs (Note 2)		5	25		5	25	mV
I_{sc}	Output Short Circuit		-30	-100	-180	-30	-100	-180	mA

OSCILLATOR SECTION

f_s	Initial Accuracy	$T_j = 25$ °C (Note 6)	47	52	57	47	52	57	KHz
	Voltage Stability	$12 \leq V_i \leq 25$ V		0.2	1		0.2	1	%
	Temperature Stability	$T_{MIN} \leq T_{amb} \leq T_{MAX}$ (Note 2)		5			5		%
V_4	Amplitude	V_{PIN4} Peak to Peak		1.7			1.7		V

ERROR AMP SECTION

V_2	Input Voltage	$V_{PIN1} = 2.5$ V	2.45	2.50	2.55	2.42	2.50	2.58	V
I_b	Input Bias Current			-0.3	-1		-0.3	-2	μ A
	A_{VOL}	$2 \leq V_o \leq 4$ V	65	90		65	90		dB
B	Unity Gain Bandwidth	(Note 2)	0.7	1		0.7	1		MHz
SVR	Supply Voltage Rejection	$12 \leq V_i \leq 25$ V	60	70		60	70		dB
I_o	Output Sink Current	$V_{PIN2} = 2.7$ V $V_{PIN1} = 1.1$ V	2	6		2	6		mA
I_o	Output Source Current	$V_{PIN2} = 2.3$ V $V_{PIN1} = 5$ V	-0.5	-0.8		-0.5	-0.8		mA
	V_{OUT} High	$V_{PIN2} = 2.3$ V ; $R_L = 15$ K Ω to Ground	5	6		5	6		V
	V_{OUT} Low	$V_{PIN2} = 2.7$ V ; $R_L = 15$ K Ω to Pin 8		0.7	1.1		0.7	1.1	V

ELECTRICAL CHARACTERISTICS (continued)

Symbol	Parameter	Test Conditions	UC184X UC284X			UC384X			Unit
			Min.	Typ.	Max.	Min.	Typ.	Max.	

CURRENT SENSE SECTION

G_v	Gain	(Notes 3 & 4)	2.85	3	3.15	2.8	3	3.2	V/V
V_3	Maximum Input Signal	$V_{PIN1} = 5\text{ V}$ (Note 3)	0.9	1	1.1	0.9	1	1.1	V
SVR	Supply Voltage Rejection	$12 \leq V_i \leq 25\text{ V}$ (Note 3)		70			70		dB
I_b	Input Bias Current			- 2	- 10		- 2	- 10	μA
	Delay to Output			150	300		150	300	ns

OUTPUT SECTION

I_{OL}	Output Low Level	$I_{SINK} = 20\text{ mA}$		0.1	0.4		0.1	0.4	V
		$I_{SINK} = 200\text{ mA}$		1.5	2.2		1.5	2.2	
I_{OH}	Output High Level	$I_{SOURCE} = 20\text{ mA}$	13	13.5		13	13.5		V
		$I_{SOURCE} = 200\text{ mA}$	12	13.5		12	13.5		
t_r	Rise Time	$T_j = 25\text{ }^\circ\text{C}$ $C_L = 1\text{ nF}$ (Note 2)		50	150		50	150	ns
t_f	Fall Time	$T_j = 25\text{ }^\circ\text{C}$ $C_L = 1\text{ nF}$ (Note 2)		50	150		50	150	ns

UNDER-VOLTAGE LOCKOUT SECTION

	Start Threshold	X842/4	15	16	17	14.5	16	17.5	V
		X843/5	7.8	8.4	9.0	7.8	8.4	9.0	
	Min. Operating Voltage After Turn-on	X842/4	9	10	11	8.5	10	11.5	V
		X843/5	7.0	7.6	8.2	7.0	7.6	8.2	

PWM SECTION

	Maximum Duty Cycle	X842/3	93	97	100	93	97	100	%
		X844/5	44	48	50	45	48	50	
	Minimum Duty Cycle				0			0	%

TOTAL STANDBY CURRENT

I_{st}	Start-up Current			0.5	1		0.5	1	mA
I_i	Operating Supply Current	$V_{PIN2} = V_{PIN3} = 0\text{ V}$		11	20		11	20	mA
V_{iz}	Zener Voltage	$I_i = 25\text{ mA}$		34			34		V

Notes : 2. These parameters, although guaranteed, are not 100% tested in production.

3. Parameter measured at trip point of latch with $V_{PIN2} = 0$.

4. Gain defined as :

$$A = \frac{\Delta V_{PIN1}}{\Delta V_{PIN3}}; 0 \leq V_{PIN3} \leq 0.8\text{ V}$$

5. Adjust V_i above the start threshold before setting at 15 V.

6. Output frequency equals oscillator frequency for the UC1842 and UC1843.

Output frequency is one half oscillator frequency for the UC1844 and UC1845.

Figure 1 : Error Amp Configuration.

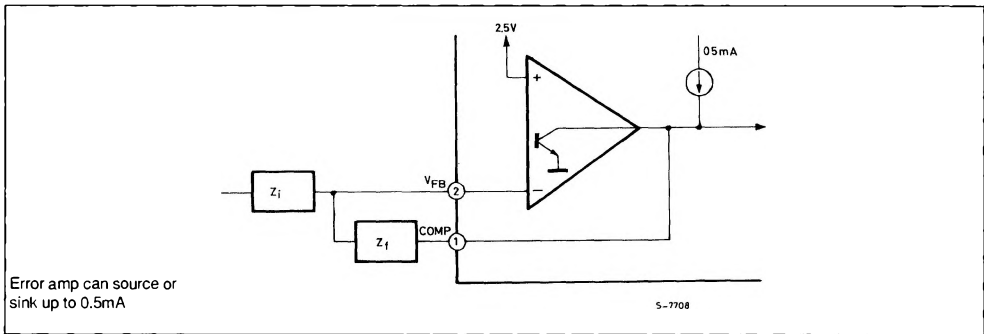
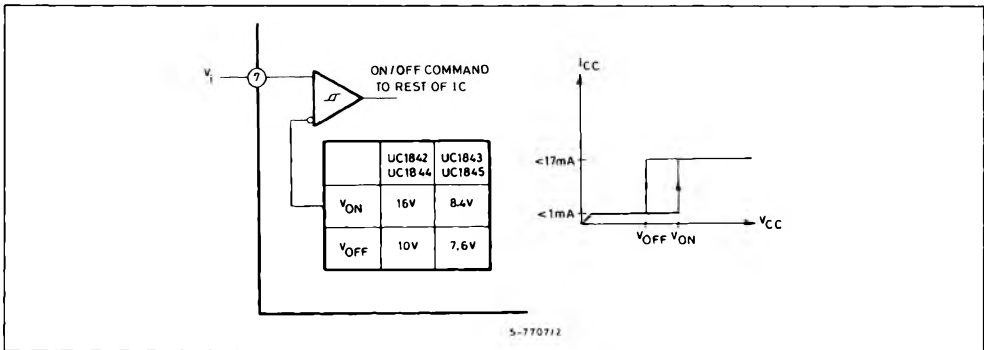

Figure 2 : Under Voltage Lockout.



During Under-Voltage Lockout, the output driver is biased to sink minor amounts of current. Pin 6 should be shunted to ground with a bleeder resistor

to prevent activating the power switch with extraneous leakage currents.

Figure 3 : Current Sense Circuit .

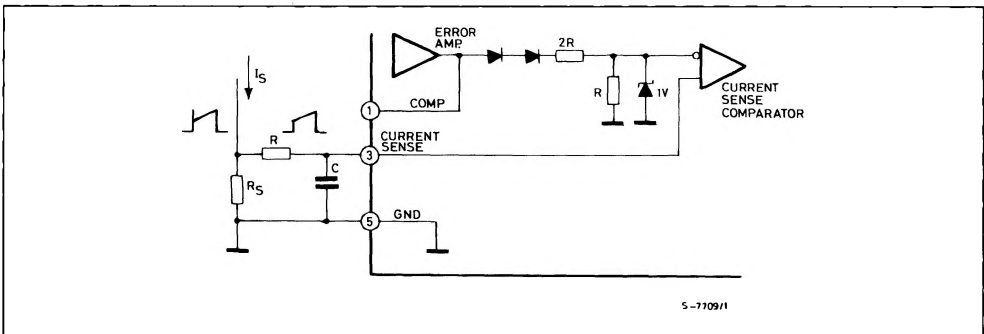

PEAK CURRENT (I_S) IS DETERMINED BY THE FORMULA

$$I_{S \max} \approx \frac{1.0 \text{ V}}{R_S}$$

A SMALL RC FILTER MAY BE REQUIRED TO SUPPRESS SWITCH TRANSIENTS.

Figure 4.

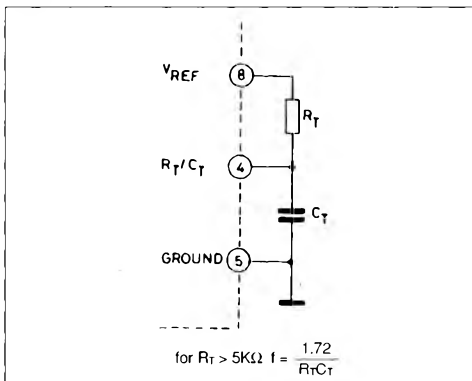

Figure 5 : Deadtime vs. C_T ($R_T > 5K\Omega$).

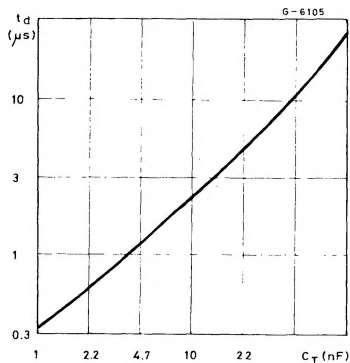

Figure 6 : Timing Resistance vs. Frequency.

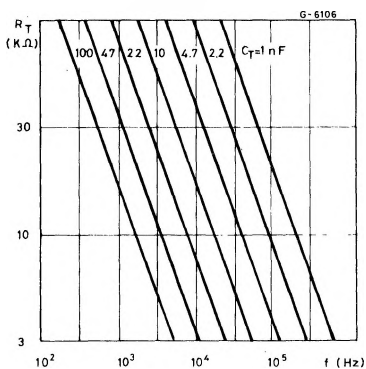

Figure 7 : Output Saturation Characteristics.

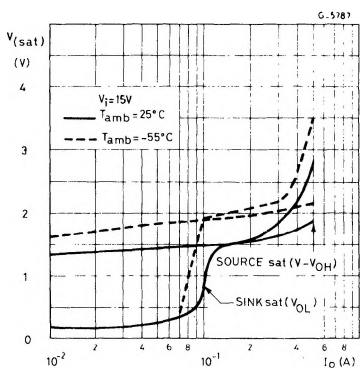

Figure 8 : Error Amplifier Open-loop Frequency Response.

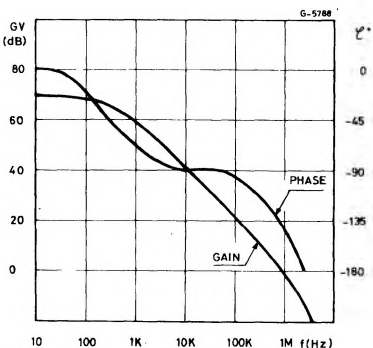
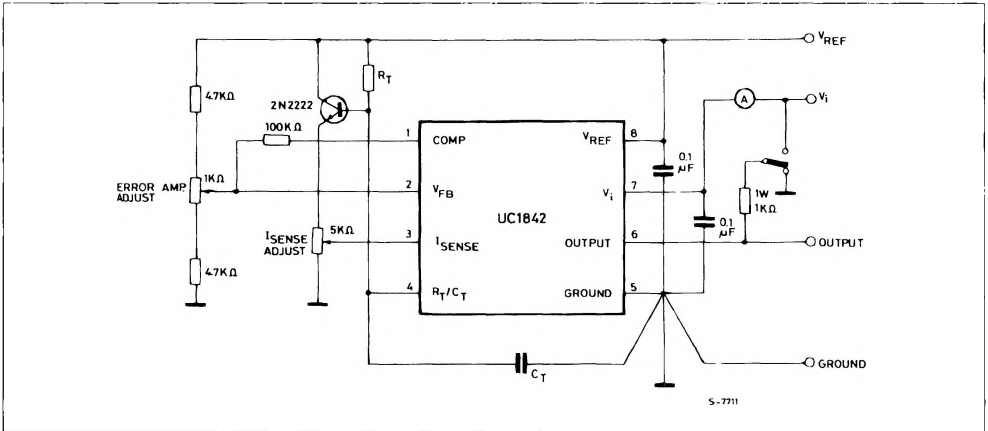

Figure 9 : Open Loop Test Circuit.



High peak currents associated with capacitive loads necessitate careful grounding techniques. Timing and bypass capacitors should be connected close

to pin 5 in a single point ground. The transistor and 5 KΩ potentiometer are used to sample the oscillator waveform and apply an adjustable ramp to pin 3.

Figure 10 : Shutdown Techniques.

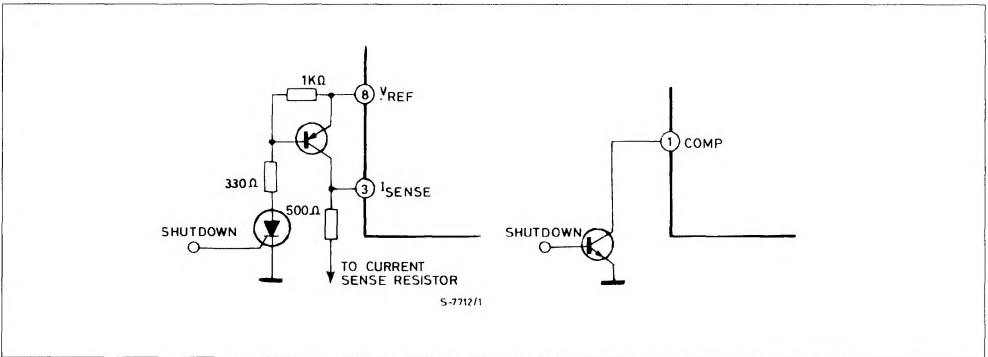

Shutdown of the UC1842 can be accomplished by two methods ; either raise pin 3 above 1V or pull pin 1 below a voltage two diode drops above ground. Either method cause the output of the PWM comparator to be high (refer to block diagram). The PWM latch is reset dominant so that the output will remain low until the next clock cycle after the shut-

down condition at pins 1 and/or 3 is removed. In one example, an externally latched shutdown may be accomplished by adding an SCR which will be reset by cycling V_i below the lower UVLO threshold. At this point the reference turns off, allowing the SCR to reset.

Figure 11 : Off-line Flyback Regulator.

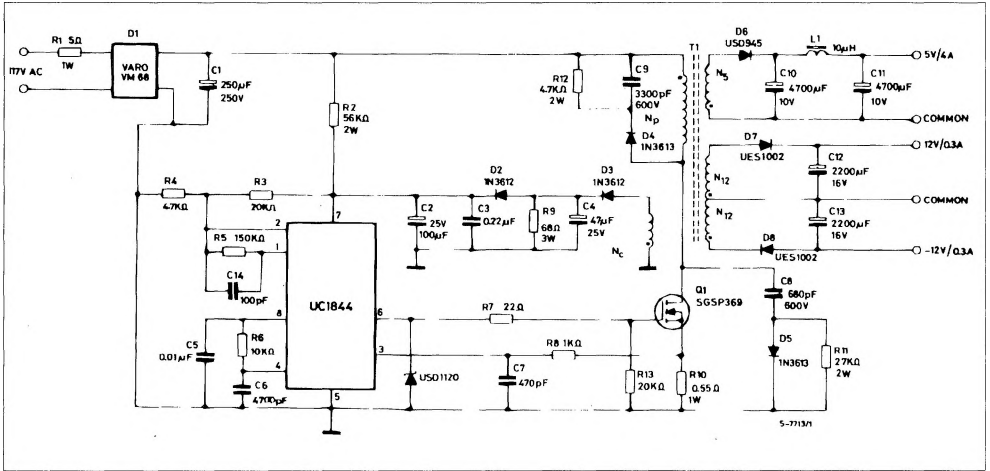

Power Supply Specifications

- | | |
|--|--|
| <p>1. Input Voltage : 95 VAC to 130 VAC
(50 Hz/60 Hz)</p> <p>2. Line Isolation : 3750 V</p> <p>3. Switching Frequency : 40 KHz</p> <p>4. Efficiency @ Full Load : 70 %</p> | <p>5. Output Voltage :</p> <p>A. + 5 V, $\pm 5\%$: 1 A to 4 A load
Ripple voltage : 50 mV P-P Max.</p> <p>B. + 12 V, $\pm 3\%$: 0.1 A to 0.3 A load
Ripple voltage : 100 mV P-P Max.</p> <p>C. - 12 V, $\pm 3\%$: 0.1 A to 0.3 A load
Ripple voltage : 100 mV P-P Max.</p> |
|--|--|

Figure 12 : Slope Compensation.

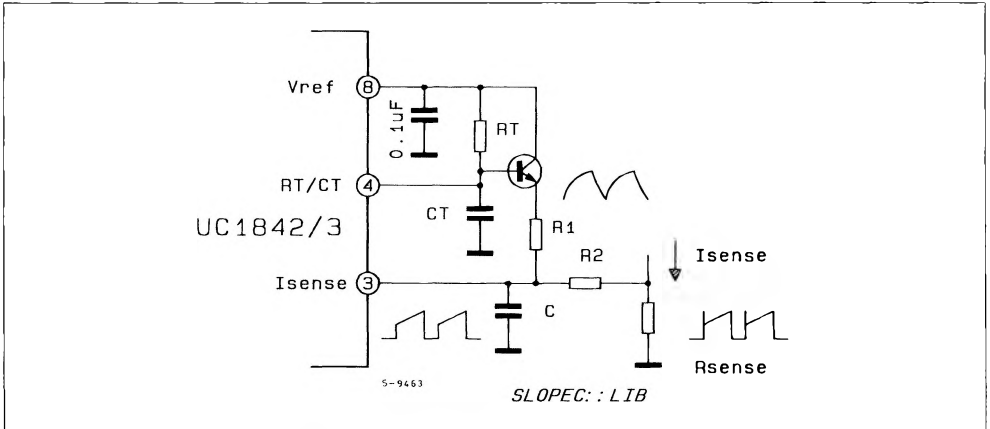

A fraction of the oscillator ramp can be resistively summed with the current sense signal to provide slope compensation for converters requiring duty cycles over 50 %.

Note that capacitor, C, forms a filter with R₂ to suppress the leading edge switch spikes.