

GENERAL PURPOSE SINGLE OP-AMPS

- FREQUENCY COMPENSATION WITH A SINGLE 30 pF CAPACITOR
- OPERATION FROM ± 5 V TO ± 15 V
- LOW POWER CONSUMPTION : 50 mW AT ± 15 V
- CONTINUOUS SHORT-CIRCUIT PROTECTION
- OPERATION AS A COMPARATOR WITH DIFFERENTIAL INPUTS AS HIGH AS ± 30 V
- NO LATCH-UP WHEN COMMON-MODE RANGE IS EXCEEDED
- SAME PIN CONFIGURATION AS THE LM101A

tible with logic circuits. Further, the low power dissipation permits high voltage operation and simplifies packaging in full-temperature range systems.

DESCRIPTION

The UA748 is a general-purpose operational amplifier built on a single silicon chip. The resulting close match and tight thermal coupling gives low offsets and temperature drift as well as fast recovery from thermal transients.

- Short-circuit protection.
- Offset voltage null capability.
- Large common-mode and differential voltage ranges.
- Low power consumption.
- No latch-up

The unity-gain compensation specified makes the circuit stable for all feedback configurations, even with capacitive loads. However, it is possible to optimize compensation for best high frequency performance at any gain. As a comparator the output can be clamped at any desired level to make it compa-

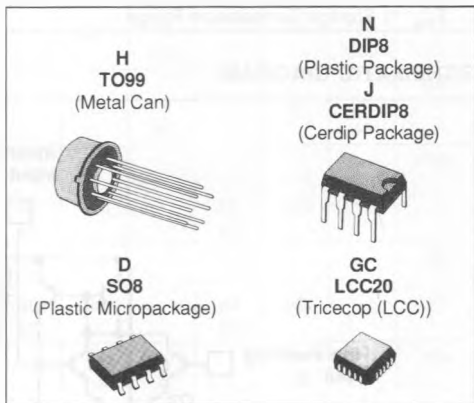

ORDER CODES

Part Number	Temperature Range	Package			
		H	N	GC	D
UA748C	0 °C to + 70 °C	•	•		•
UA748I	40 °C to + 105 °C	•	•		•
UA748M	- 55 °C to + 125 °C	•		•	

Note : Hi-rel Versions Available
Examples : UA748CH, UA748MGC

PIN CONNECTIONS (top views)

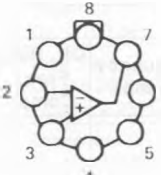
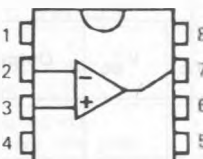
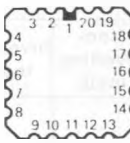
TO99	DIP8 CERDIP8, SO8	LCC20	
			5 - Inverting input
1 - Offset null frequency compensation	5 - Offset null	1 - NC	6 - NC
2 - Inverting input	6 - Output	2 - Offset null frequency compensation	7 - Non-inverting input
3 - Non-inverting input	7 - V _{cc}	3 - NC	8 - NC
4 - V _{cc}	8 - Frequency compensation	4 - NC	9 - NC
	E88UA748.D1	5 - 18	10 - V _{cc}
		6 - 17	11 - NC
		7 - 16	12 - Offset null
		8 - 15	13 - NC
		9 - 14	14 - NC
		10 - 13	15 - Output
		11 - 12	16 - NC
		12 - 11	17 - V _{cc}
		13 - 10	18 - NC
		14 - 9	19 - NC
		15 - 8	20 - Frequency compensation

ABSOLUTE MAXIMUM RATINGS

Symbol	Parameter	UA748M	UA748I	UA748C	Unit
V_{CC}	Supply Voltage	± 22	± 22	± 22	V
V_I	Input Voltage	± 15	± 15	± 15	V
V_{ID}	Differential Input Voltage	± 30	± 30	± 30	V
P_{Tot}	Power Dissipation	500	500	500	mW
		GC Suffix		300	
	Output Short-circuit Duration	Infinite for $T_{amb} = 70\text{ }^\circ\text{C}$		Infinite for $T = 55\text{ }^\circ\text{C}$	
T_{oper}	Operating Free Air Temperature Range	-55 to $+125$	-40 to $+105$	0 to $+70$	$^\circ\text{C}$
T_{sig}	Storage Temperature Range	-65 to $+150$	-65 to $+150$	-65 to $+150$	$^\circ\text{C}$

SCHEMATIC DIAGRAM

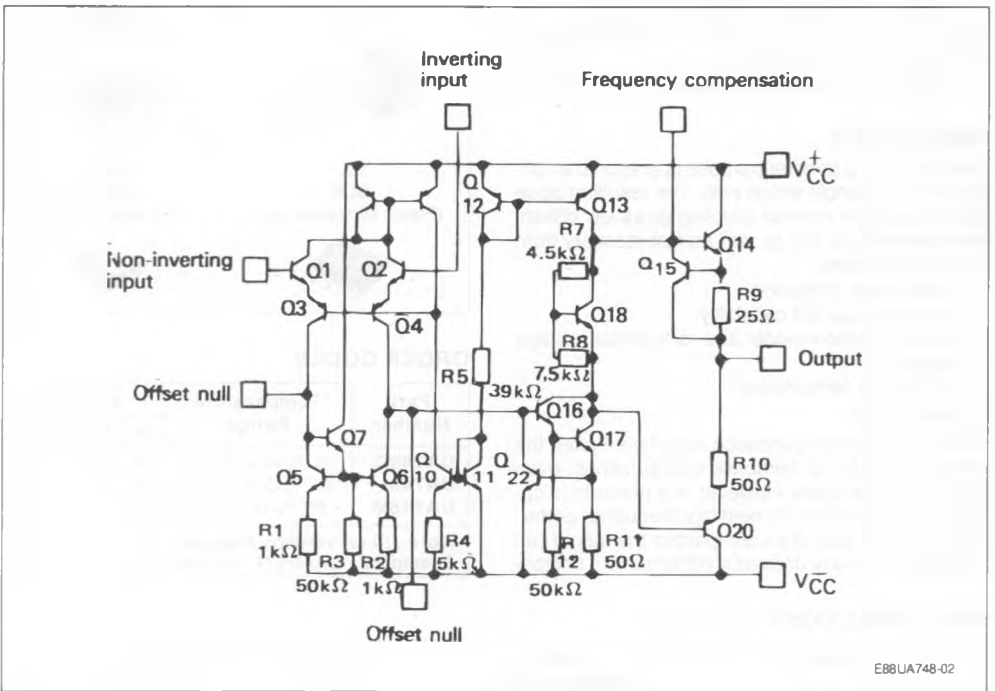

Case	Offset Null	Non-inverting Input	Inverting Input	V_{-CC}	V_{+CC}	Output	Frequency Comp.	Off. Null. Freq. Comp.	N.C.
TO99 DIP8 CERDIP8 SO8	5	3	2	4	7	6	8	1	
LCC20 *	12	7	5	10	17	1	5	20	2

* LCC20 : Other pins are not connected.

ELECTRICAL CHARACTERISTICS

UA748C : $0\text{ }^{\circ}\text{C} < T_{\text{amb}} < +70\text{ }^{\circ}\text{C}$ $\pm 5\text{ V} < V_{\text{CC}} < \pm 20\text{ V}$ C1 = 30 pFUA748I : $-40\text{ }^{\circ}\text{C} < T_{\text{amb}} < +105\text{ }^{\circ}\text{C}$ $\pm 5\text{ V} < V_{\text{CC}} < \pm 20\text{ V}$ C1 = 30 pFUA748M : $-55\text{ }^{\circ}\text{C} < T_{\text{amb}} < +125\text{ }^{\circ}\text{C}$ $\pm 5\text{ V} < V_{\text{CC}} < \pm 20\text{ V}$ C1 = 30 pF* $\Rightarrow V_{\text{CC}} = \pm 15\text{ V}$

(unless otherwise specified)

Symbol	Parameter	UA748M, I			UA748C			Unit
		Min.	Typ.	Max.	Min.	Typ.	Max.	
V_{IO}	Input Offset Voltage $R_{\text{S}} \leq 10\text{ k}\Omega$ $T_{\text{amb}} = 25\text{ }^{\circ}\text{C}$ $T_{\text{min}} \leq T_{\text{amb}} \leq T_{\text{max}}$		0.2	1 3		2	5 6	mV
I_{IB}	Input Bias Current $T_{\text{amb}} = 25\text{ }^{\circ}\text{C}$ $T_{\text{min}} \leq T_{\text{amb}} \leq T_{\text{max}}$		25	75 100		70	100 200	nA
I_{IO}	Input Offset Current $T_{\text{amb}} = 25\text{ }^{\circ}\text{C}$ $T_{\text{min}} \leq T_{\text{amb}} \leq T_{\text{max}}$		1.5	10 20		2	20 40	nA
A_{VD}	Large Signal Voltage Gain * ($V_{\text{O}} = \pm 10\text{ V}$, $R_{\text{L}} = 2\text{ k}\Omega$) $T_{\text{amb}} = 25\text{ }^{\circ}\text{C}$ $T_{\text{min}} \leq T_{\text{amb}} \leq T_{\text{max}}$	50 25	100		50 25	100		V/mV
SVR	Supply Voltage Rejection Ratio ($R_{\text{S}} < 10\text{ k}\Omega$) $T_{\text{amb}} = 25\text{ }^{\circ}\text{C}$ $T_{\text{min}} \leq T_{\text{amb}} \leq T_{\text{max}}$	80 80	96		80 80	96		dB
I_{CC}	Supply Current, no Load $T_{\text{amb}} = 25\text{ }^{\circ}\text{C}$ $T_{\text{min}} \leq T_{\text{amb}} \leq T_{\text{max}}$		1.8	3 3		1.8	3 3	mA
V_{I}	Input Voltage Range ($V_{\text{CC}} = \pm 20\text{ V}$) $T_{\text{amb}} = 25\text{ }^{\circ}\text{C}$ $T_{\text{min}} \leq T_{\text{amb}} \leq T_{\text{max}}$	-15 -15		+15 +15	-15 -15		+15 +15	V
CMR	Common-mode Rejection Ratio ($R_{\text{S}} \leq 10\text{ k}\Omega$) $T_{\text{amb}} = 25\text{ }^{\circ}\text{C}$ $T_{\text{min}} \leq T_{\text{amb}} \leq T_{\text{max}}$	80 80	96		80 80	96		dB
I_{OS}	Output Short-circuit Current * $T_{\text{amb}} = 25\text{ }^{\circ}\text{C}$	10	30	50	10	30	50	mA
$\pm V_{\text{OPP}}$	Output Voltage Swing * $T_{\text{amb}} = 25\text{ }^{\circ}\text{C}$ $T_{\text{min}} \leq T_{\text{amb}} \leq T_{\text{max}}$							V
	$R_{\text{L}} = 10\text{ k}\Omega$	12	14		12	14		
	$R_{\text{L}} = 2\text{ k}\Omega$	10	13		10	13		
	$R_{\text{L}} = 10\text{ k}\Omega$	12			12			
	$R_{\text{L}} = 2\text{ k}\Omega$	10			10			
S_{VO}	Slew-rate ($V_{\text{I}} = \pm 10\text{ V}$, $R_{\text{L}} = 2\text{ k}\Omega$, $C_{\text{L}} \leq 100\text{ pF}$, $T_{\text{amb}} = 25\text{ }^{\circ}\text{C}$, unity gain) *	0.25	0.5		0.25	0.5		V/ μs
t_{r}	Rise Time * ($V_{\text{I}} = \pm 20\text{ mV}$, $R_{\text{L}} = 2\text{ k}\Omega$, $C_{\text{L}} \leq 100\text{ pF}$, $T_{\text{amb}} = +25\text{ }^{\circ}\text{C}$, unity gain)		0.3			0.3		μs
K_{OV}	Overshoot ($V_{\text{I}} = 20\text{ mV}$, $R_{\text{L}} = 2\text{ k}\Omega$, $C_{\text{L}} \leq 100\text{ pF}$, $T_{\text{amb}} = +25\text{ }^{\circ}\text{C}$, unity gain)		5			5		%
Z_{I}	Input Impedance, $T_{\text{amb}} = 25\text{ }^{\circ}\text{C}$ *	1.5	4		1.5	4		M Ω
R_{O}	Output Resistance, $T_{\text{amb}} = 25\text{ }^{\circ}\text{C}$ *		75			75		Ω

ELECTRICAL CHARACTERISTICS (continued)

Symbol	Parameter	UA748M, I			UA748C			Unit
		Min.	Typ.	Max.	Min.	Typ.	Max.	
GBP	Gain Bandwidth Product * ($V_i = 10 \text{ mV}$, $R_L = 2 \text{ k}\Omega$, $C_L \leq 100 \text{ pF}$, $f = 100 \text{ KHz}$, $T_{\text{amb}} = 25^\circ\text{C}$)	0.5	1	1.6	0.5	1	1.6	MHz
THD	Total Harmonic Distortion * ($f = 1 \text{ KHz}$, $A_V = 20 \text{ dB}$, $R_L = 2 \text{ k}\Omega$, $V_O = 2 V_{PP}$, $C_L \leq 100 \text{ pF}$, $T_{\text{amb}} = 25^\circ\text{C}$)		0.015			0.015		%
V_n	Equivalent Input Noise Voltage ($f = 1 \text{ KHz}$, $R_g = 100 \Omega$) *		25			25		$\text{nV}/\sqrt{\text{Hz}}$
DV_{IO}	Input Offset Voltage Drift $T_{\text{min}} \leq T_{\text{amb}} \leq T_{\text{max}}$		3	15		6	30	$\mu\text{V}/^\circ\text{C}$
DI_{IO}	Input Offset Current Drift $25^\circ\text{C} \leq T_{\text{amb}} \leq T_{\text{max}}$ $T_{\text{min}} \leq T_{\text{amb}} < 25^\circ\text{C}$		10 20	100 200		10 20	100 200	$\text{pA}/^\circ\text{C}$

CURRENT LIMITING

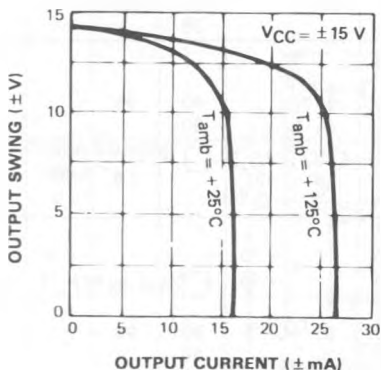

E88UA748-03

INPUT CURRENT

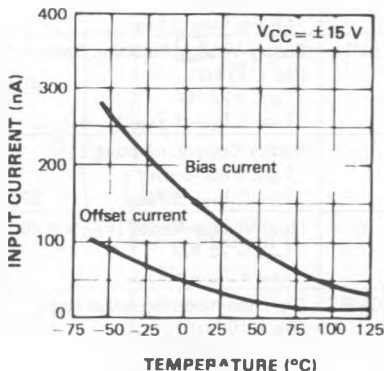

E88UA748-04

OPEN LOOP FREQUENCY RESPONSE

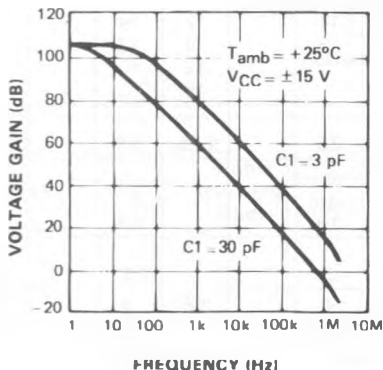

E88UA748-05

LARGE SIGNAL FREQUENCY RESPONSE

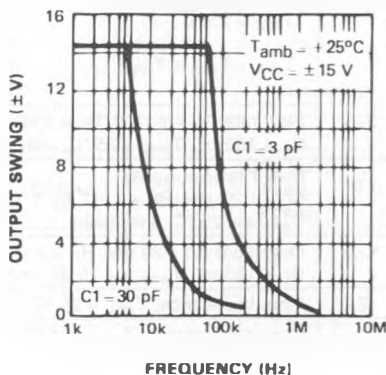

E88UA748-06

FREQUENCY COMPENSATION

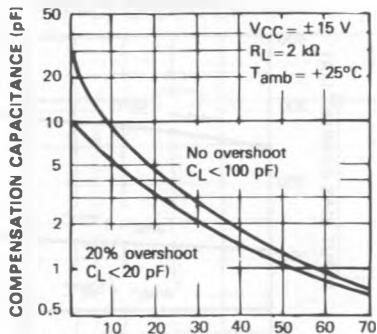

VOLTAGE FOLLOWER PULSE RESPONSE

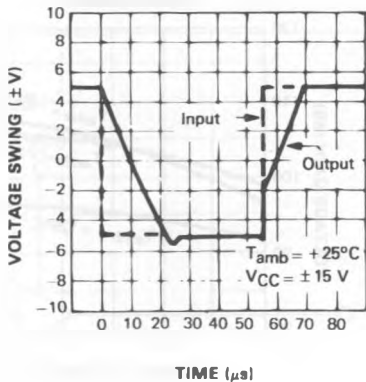

CLOSED LOOP VOLTAGE GAIN (dB)

E88UA748-07

E88UA748-08

INPUT VOLTAGE RANGE

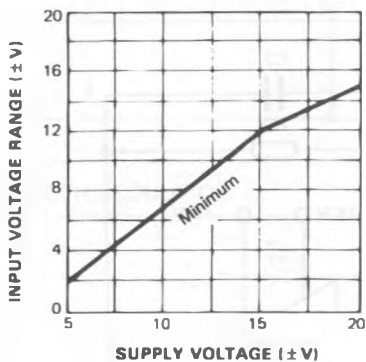

E88UA748-09

OUTPUT SWING

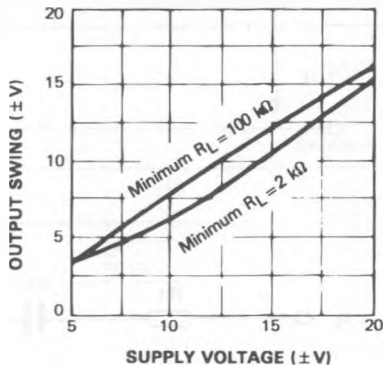

E88UA748-10

VOLTAGE GAIN

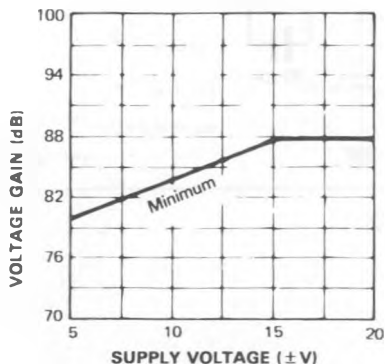

E88UA748-11

SUPPLY CURRENT

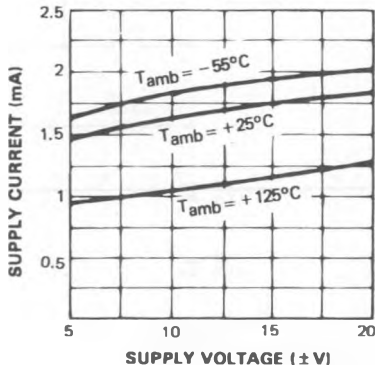

E88UA748-12

VOLTAGE GAIN

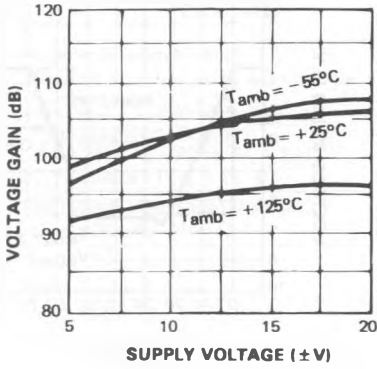

E88UA748-13

INPUT BIAS CURRENT

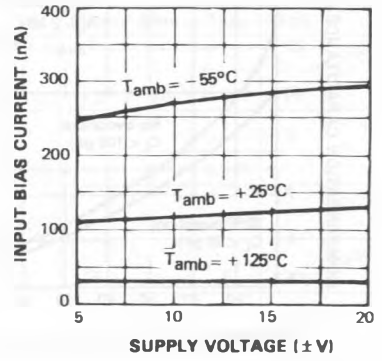

E88UA748-14

TYPICAL APPLICATIONS

PRACTICAL DIFFERENTIATOR

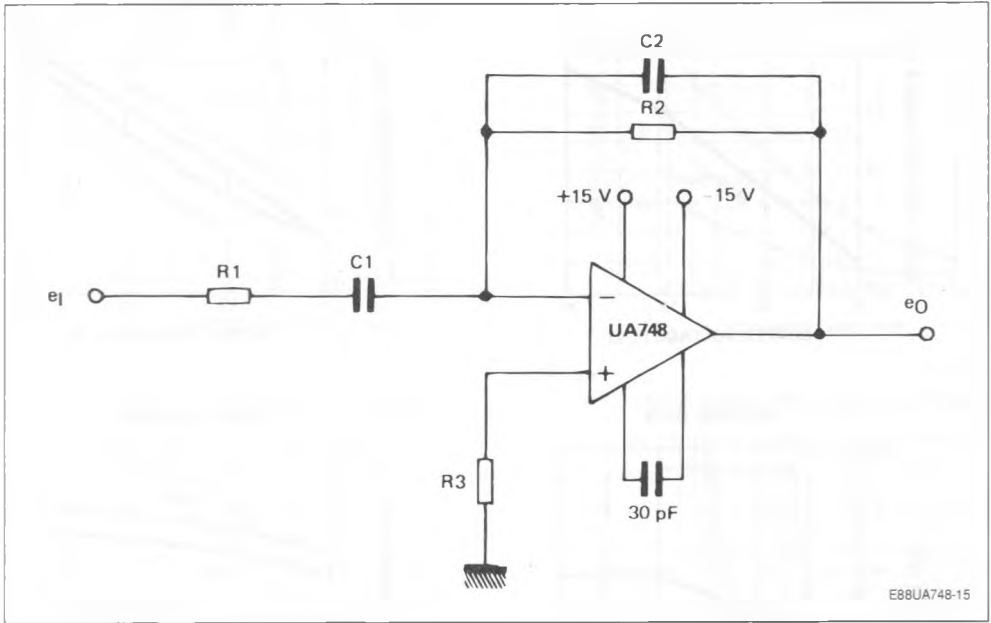

E88UA748-15

TYPICAL APPLICATIONS (continued)

SINGLE SUPPLY OPERATION

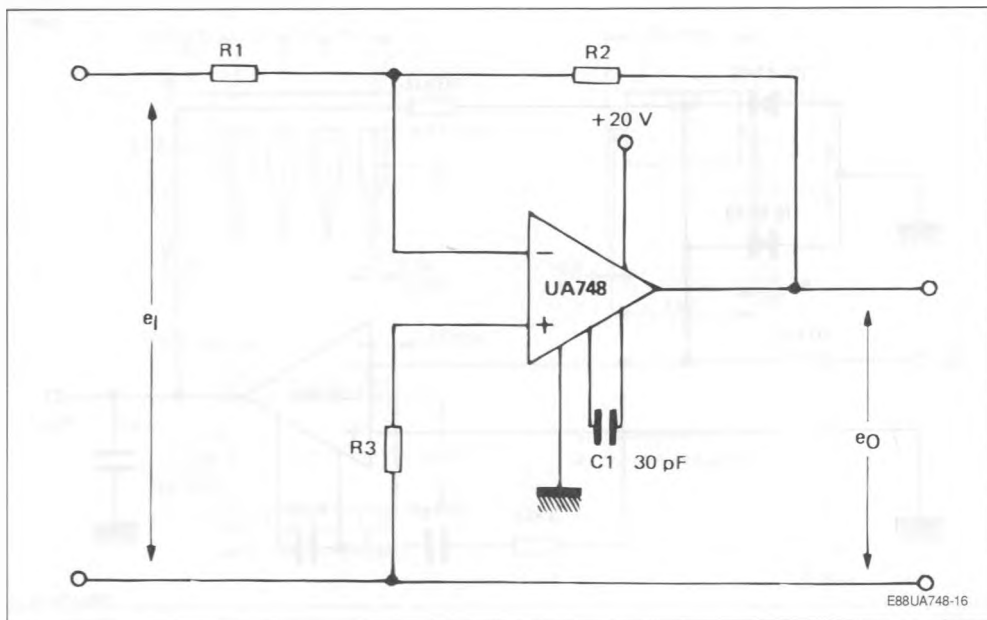

PULSE WIDTH MODULATOR

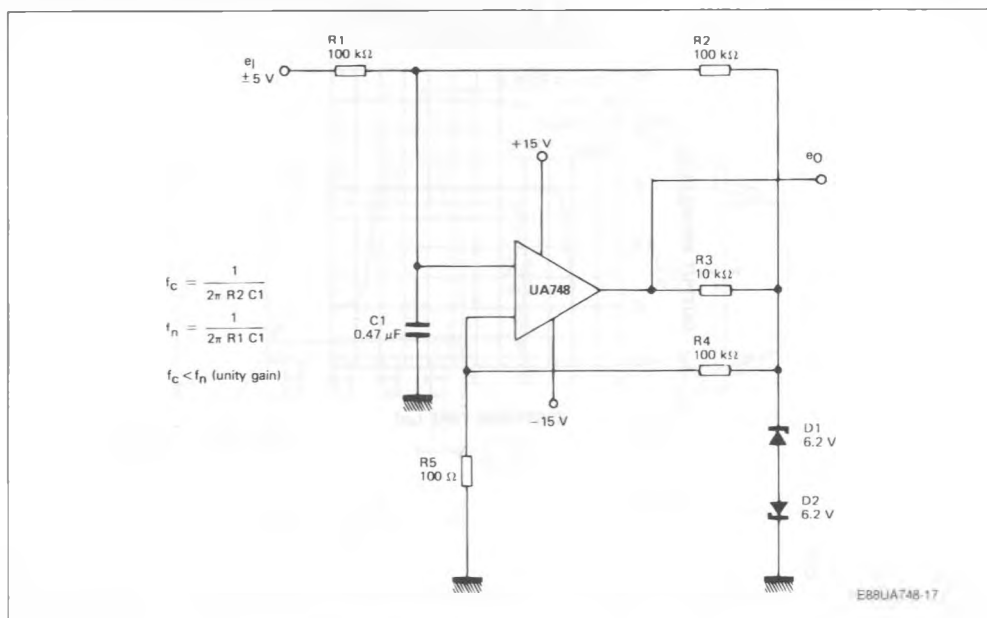

TYPICAL APPLICATIONS (continued)

FEED-FORWARD COMPENSATION

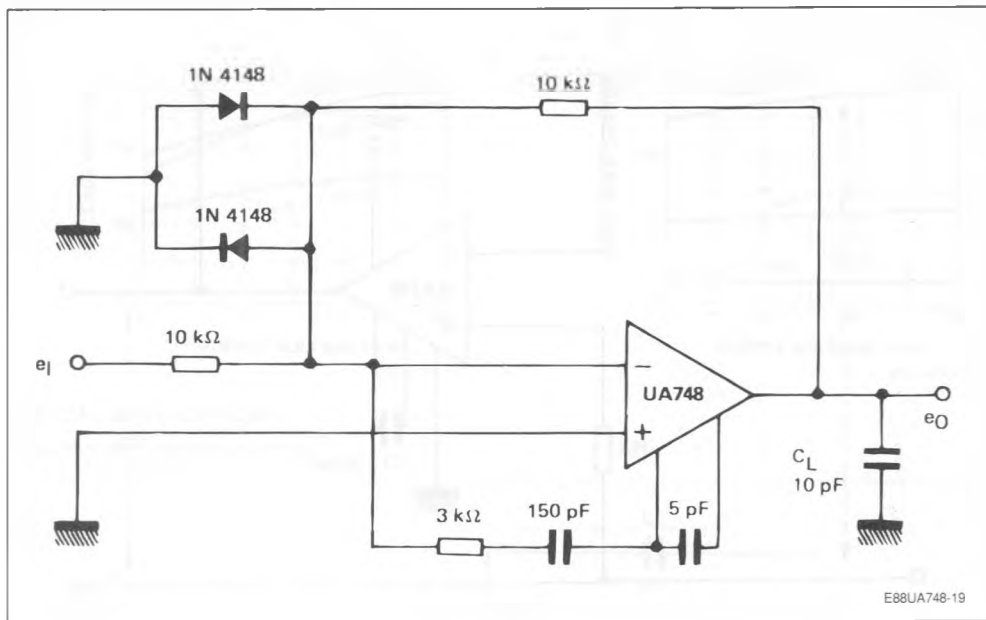

E88UA748-19

LARGE SIGNAL FEED-FORWARD
TRANSIENT RESPONSE

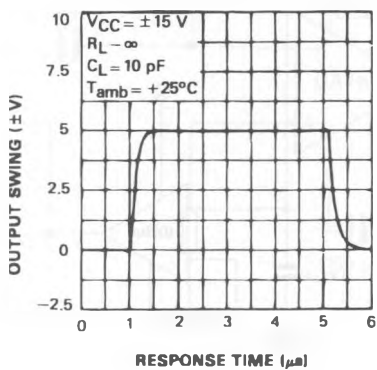

E88UA748-18

PACKAGE MECHANICAL DATA

8 PINS - PLASTIC DIP OR CERDIP

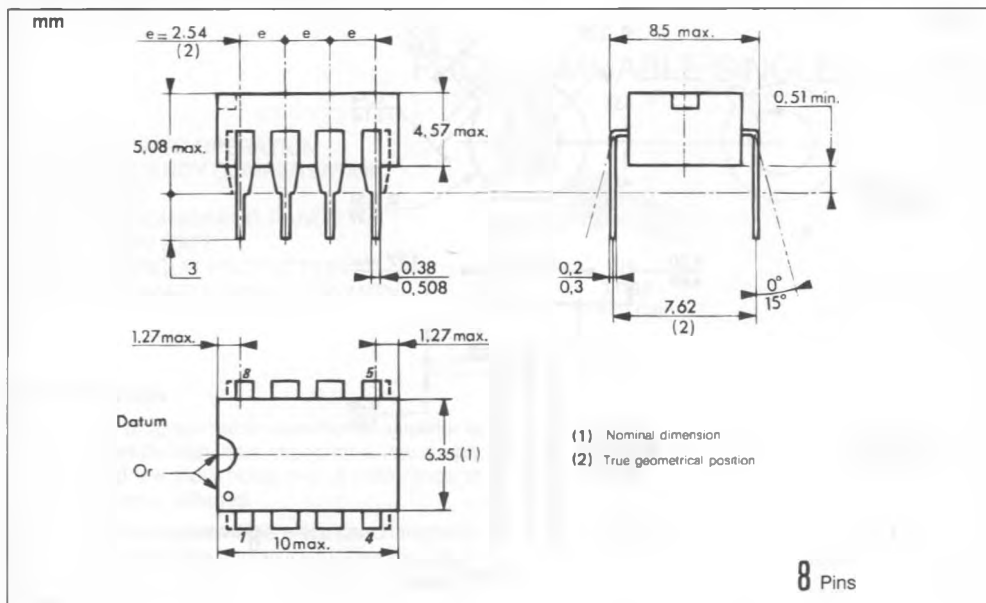

8 PINS - PLASTIC MICROPACKAGE (SO)

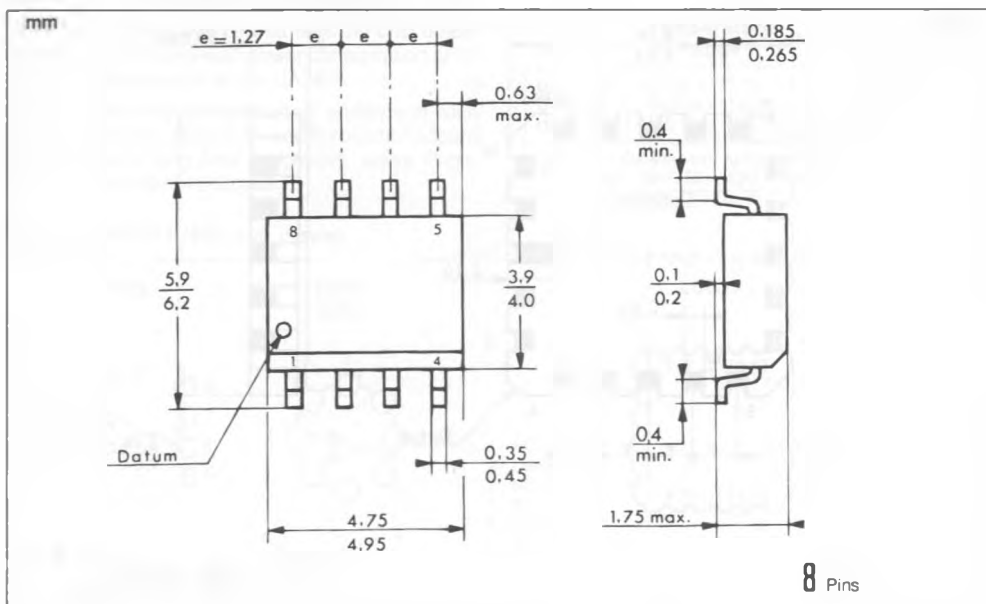

PACKAGE MECHANICAL DATA (continued)

8 PINS - METAL CAN TO99

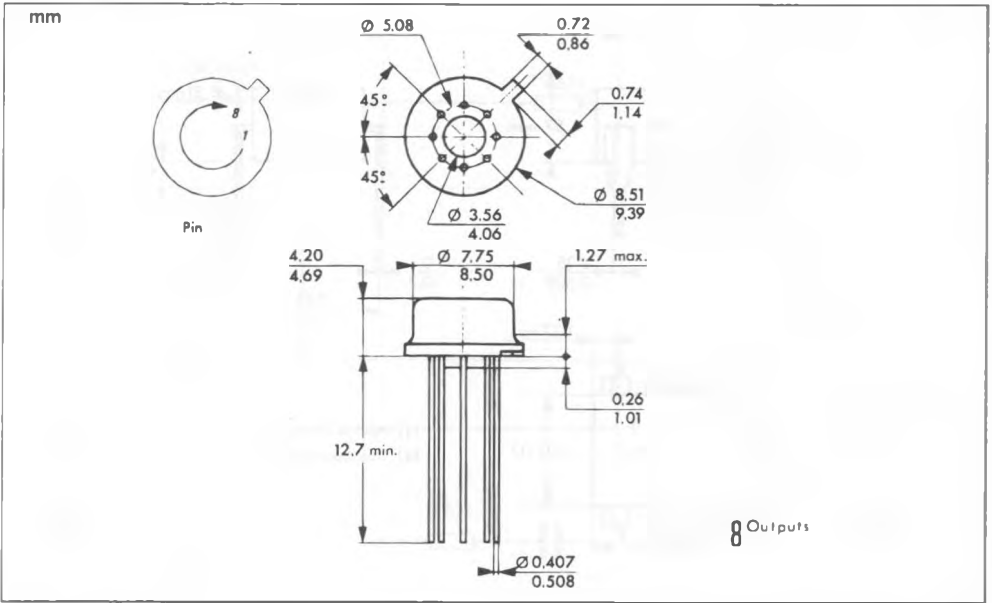

20 PINS - TRICOP (LCC)

