

IF System and I/Q Demodulator for Digital Satellite TV Transmissions

Description

The U6101B is a monolithic integrated circuit in TEMIC's UHF 5 technology for **Satellite Digital Video Broadcasting (DVBS)** and other digital direct satellite service applications. The circuit operates in a wide frequency range and in a large input level range.

Implemented are two orthogonal mixer stages (precise phase-matched by a control loop), a gain-controlled IF amplifier of high input sensitivity with two switchable

isolated inputs, and an AGC-system for tuner and IF level control. Alternatively the output level may be controlled automatically, e.g., via the channel decoder AGC signal output.

The local oscillator operates at IF input frequency. The oscillator signal is internally doubled and divided again to generate the orthogonal mixer driving signals.

Features

- Frequency range from 390 to 520 MHz
- Two unbalanced switchable inputs
- High I/Q phase accuracy, based on TEMIC's patented 0°/90° control loop circuit
- Input impedance 50 Ω, gain independent
- High input sensitivity
- AGC control range -35 dB
- Internal AGC detector
- Additionally external gain control and output level setting possible

Benefits

- Two switchable IF-inputs to connect a combined SAW filter
- Oscillator for SAW or LC tank circuit
- Adjustable tuner AGC control
- Low impedance output driver
- Balanced prescaler output
- Output signal level adjustable or fixed at typical or minimum data sheet value by pin programming
- Low power consumption, 5-V supply voltage

Ordering Information

Extended Type Number	Package	Remarks
U6101B-AFSG3	SSO20	Taped and reeled

Block Diagram

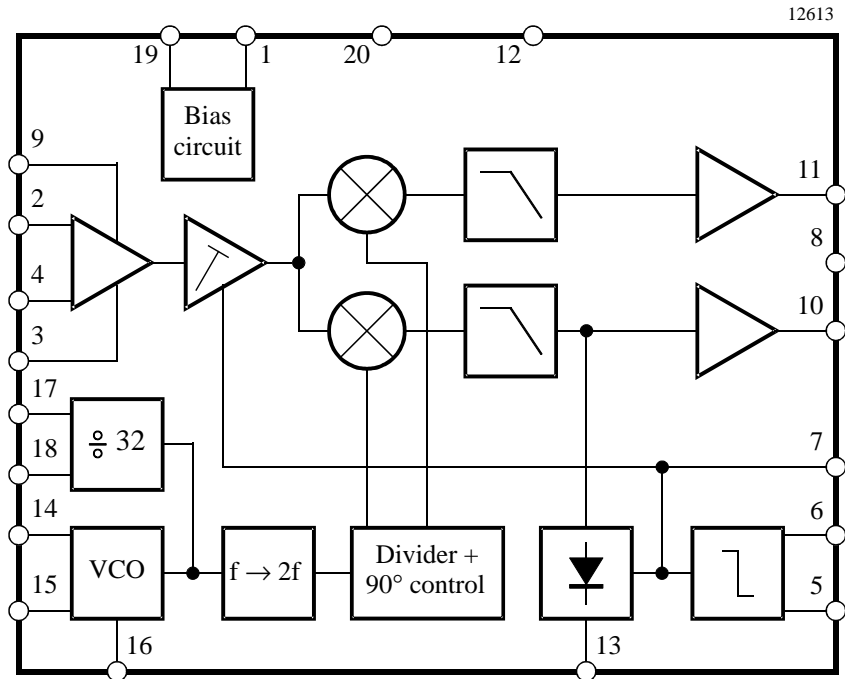
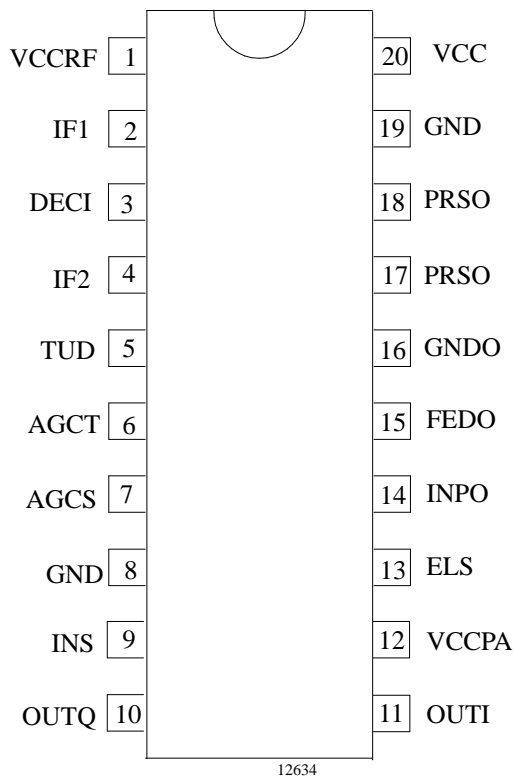

Figure 1.

Pin Description



Pin	Symbol	Function
1	VCCRF	RF supply voltage
2	IF1	IF input 1
3	DECI	Input decoupling
4	IF2	IF input 2
5	TUD	Delayed tuner AGC current out
6	AGCT	Tuner AGC take over
7	AGCS	AGC storage capacitor
8	GND	Ground
9	INPS	Input select
10	OUTQ	Baseband Q output
11	OUTI	Baseband I output
12	VCCPA	Supply voltage power amplifier
13	ELS	External output level set
14	INPO	Oscillator input
15	FEDO	Oscillator feedback
16	GRDO	Oscillator ground
17	PRSO	Prescaler output
18	PRSO	Prescaler output
19	GND	Ground
20	VCC	Supply voltage

Figure 2. Pinning

Absolute Maximum Ratings

All voltages are referred to GND (Pin 13)

Parameters		Symbol	Min.	Typ.	Max.	Unit
Supply voltage	Pins 1, 12 and 20	VCCRF VCCPA VCC	-0.3		6.0	V
Signal inputs external DC current	Pins 2 and 4	IF1, IF2	-0.2		0.2	mA
Signal outputs external DC voltage	Pins 10 and 11	OUT	-0.3		V _{CC}	V
Signal outputs DC current	Pins 10 and 11	OUT			8.0	mA
Maximum AGC voltage	Pin 5	TUD	-0.3		VCCRF	V
Tuner AGC current	Pin 5	TUD	0		2.0	mA
Maximum prescaler output current	Pins 17 and 18	PRSO			10	mA
Junction temperature		T _j	-40		150	°C
Storage temperature		T _{stg}	-40		125	°C

Operation Range

All voltages are referred to GND (Pin 13)

Parameters		Symbol	Min.	Typ.	Max.	Unit
Supply voltage	Pins 1, 12 and 20	VCCRF VCCPA VCC	4.5		5.5	V
Ambient temperature		T _{amb}	0		70	°C
Input frequency	Pins 13 and 14	IF _{in}	390		520	MHz

Thermal Resistance

Parameters		Symbol	Min.	Typ.	Max.	Unit
Junction ambient		R _{thJA}				K/W

Electrical Characteristics

Test conditions: $V_{SRF} = +5\text{ V}$, $T_{amb} = +25^\circ\text{C}$, unless otherwise specified

Parameters	Test Conditions / Pins	Symbol	Min.	Typ.	Max.	Unit
Supply current	Pins 1, 12 and 20	I_S		40		mA
IF input Pins 2 and 4						
Impedance		Z_0		50		Ω
Operation range		f_{IF}	390	480	520	MHz
Sensitivity	$f_{IF} = 480\text{ MHz}$	f_{IF}		57		$\text{dB}\mu\text{V}$
Second order intercept	Note 1	IP_2	76			$\text{dB}\mu\text{V}$
Third order intercept	Note 1	IP_3	80			$\text{dB}\mu\text{V}$
	Note 2	IP_3	110			$\text{dB}\mu\text{V}$
Noise figure SSB		NF		10		dB
AGC range				-35		dB
Oscillator phase noise	10 kHz offset		-80			dBc/Hz
Prescaler output amplitude	Pins 17 and 18 Note 4		1.0			V_{PP}
Baseband outputs						
Amplitude	Pins 10 and 11 Note 5		0.9	1.0	1.1	V_{PP}
Maximum amplitude	Pins 10 and 11		1.5			V_{PP}
External level adjust	Pin 12 Note 3		0.6		1.0	V_{PP}
Bandwidth	$\pm 0.25\text{ dB}$, Pins 10 and 11 Note 4	f_{out}	20			MHz
	$\pm 1.0\text{ dB}$, note 4		30			MHz
Relative phase error	Output I vs. Q, note 3 Pins 10 and 11				3	Degree
Relative amplitude error	Output I vs. Q, note 3				0.5	dB
Input isolation	Input 1 vs. input 2 Pins 2 and 4		-30			dB
Spurious oscillator at outputs (LC tank, 480 MHz, internal leveled, note 6, Pins 10 and 11)						
Spurious at f_{osc}	$V_{CC} = 4.5\text{ to }5.5\text{ V}$			<-40		dBc
Spurious at $2 \times f_{osc}$				<-40		dBc
Oscillator frequency drift		Δf_{osc}		200		

- | | |
|---|---|
| 1) AGC set for maximum gain | 4) Load impedance $220\ \Omega$ in series to $2,2\ \text{k}\Omega$ $47\ \text{pF}$ |
| 2) AGC set for minimum gain | 5) Internal AGC function activated, see application circuit figure 1 |
| 3) External AGC setting, see application circuit figure 2 | 6) see test circuit |

Functional Description

The input signal is via two single ended constant gain amplifiers with selectable inputs connected to a gain controlled amplifier. The differential output signal remains of constant amplitude to provide – behind splitting up – optimised dynamic operation points for a pair of identical mixers. The mixer stages are driven by two orthogonal oscillator signals, to generate the I- and Q-components.

The oscillator operates at IF-frequency. Therefore control by an on the shelf SAW resonator is possible. Using the internal 1/32 frequency divider circuit a VCO carrier recovery loop can be closed via the base band decoding system.

Excellent accuracy of 0°/90° phase shifting between the demodulator switching carriers is provided by a TEMIC patented phase correction circuit, which operates in a wide input frequency range.

Two matched amplifiers with second order lowpass characteristic to suppress oscillator spurious ensure small gain and phase errors between both channels and mini-

mize tilt. The output stages may drive complex loads up to 220 Ω in series to 2.2 kΩ and 50 pF in a frequency range up to 40 MHz.

To avoid fast system lock in time and driving the A/D converters with defined output levels, in one channel the output signal will be peak-level detected and in an internally loop level controlled. So the output signal amplitudes are independent of frequency and characteristic of the QPSK modulation. The output level can be set via an external potentiometer (or at two fixed levels by pin programming) according the actual application. External loop control by a channel decoder generated AGC signal is provided.

The DC-component of the AGC loop affects the IF input level. This signal is internally compared with a adjustable threshold and generates a tuner AGC signal.

Small tolerances based on high DC operation point stability and good spurious signal suppression are performed by an internal reference voltage source.

Basic Application Circuit

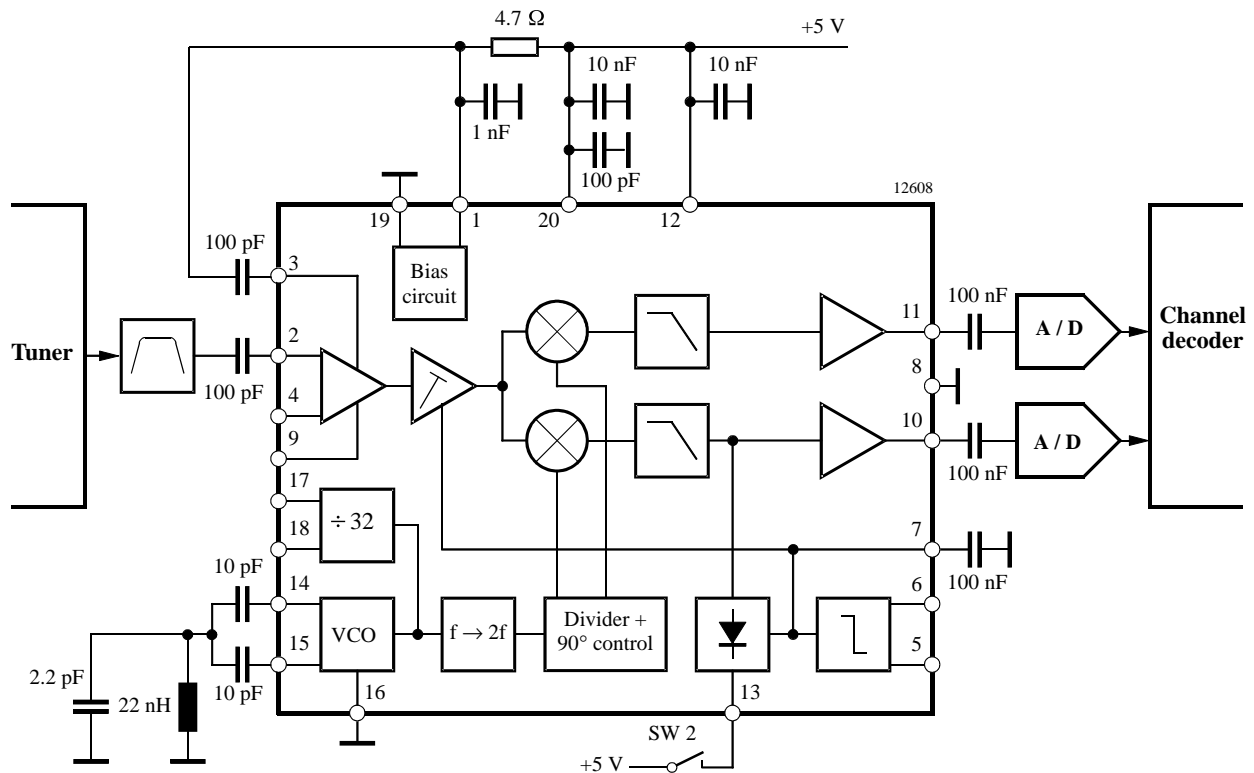

Figure 3. Internal AGC loop, output level optional changeable 0.6 Vpp to 1 Vpp by control voltage at Pin 13, VCO carrier recovery

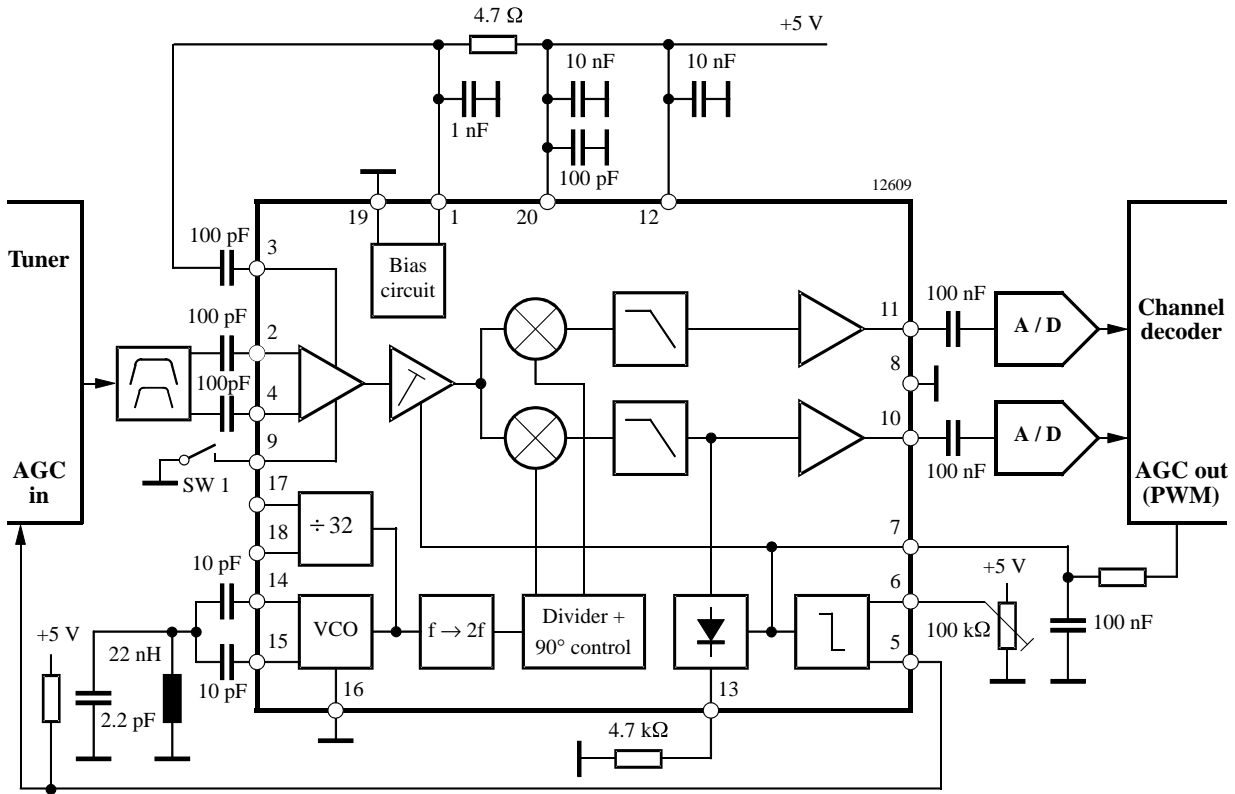
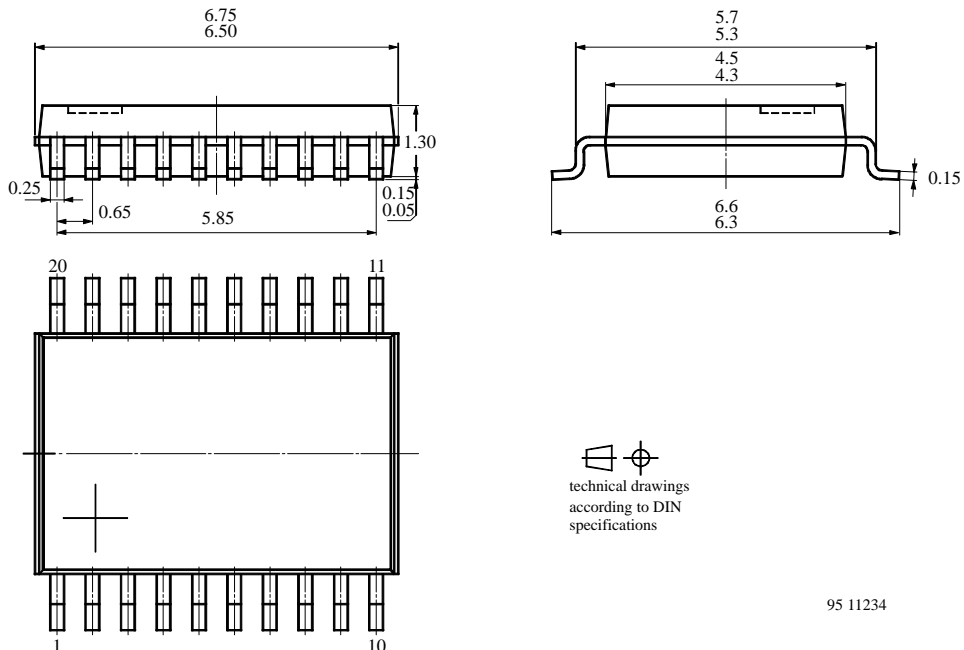

Figure 4. AGC set by channel decoder, fixed VCO frequency SAW resonator carrier recovery, dual bandwidth IF filter, SW1 selects input

Package Information

Package: Super small outline plastic package, 20 pin – SSO20
 Dimensions in mm



95 11234

Ozone Depleting Substances Policy Statement

It is the policy of **TEMIC TELEFUNKEN microelectronic GmbH** to

1. Meet all present and future national and international statutory requirements.
2. Regularly and continuously improve the performance of our products, processes, distribution and operating systems with respect to their impact on the health and safety of our employees and the public, as well as their impact on the environment.

It is particular concern to control or eliminate releases of those substances into the atmosphere which are known as ozone depleting substances (ODSs).

The Montreal Protocol (1987) and its London Amendments (1990) intend to severely restrict the use of ODSs and forbid their use within the next ten years. Various national and international initiatives are pressing for an earlier ban on these substances.

TEMIC TELEFUNKEN microelectronic GmbH semiconductor division has been able to use its policy of continuous improvements to eliminate the use of ODSs listed in the following documents.

1. Annex A, B and list of transitional substances of the Montreal Protocol and the London Amendments respectively
2. Class I and II ozone depleting substances in the Clean Air Act Amendments of 1990 by the Environmental Protection Agency (EPA) in the USA
3. Council Decision 88/540/EEC and 91/690/EEC Annex A, B and C (transitional substances) respectively.

TEMIC can certify that our semiconductors are not manufactured with ozone depleting substances and do not contain such substances.

We reserve the right to make changes to improve technical design and may do so without further notice.

Parameters can vary in different applications. All operating parameters must be validated for each customer application by the customer. Should the buyer use TEMIC products for any unintended or unauthorized application, the buyer shall indemnify TEMIC against all claims, costs, damages, and expenses, arising out of, directly or indirectly, any claim of personal damage, injury or death associated with such unintended or unauthorized use.

TEMIC TELEFUNKEN microelectronic GmbH, P.O.B. 3535, D-74025 Heilbronn, Germany
Telephone: 49 (0)7131 67 2831, Fax number: 49 (0)7131 67 2423