

Phase Control Circuit – Tacho Applications

Description

The integrated circuit U209B3 is designed as a phase control circuit in bipolar technology with an internal frequency-voltage converter. Furthermore, it has an internal open-loop amplifier which means it can be used for motor speed control with tacho feedback.

The U209B3 is a 14 pin shrink version of the U211B2 with reduced features. The designer is able to realize sophisticated as well as economic motor control systems.

Features

- Internal frequency-to-voltage converter
- Externally controlled integrated amplifier
- Automatic soft start with minimized “dead time”
- Voltage and current synchronization
- Retriggering
- Triggering pulse typ. 155 mA
- Internal supply voltage monitoring
- Temperature-compensated reference source
- Current requirement ≤ 3 mA

Package: DIP14, SO16

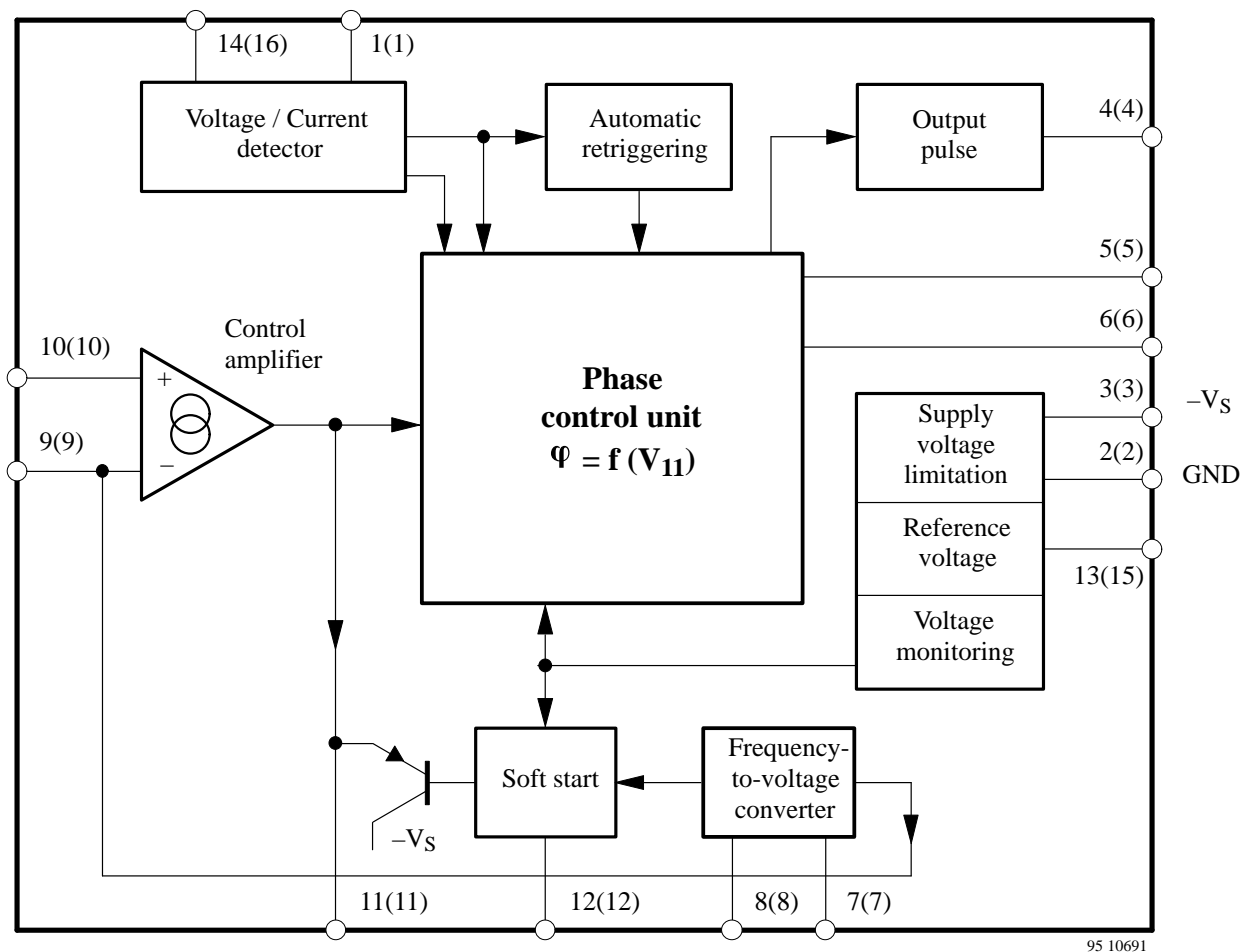

Figure 1. Block diagram (Pins in brackets refer to SO16)

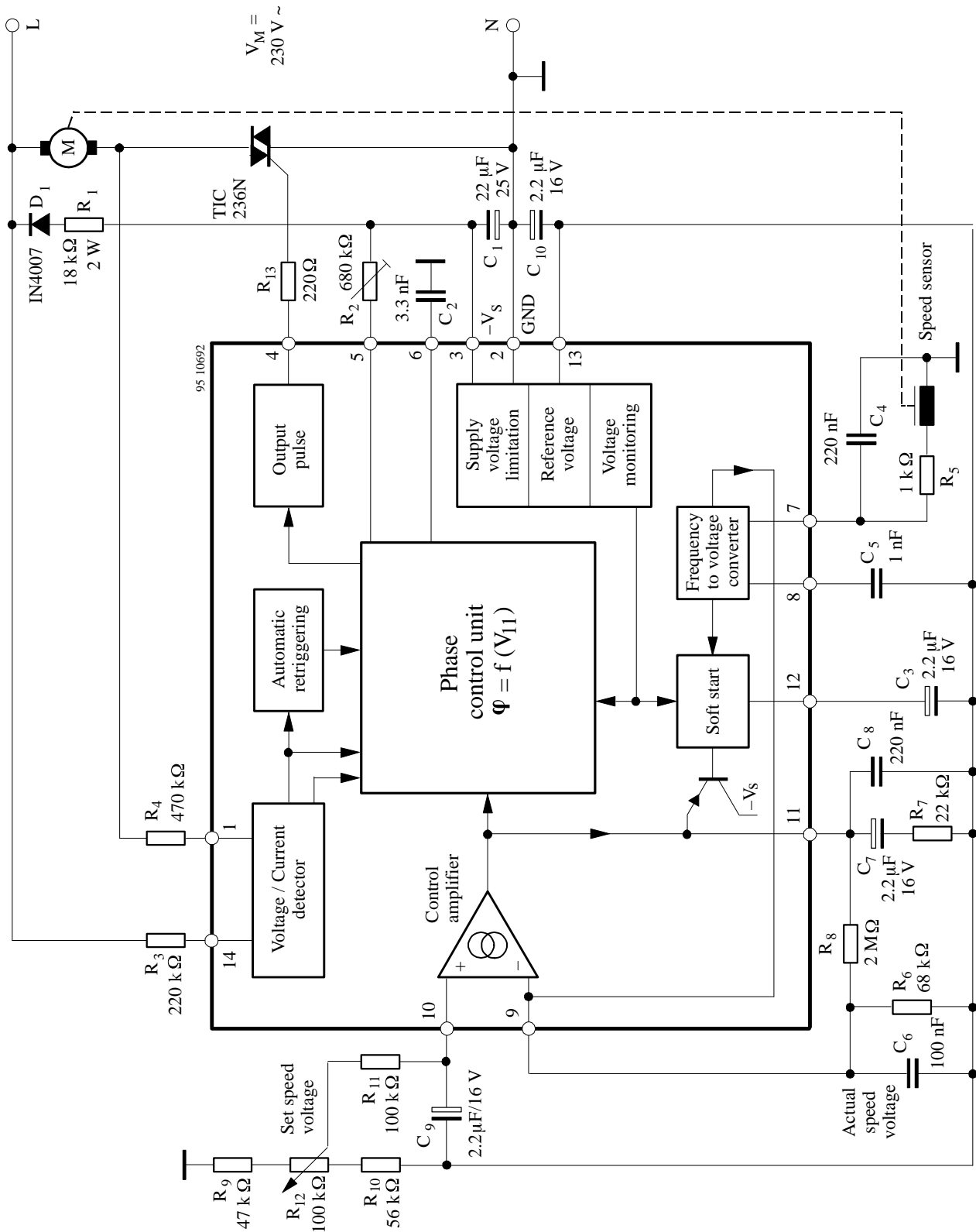

Figure 2. Block diagram with typical circuitry for speed regulation

Description

Mains Supply

The U209B is designed with voltage limiting and can therefore be supplied directly from the mains. The supply voltage between Pin 2 (+ pol/⊥) and Pin 3 builds up across D₁ and R₁ and is smoothed by C₁. The value of the series resistance can be approximated using (figure 2):

$$R_1 = \frac{V_M - V_S}{2 I_S}$$

Further information regarding the design of the mains supply can be found in the data sheets in the appendix. The reference voltage source on Pin 13 of typ. -8.9 V is derived from the supply voltage and represents the reference level of the control unit.

Operation using an externally stabilised DC voltage is not recommended.

If the supply cannot be taken directly from the mains because the power dissipation in R₁ would be too large, then the circuit shown in the following figure 3 should be employed.

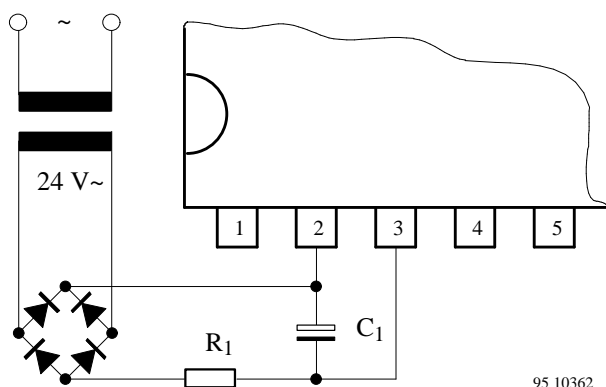

Figure 3. Supply voltage for high current requirements

Phase Control

The function of the phase control is largely identical to that of the well known integrated circuit TEA1007. The phase angle of the trigger pulse is derived by comparing the ramp voltage. This is mains synchronized by the voltage detector with the set value on the control input Pin 4. The slope of the ramp is determined by C₂ and its charging current. The charging current can be varied using R₂ on Pin 5. The maximum phase angle α_{max} can also be adjusted using R₂.

When the potential on Pin 6 reaches the nominal value predetermined at Pin 11, a trigger pulse is generated whose width t_p is determined by the value of C₂ (the value of C₂ and hence the pulse width can be evaluated by assuming 8 μ s/nF).

The current sensor on Pin 1 ensures that no pulse is generated (for operation with inductive loads) in a new half cycle as long as the current from the previous half cycle is still flowing in the opposite direction to the supply voltage at that instant. This makes sure that "Gaps" in the load current are prevented.

The control signal on Pin 11 can be in the range 0 V to -7 V (reference point Pin 2).

If $V_{11} = -7$ V then the phase angle is at maximum = α_{max} , i.e., the current flow angle is a minimum. The minimum phase angle α_{min} is when $V_{11} = V_{pin2}$.

Voltage Monitoring

As the voltage is built up, uncontrolled output pulses are avoided by internal voltage surveillance. At the same time, all of the latches in the circuit (phase control, soft start) are reset and the soft-start capacitor is short circuited. Used with a switching hysteresis of 300 mV, this system guarantees defined start-up behaviour each time the supply voltage is switched on or after short interruptions of the mains supply.

Soft-Start

As soon as the supply voltage builds up (t_1), the integrated soft-start is initiated. The figure below shows the behaviour of the voltage across the soft-start capacitor and is identical with the voltage on the phase control input on Pin 11. This behaviour guarantees a gentle start-up for the motor and automatically ensures the optimum run-up time.

C₃ is first charged up to the starting voltage V_0 with typically 30 μ A current (t_2). By then reducing the charging current to approx. 4 μ A, the slope of the charging function is substantially reduced so that the rotational speed of the motor only slowly increases. The charging current then increases as the voltage across C₃ increases giving a progressively rising charging function which accelerates the motor with increasing rotational speed. The charging function determines the acceleration up to the set-point. The charging current can have a maximum value of 50 μ A.

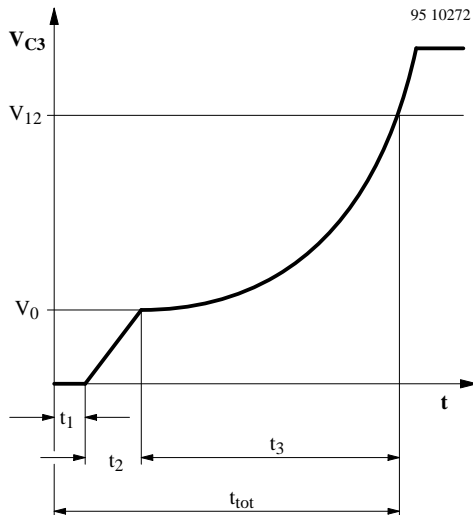

Figure 4. Soft-start

- t_1 = build-up of supply voltage
- t_2 = charging of C_3 to starting voltage
- $t_1 + t_2$ = dead time
- t_3 = run-up time
- t_{tot} = total start-up time to required speed

Frequency to Voltage Converter

The internal frequency to voltage converter (f/V-converter) generates a DC signal on Pin 9 which is proportional to the rotational speed using an AC signal from a tachogenerator or a light beam whose frequency is in turn dependent on the rotational speed. The high impedance input with a switch-on threshold of typ. – 100 mV gives very reliable operation even when relatively simple tachogenerators are employed. The tachofrequency is given by:

$$f = \frac{n}{60} \text{ p[Hz]}$$

n = revolutions per minute

p = number of pulses per revolution

The converter is based on the charge pumping principle. With each negative half wave of the input signal, a quantity of charge determined by C_5 is internally amplified and then integrated by C_6 at the converter output on Pin 9. The conversion constant is determined by C_5 , its charging voltage of V_{ch} , R_6 (Pin 9) and the internally adjusted charge amplification G_i .

$$k = G_i \times C_5 \times R_6 \times V_{ch}$$

The analog output voltage is given by

$$V_o = k \times f.$$

whereas: $V_{ch} = 6.7 \text{ V}$

$$G_i = 8.3$$

The values of C_5 and C_6 must be such that for the highest possible input frequency, the maximum output voltage V_o does not exceed 6 V. The R_i on Pin 8 is approx. 6 k Ω while C_5 is charging up. To obtain good linearity of the f/V converter the time constant resulting from R_i and C_5 should be considerably less (1/5) than the time span of the negative half cycle for the highest possible input frequency. The amount of remaining ripple on the output voltage on Pin 9 is dependent on C_5 , C_6 and the internal charge amplification.

$$\Delta V_o = \frac{G_i \times V_{ch} \times C_5}{C_6}$$

The ripple ΔV_o can be reduced by using larger values of C_6 , however, the maximum conversion speed will then also be reduced.

The value of this capacitor should be chosen to fit the particular control loop where it is going to be used.

Control Amplifier

The integrated control amplifier with differential input compares the set value (Pin 10) with the instantaneous value on Pin 9 and generates a regulating voltage on the output Pin 11 (together with external circuitry on Pin 12) which always tries to hold the real voltage at the value of the set voltages. The amplifier has a transmittance of typically 110 $\mu\text{A/V}$ and a bipolar current source output on Pin 11 which operates with typically $\pm 100 \mu\text{A}$. The amplification and frequency response are determined by R_7 , C_7 , C_8 and R_8 (can be left out). For operation as a power divider, C_4 , C_5 , R_6 , C_6 , R_7 , C_7 , C_8 and R_8 can be left out. Pin 9 should be connected with Pin 11 and Pin 7 with Pin 2. The phase angle of the triggering pulse can be adjusted using the voltage on Pin 10. An internal limiting circuit prevents the voltage on Pin 11 from becoming more negative than $V_{I3} + 1 \text{ V}$.

Pulse Output Stage

The pulse output stage is short circuit protected and can typically deliver currents of 125 mA. For the design of smaller triggering currents, the function $I_{GT} = f(R_{GT})$ has been given in the data sheets in the appendix.

Automatic Retriggering

The automatic retriggering prevents half cycles without current flow, even if the triacs are turned off earlier e.g., due to not exactly centered collector (brush lifter) or in the event of unsuccessful triggering. If necessary, another triggering pulse is generated after a time lapse of $t_{pp} = 4.5 t_p$ and this is repeated until either the triac fires or the half cycle finishes.

General Hints and Explanation of Terms

To ensure safe and trouble-free operation, the following points should be taken into consideration when circuits are being constructed or in the design of printed circuit boards.

- The connecting lines from C₂ to Pin 6 and Pin 2 should be as short as possible, and the connection to Pin 2 should not carry any additional high current such as the load current. When selecting C₂, a low temperature coefficient is desirable.
- The common (earth) connections of the set-point generator, the tacho-generator and the final interference suppression capacitor C₄ of the f/V converter should not carry load current.
- The tacho generator should be mounted without influence by strong stray fields from the motor.

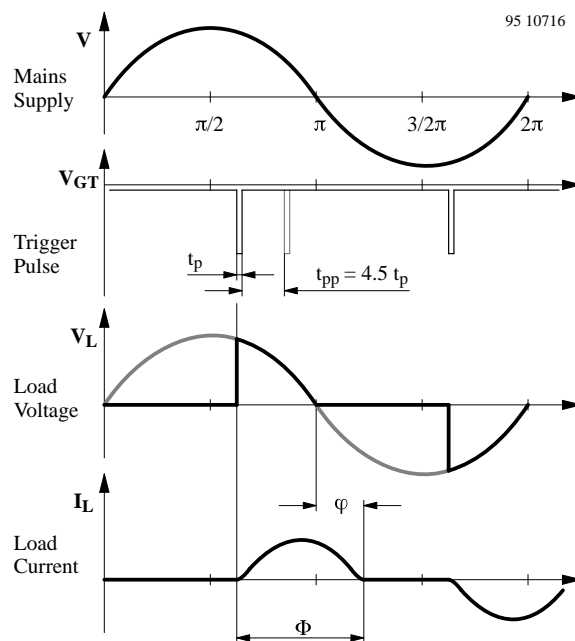

Figure 5. Explanation of terms in phase relationship

Design Calculations for Mains Supply

The following equations can be used for the evaluation of the series resistor R₁ for worst case conditions:

$$R_{1\max} = 0.85 \frac{V_{M\min} - V_{S\max}}{2 I_{\text{tot}}} \quad R_{1\min} = 0.85 \frac{V_M - V_{S\min}}{2 I_{S\max}}$$

$$P_{(R1\max)} = \frac{(V_{M\max} - V_{S\min})^2}{2 R_1}$$

where:

V_M = Mains voltage 230 V

V_S = Supply voltage on Pin 3

I_{tot} = Total DC current requirement of the circuit

= I_S + I_p + I_x

I_{Smax} = Current requirement of the IC in mA

I_p = Average current requirement of the triggering pulse

I_x = Current requirement of other peripheral components

R₁ can be easily evaluated from figures 15 to 17

Absolute Maximum Ratings

Reference point Pin 2, unless otherwise specified

Parameters	Symbol	Value	Unit	
Current requirement $t \leq 10 \mu\text{s}$	Pin 3 $-I_S$ $-i_S$	30 100	mA	
Synchronization current $t < 10 \mu\text{s}$ $t < 10 \mu\text{s}$	Pin 1 Pin 14 Pin 1 Pin 14	I_{syncI} I_{syncV} $\pm i_i$ $\pm i_v$	5 5 35 35	mA
f/V converter: Input current $t < 10 \mu\text{s}$	Pin 7 I_{eff} $\pm i_i$	3 13	mA	
Phase control:	Pin 11			
Input voltage Input current	$-V_I$ $\pm I_I$	0 to 7 500	V μA	
Soft-start: Input voltage	Pin 12 $-V_I$	$ V_{13} $ to 0	V	
Pulse output: Reverse voltage	Pin 4 V_R	V_S to 5	V	
Amplifier				
Input voltage Pin 8 open	Pin 10 Pin 9 $-V_I$	$ V_S $ $ V_{13} $ to 0	V	
Reference voltage source				
Output current	Pin 13 I_o	7.5	mA	
Power dissipation	$T_{\text{amb}} = 45^\circ\text{C}$ $T_{\text{amb}} = 80^\circ\text{C}$ P_{tot}	570 320	mW	
Storage temperature range	T_{stg}	-40 to +125	°C	
Junction temperature	T_j	125		
Ambient temperature range	T_{amb}	-10 to +100		

Thermal Resistance

Parameters	Symbol	Maximum	Unit
Junction ambient DIP14 SO16: on p.c. board SO16: on ceramic substrate	R_{thJA}	140 180 100	K/W

Electrical Characteristics

$-V_S = 13.0 \text{ V}$, $T_{\text{amb}} = 25^\circ\text{C}$, reference point Pin 2, unless otherwise specified

Parameters	Test Conditions / Pin	Symbol	Min	Typ	Max	Unit
Supply voltage for mains operations	Pin 3	$-V_S$	13.0		V_{Limit}	V
Supply voltage limitation	$-I_S = 3 \text{ mA}$ $-I_S = 30 \text{ mA}$ Pin 3	$-V_S$	14.6 14.7		16.6 16.8	V
DC supply current	$-V_S = 13.0 \text{ V}$ Pin 3	$-I_S$	1.1	2.5	3.0	mA
Reference voltage source	$-I_L = 10 \mu\text{A}$ $-I_L = 5 \text{ mA}$ Pin 13	V_{Ref}	8.6 8.3	8.9	9.2 9.1	V
Temperature coefficient	Pin 13	$TC_{V_{\text{Ref}}}$			0.5	mV/K

Parameters	Test Conditions / Pin	Symbol	Min	Typ	Max	Unit
Voltage monitoring Pin 3						
Turn-on threshold		$-V_{TON}$		11.2	13	V
Turn-off threshold		$-V_{TOFF}$	9.9	10.9		V
Phase control currents						
Current synchronization	Pin 1	$\pm I_{syncI}$	0.35		2.0	mA
Voltage synchronization	Pin 14	$\pm I_{syncV}$	0.35		2.0	mA
Voltage limitation	$\pm I_L = 5 \text{ mA}$ Pin 1, 14	$\pm V_1$	1.4	1.6	1.8	V
Reference ramp, figure 6						
Charge current	$I_6 = f(R_5)$, $R_5 = 1 \text{ K} \dots 820 \text{ k}\Omega$ Pin 6	I_6	1		20	μA
R_ϕ – reference voltage	$\alpha \geq 180^\circ$ Pin 5, 3	$V_{\phi Ref}$	1.06	1.13	1.18	V
Temperature coefficient	Pin 5	$TC_{\phi Ref}$		0.5		mV/K
Output pulse						
Output pulse current	$R_V = 0, V_{GT} = 1.2 \text{ V}$ Pin 4	I_O	100	155	190	mA
Reverse current	Pin 4	I_{OR}		0.01	3.0	μA
Output pulse width	Pin 5, 2	t_p		8		$\mu\text{s/nF}$
Automatic retriggering						
Repetition rate	Pin 4	t_{pp}	3	4.5	6	t_p
Amplifier						
Common mode voltage range	Pin 9, 10	V_{ICR}	$(V_{13}-1V)$		(V_2-1V)	V
Input bias current	Pin 10	I_{IB}		0.01	1	mA
Input offset voltage	Pin 9, 10	V_{IO}		10		mV
Output current	Pin 11	$-I_O$ $+I_O$	75 88	110 120	145 165	μA
Short circuit forward transmittance	$I_{11} = f(V_{9/10})$ Pin 11	Y_f		1000		$\mu\text{A/V}$
Frequency to voltage converter						
Input bias current	Pin 7	I_{IB}		0.6	2	μA
Input voltage limitation	$\pm I_1 = 1 \text{ mA}$ Pin 7	$+V_1$ $-V_1$	660 7.25		750 8.05	mV V
Turn-on threshold	Pin 7	$-V_{TON}$		100	150	mV
Turn-off threshold	Pin 7	$-V_{TOFF}$	20	50		mV
Discharge current	Figure 2 Pin 8	I_{dis}		0.5		mA
Charge transfer voltage	Pin 8	V_{ch}	6.50	6.70	6.90	V
Charge transfer gain I_9 / I_8	Pin 8/9	G_i	7.5	8.3	9.0	
Conversion factor	$C_8 = 1 \text{ nF}, R_9 = 100 \text{ k}\Omega$	k		5.5		mV/Hz
Operating range f/V output	Ref. point Pin 13 Pin 9	V_O		0 – 6		V
Linearity				± 1		%
Soft start figures 7 to 11 Pin 12						
f/v-converter non active						
Starting current	$V_{12} = V_{13}, V_7 = V_2$	I_O	20	30	50	μA
Final current	$V_{12} = -0.5 \text{ V}$	I_O	50	85	130	μA
f/v-converter active						
Starting current	$V_{12} = V_{13}$	I_O	2	4	6	μA
Final current	$V_{12} = -0.5 \text{ V}$	I_O	30	55	80	μA
Discharge current	Restart pulse	$-I_O$	0.5	3	10	mA

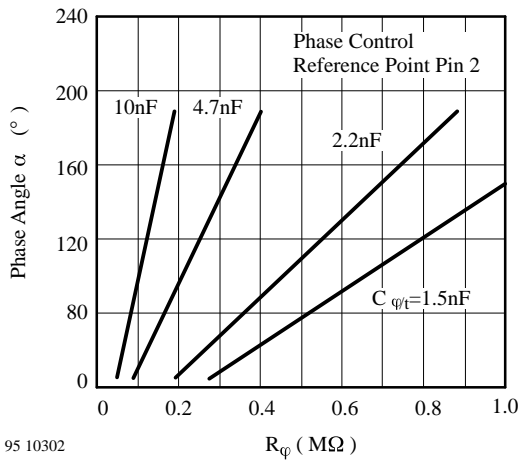

Figure 6.

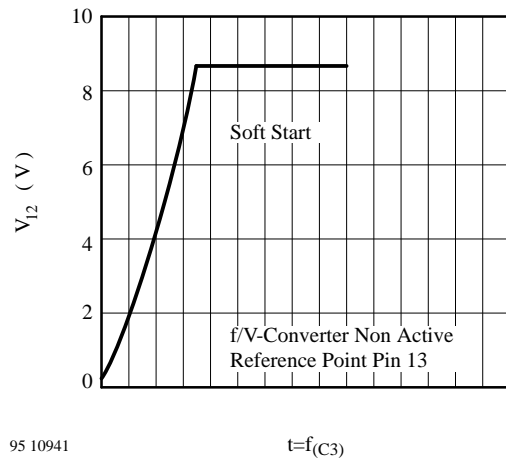

Figure 9.

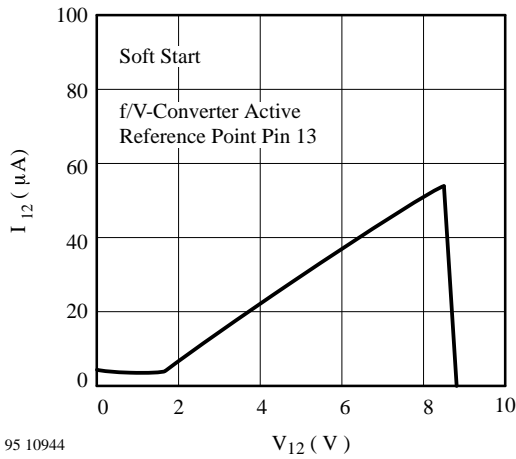

Figure 7.

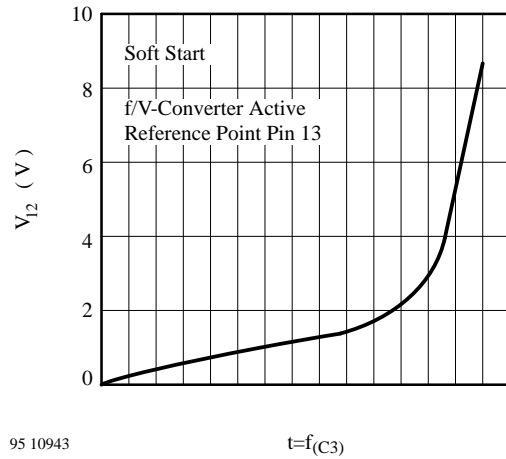

Figure 10.

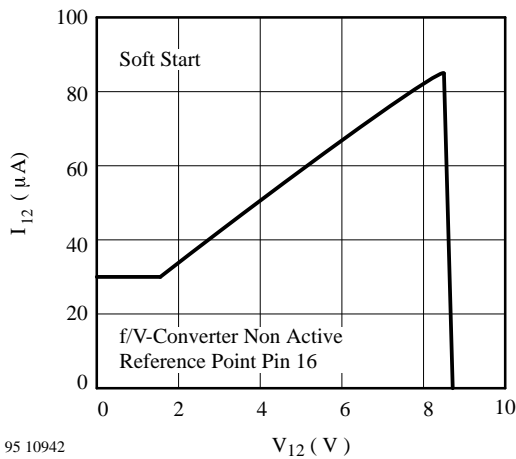

Figure 8.

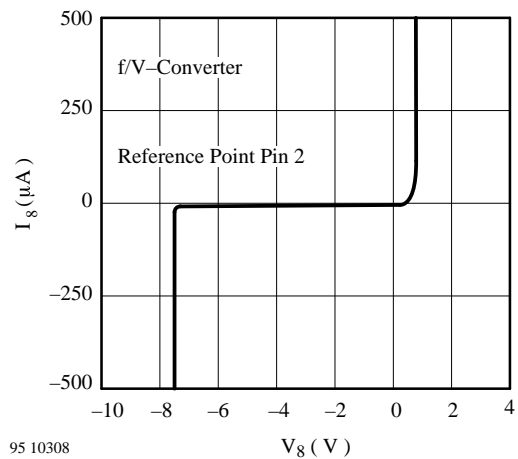

Figure 11.

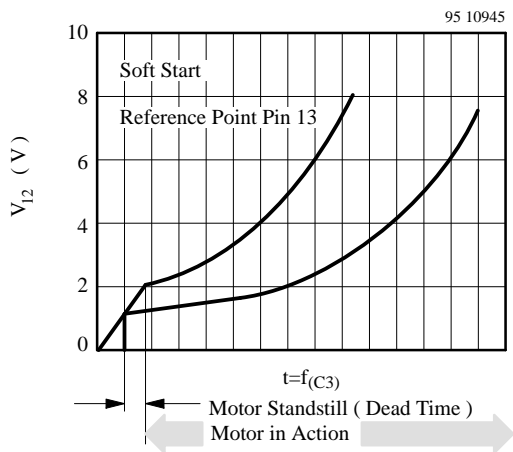

Figure 12.

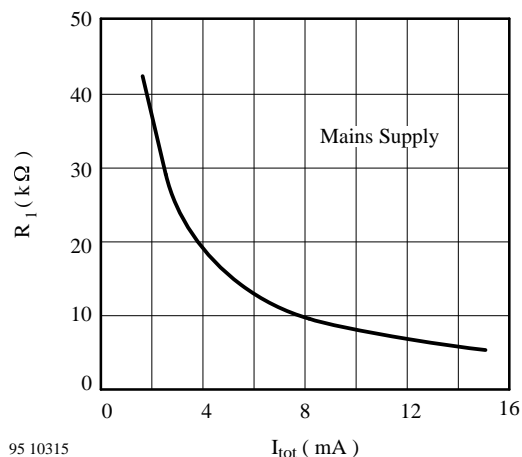

Figure 15.

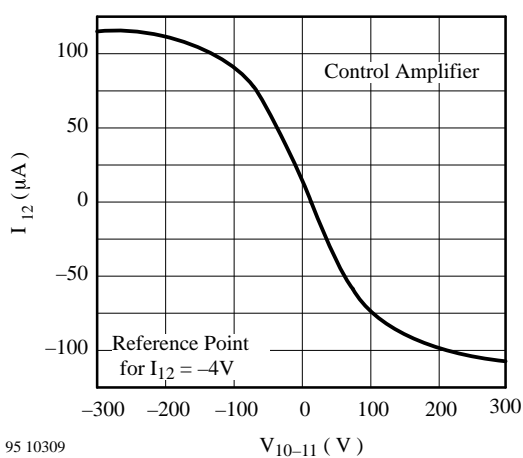

Figure 13.

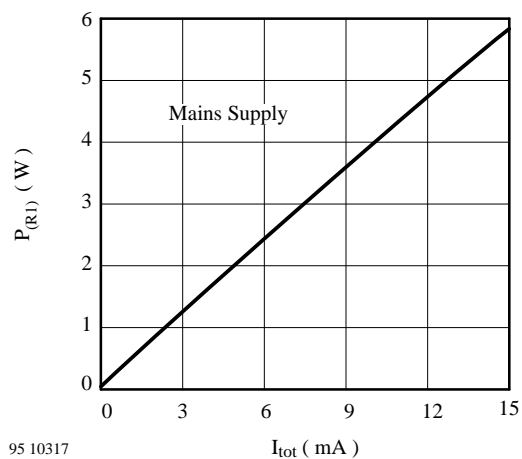

Figure 16.

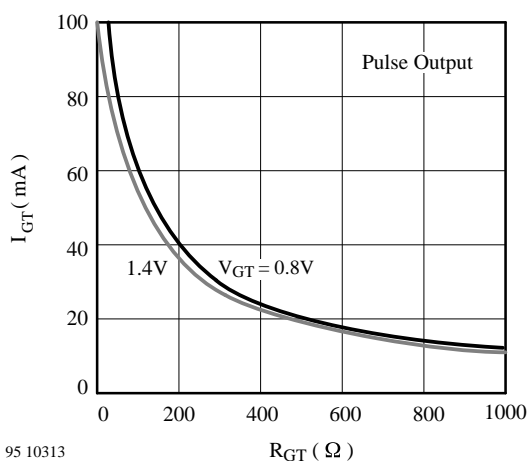

Figure 14.

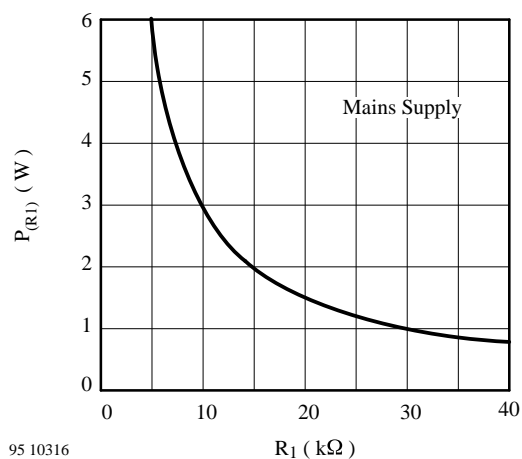
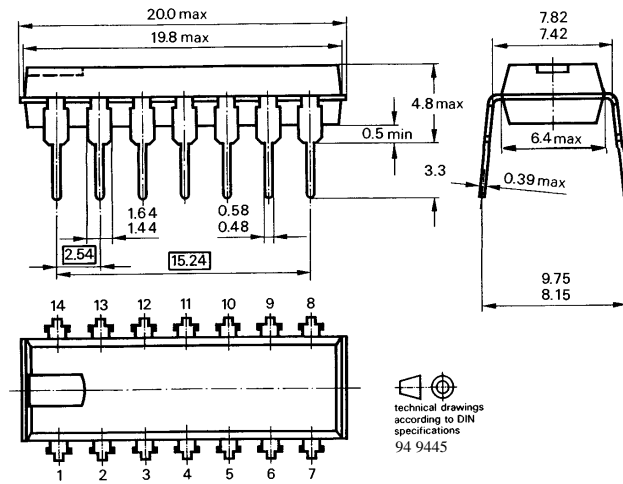

Figure 17.

U209B3/ U209B3-FP

Dimensions in mm

Package: DIP14 – U209B3



Package: SO16 – U209B3-FP

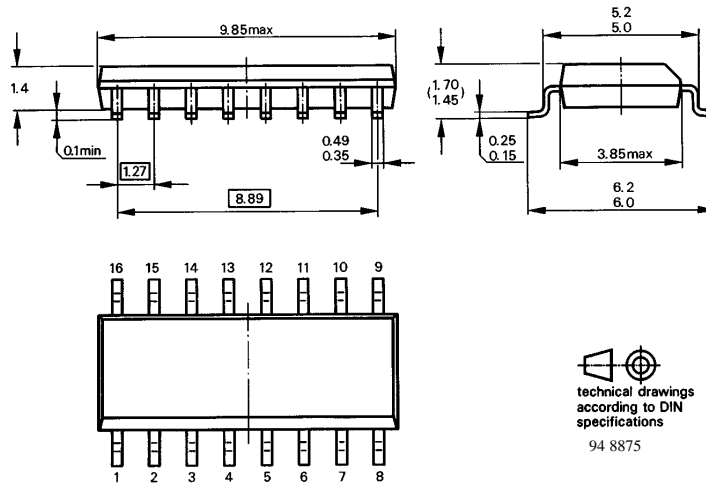

Ozone Depleting Substances Policy Statement

It is the policy of **TEMIC TELEFUNKEN microelectronic GmbH** to

1. Meet all present and future national and international statutory requirements.
2. Regularly and continuously improve the performance of our products, processes, distribution and operating systems with respect to their impact on the health and safety of our employees and the public, as well as their impact on the environment.

It is particular concern to control or eliminate releases of those substances into the atmosphere which are known as ozone depleting substances (ODSs).

The Montreal Protocol (1987) and its London Amendments (1990) intend to severely restrict the use of ODSs and forbid their use within the next ten years. Various national and international initiatives are pressing for an earlier ban on these substances.

TEMIC TELEFUNKEN microelectronic GmbH semiconductor division has been able to use its policy of continuous improvements to eliminate the use of ODSs listed in the following documents.

1. Annex A, B and list of transitional substances of the Montreal Protocol and the London Amendments respectively
2. Class I and II ozone depleting substances in the Clean Air Act Amendments of 1990 by the Environmental Protection Agency (EPA) in the USA
3. Council Decision 88/540/EEC and 91/690/EEC Annex A, B and C (transitional substances) respectively.

TEMIC can certify that our semiconductors are not manufactured with ozone depleting substances and do not contain such substances.

We reserve the right to make changes to improve technical design and may do so without further notice.

Parameters can vary in different applications. All operating parameters must be validated for each customer application by the customer. Should the buyer use TEMIC products for any unintended or unauthorized application, the buyer shall indemnify TEMIC against all claims, costs, damages, and expenses, arising out of, directly or indirectly, any claim of personal damage, injury or death associated with such unintended or unauthorized use.

TEMIC TELEFUNKEN microelectronic GmbH, P.O.B. 3535, D-74025 Heilbronn, Germany
Telephone: 49 (0)7131 67 2831, Fax number: 49 (0)7131 67 2423