

APPLICATION MANUAL

Introduction of IF IC for Communications Equipment TK14571L

CONTENTS

1 . DESCRIPTION	2
2 . FEATURES	2
3 . APPLICATIONS	2
4 . PIN CONFIGURATION/BLOCK DIAGRAM	2
5 . PACKAGE OUTLINE	2
6 . ABSOLUTE MAXIMUM RATINGS	3
7 . ELECTRICAL CHARACTERISTICS	3
8 . TEST CIRCUIT	3
9 . TYPICAL CHARACTERISTICS	4
10 . PIN DESCRIPTION	8
11 . TEST BOARD	8
12 . APPLICATIONS INFORMATION	9
13 . NOTES	10
14 . OFFICES	10



Introduction of IF IC for Communications Equipment TK14571L

1. DESCRIPTION

The TK14571L is a wide band IF IC with a maximum IF frequency band of 15 MHz. It includes an IF limiter amplifier and RSSI. The TK14571L is available in the very small SOT23L-8 package.

2. FEATURES

- Very Small Package: SOT23L-8
- Wide Operating Voltage: 1.8~8.5V
- IF Limiter Amplifier with balanced output

3. APPLICATIONS

- Any Communications Equipment

4. PIN CONFIGURATION / BLOCK DIAGRAM

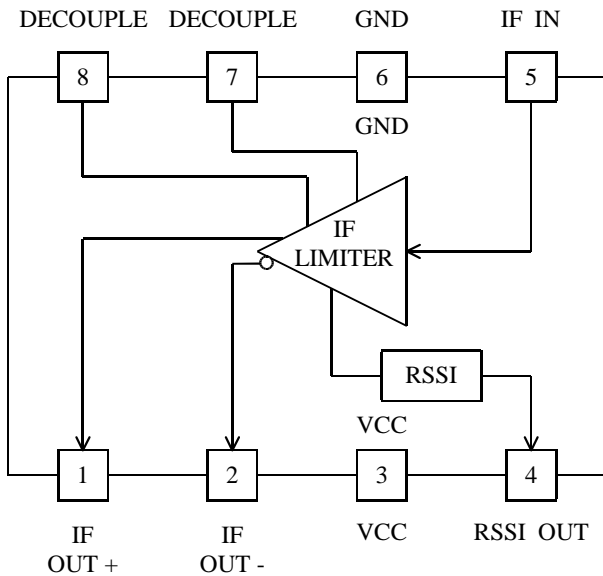

5. PACKAGE OUTLINE

■ SOT23L-8

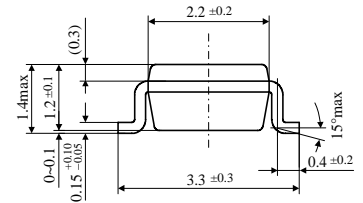
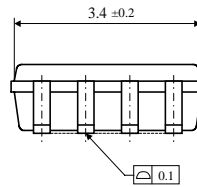
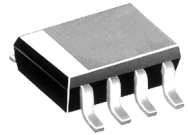
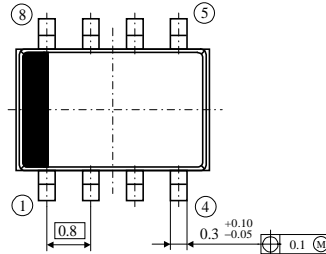

Unit : mm

6. ABSOLUTE MAXIMUM RATINGS

Parameter	Symbol	Rating	Units	Conditions
Supply Voltage	V_{CC}	10.0	V	
Power Dissipation	P_D	150	mW	*
Storage Temperature Range	T_{stg}	-55 ~ +150	°C	
Operating Temperature Range	T_{OP}	-40 ~ 85	°C	
Operating Frequency Range	f_{IF}	0.1 ~ 15	MHz	
Operating Voltage Range	V_{OP}	1.8 ~ 8.5	V	

* P_D must be decreased at rate of 1.2mW/°C for operation at 25°C.

7. ELECTRICAL CHARACTERISTICS

Parameter	Symbol	Value			Units	Conditions
		MIN	TYP	MAX		
Supply Current	I_{CC}		2.5	3.6	mA	No input
IF Limiter						
Output Voltage	V_O	0.30	0.43	0.56	V_{P-P}	
Limiter Gain	G	71	77		dB	
Limiter Input Resistance	R_{in}		330		Ω	DC measurement
RSSI Output Voltage						
RSSI Output Voltage 1	V_{RSSI1}	0.00	0.05	0.30	V	No input
RSSI Output Voltage 2	V_{RSSI2}	0.20	0.40	0.60	V	-60dBm input
RSSI Output Voltage 3	V_{RSSI3}	0.80	1.05	1.30	V	-30dBm input
RSSI Output Voltage 4	V_{RSSI4}	1.20	1.50	1.80	V	0dBm input

8. TEST CIRCUIT

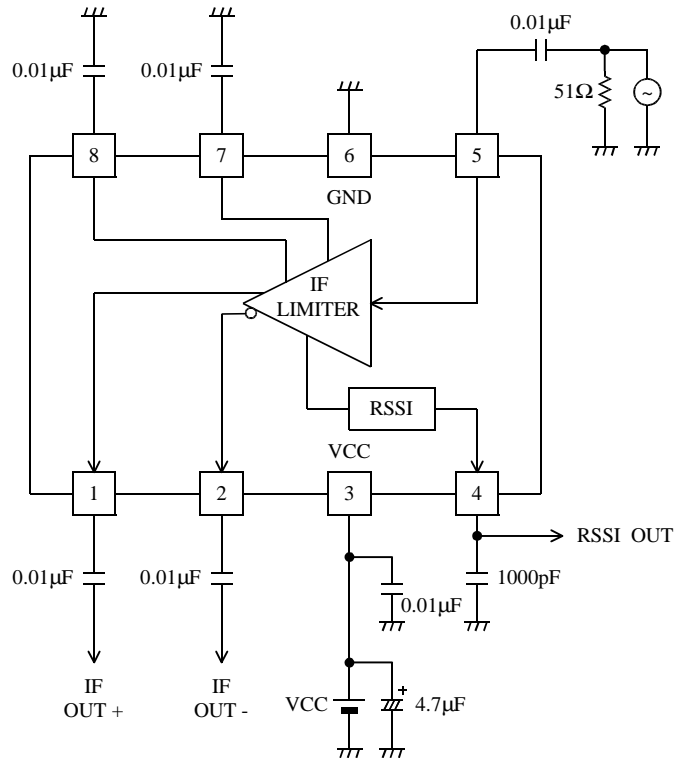

9. TYPICAL CHARACTERISTICS

■ Icc vs. Vcc

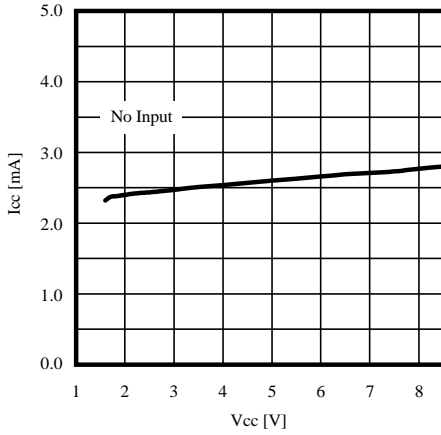

■ RSSI Output Voltage vs. IF Input Level

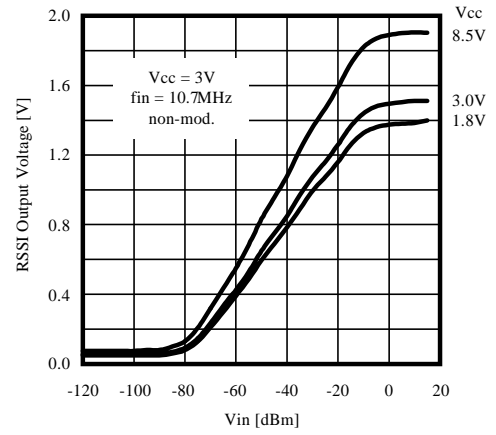

■ Limiter Gain vs. IF Input Frequency

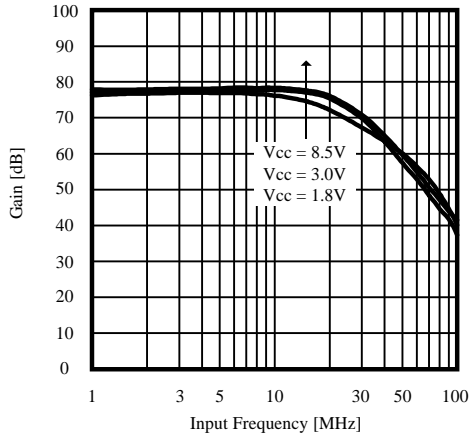

■ Icc vs. Temperature

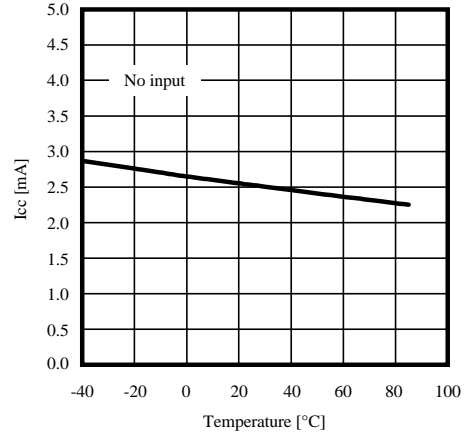

■ RSSI Output Voltage vs. Temperature

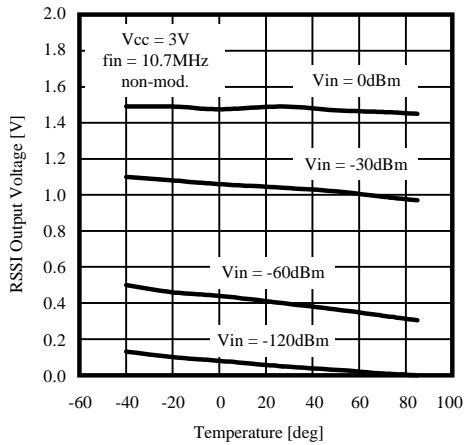

■ RSSI Output Voltage vs. IF Input Level

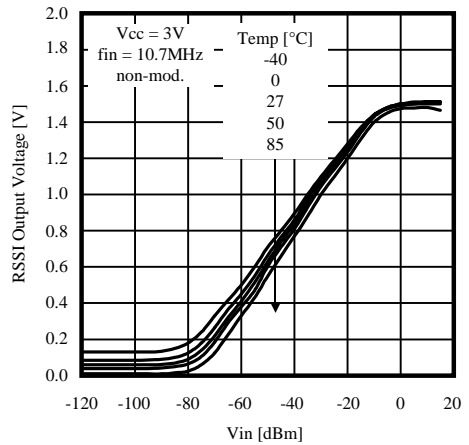

■ RSSI Output Transient Response (IF input ON/ OFF)

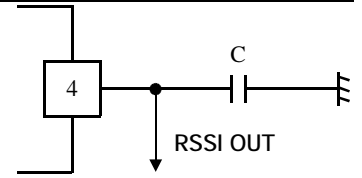

■ C=0.01μF

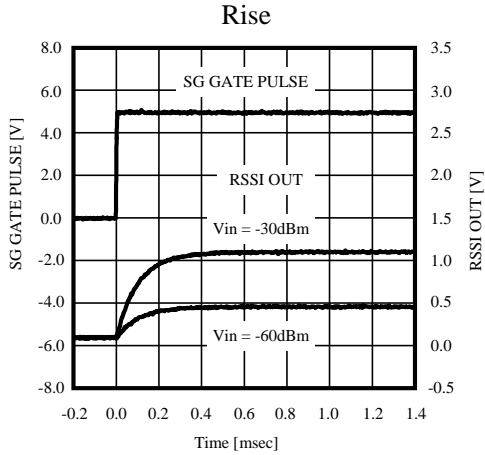

■ C=0.01μF

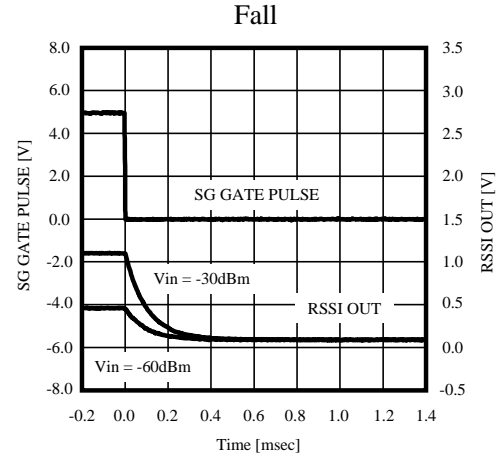

■ C=1000pF

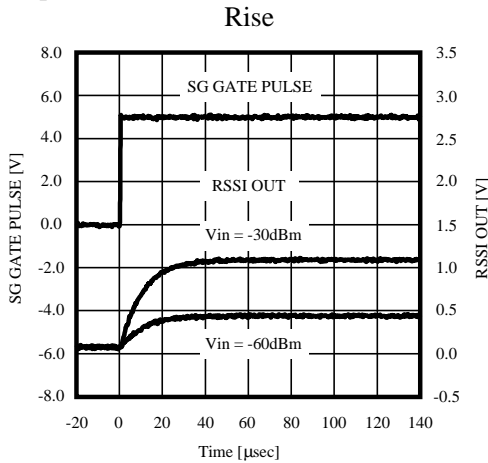

■ C=1000pF

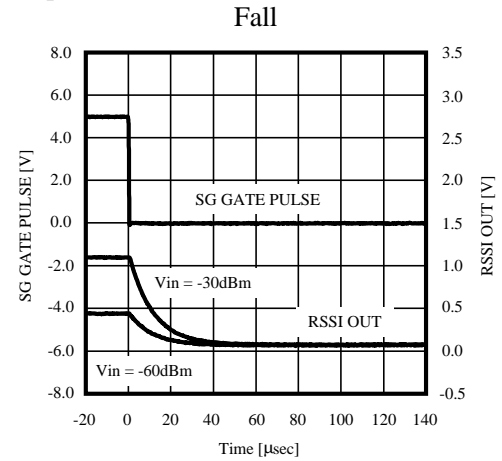

■ C=100pF

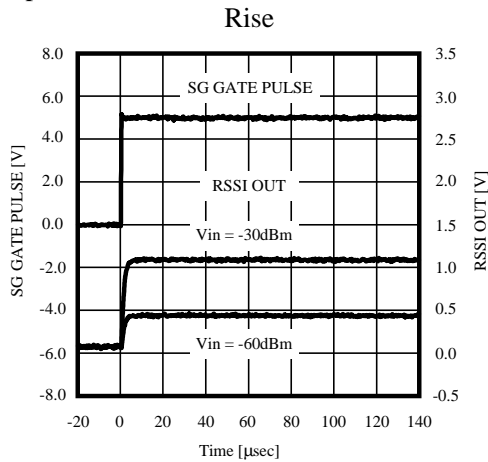

■ C=100pF

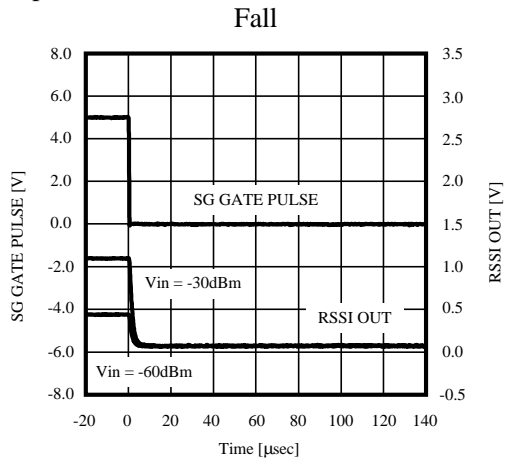

■ RSSI Output Transient Response (Vcc ON/ OFF)

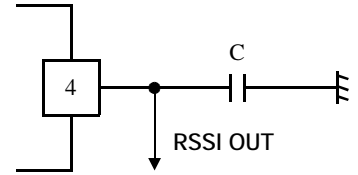

■ C=0.01μF

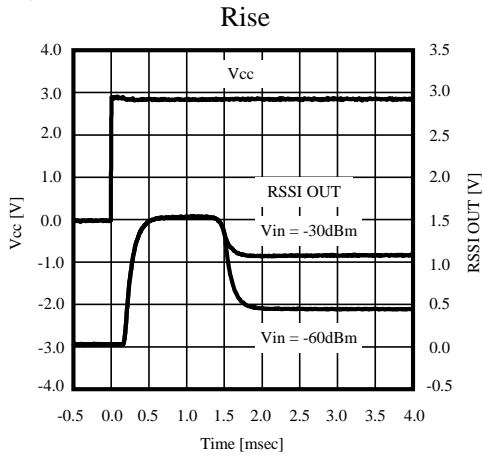

■ C=0.01μF

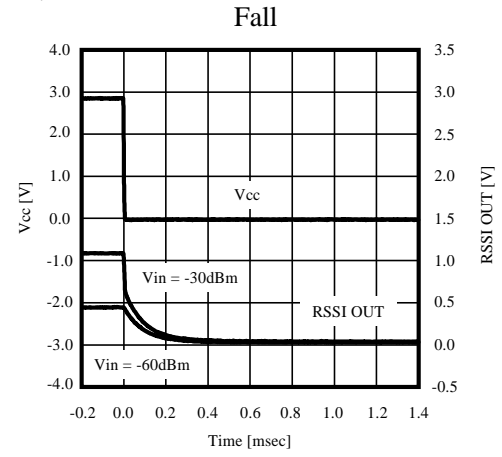

■ C=1000pF

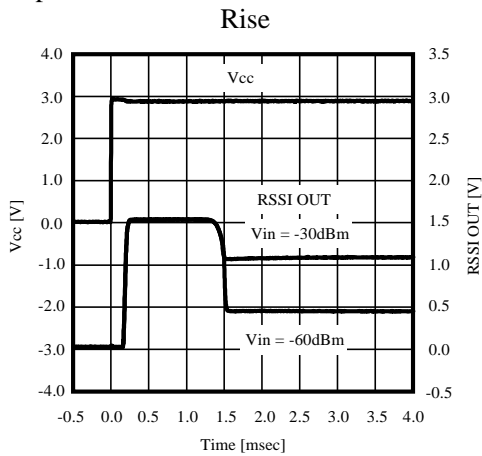

■ C=1000pF

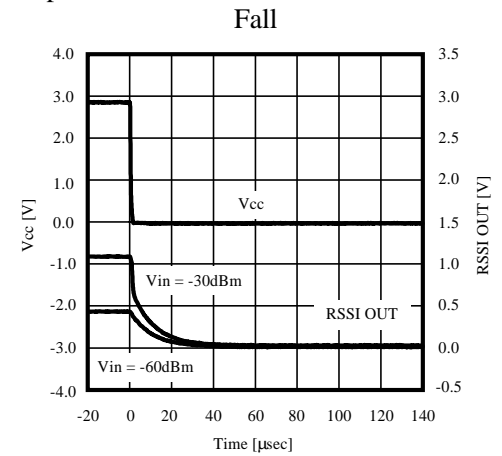

■ C=100pF

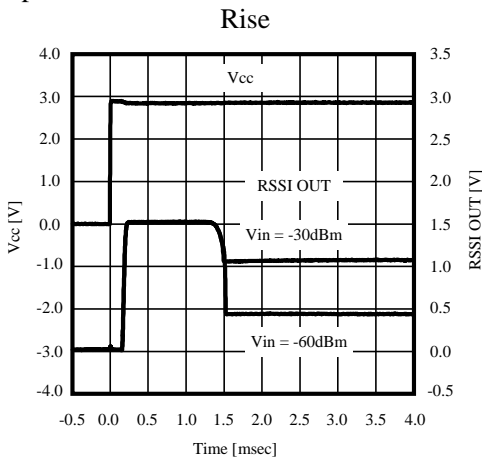

■ C=100pF

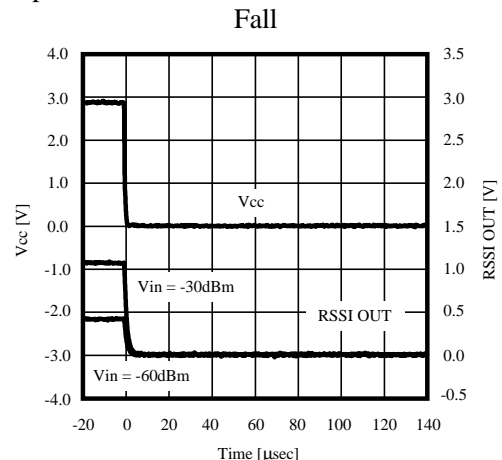

■ AM Demodulation output characteristics by using the RSSI output

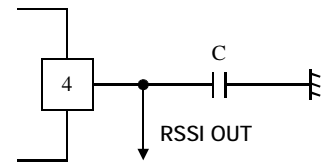

■ Logarithmic Detection
AM Demodulation Voltage vs. Modulating Frequency

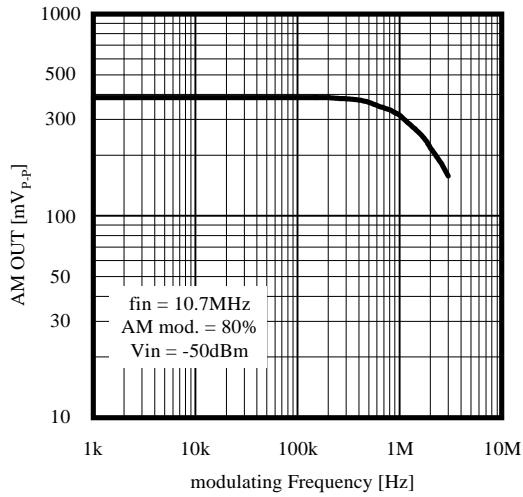

■ Logarithmic Detection
AM Demodulation Voltage vs. IF Input Level

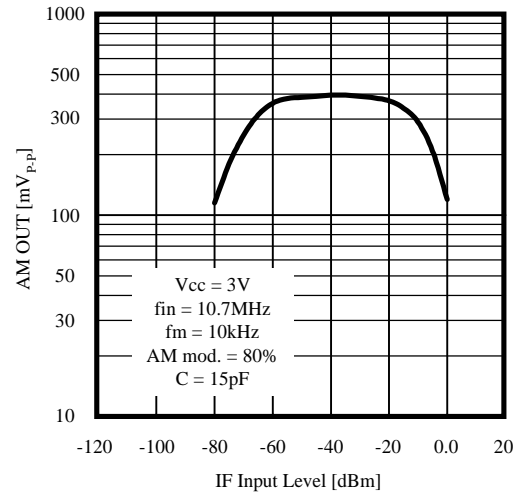

10. PIN DESCRIPTION

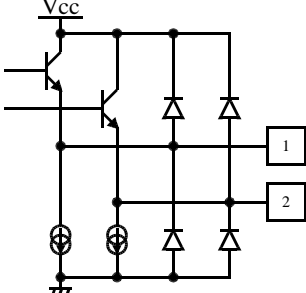
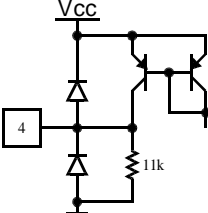
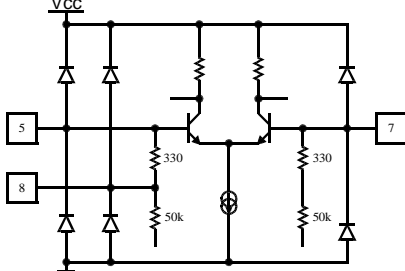
Pin No.	Pin Description	Internal Equivalent Circuit	Description
1 2	IF LIMITER OUT + IF LIMITER OUT -		1, 2: IF Limiter Amplifier Balanced Output Terminals
3	V _{CC}		Power Supply Terminal.
4	RSSI OUTPUT		RSSI Output.
5 7 8	IF INPUT DECOUPLE DECOUPLE		5: IF Limiter Amplifier Input. 7, 8: The terminal to connect the bypass capacitor of the IF limiter amplifier.
6	GND		GND Terminal

11. TEST BOARD

(IC Placement View)

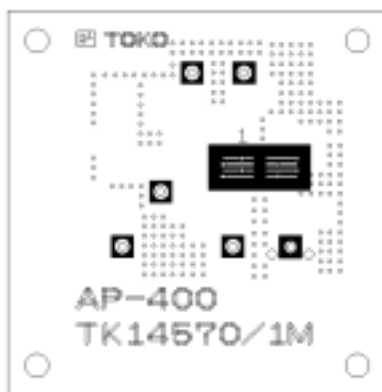

(Component Placement View)

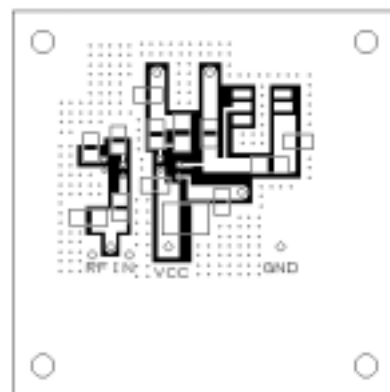

12. APPLICATIONS INFORMATION

12-1. IF Limiter Amplifier

The IF limiter amplifier is composed of five differential amplifier stages. The total gain of the IF limiter is approximately 77 dB at an input frequency of 10.7 MHz. The output signal of the IF limiter amplifier is provided at Pins 1 and 2 through emitter-follower output stages. The IF limiter amplifier output level is 0.43 V_{p,p}. Pins 1 and 2 are the balanced outputs.

The operating current of the IF limiter amplifier emitter-follower output is approximately 420 μA. If the capacitive load is heavy, the negative half cycle of the output waveform may be distorted. In this case, it is possible to improve it by connecting an external resistor between Pin 1, 2 and GND to increase the operating current. The increased operating current by using an external resistor is calculated as follows (see Figure below):

The increased operating current

$$I_e = \frac{V_{CC} - 1.0}{R_e} \text{ (k}\Omega\text{)} \tag{1}$$

Figure 1:

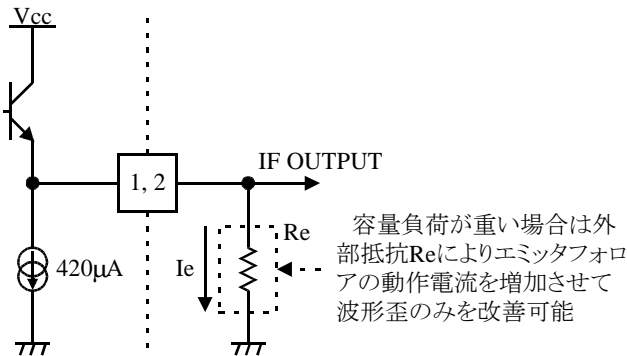

12-2. RSSI

The RSSI output of this product is a voltage output. It converts to voltage by an internal 11 kΩ resistor between Pin 4 and GND. The time constant of the RSSI output is determined by the product of the internal converting resistor and the external parallel capacitor.

When the time constant is longer, the RSSI output is more immune to disturbances or the component of amplitude modulation, but the RSSI output response is lower. Determine the internal resistor and external capacitor with this in mind.

The dynamic range of the RSSI output voltage is approximately 70 dB.

Figure 2: Internal equivalent circuit (RSSI Output)

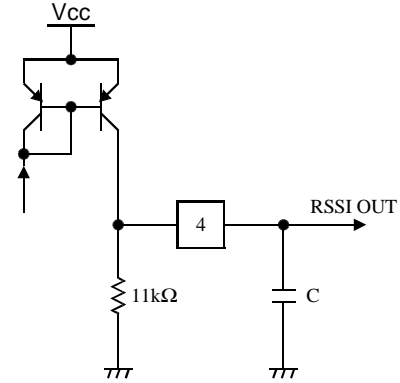

12-3. AM Demodulation by using the RSSI output

Although the distortion of the RSSI output is high because it is a logarithmic detection of the envelope to the IF input, AM can be demodulated simply by using the RSSI output. In this case, the input dynamic range that can demodulate AM is the inside of the linear portion of the RSSI curve characteristics.

This method does not have a feedback loop to control the gain because an AGC amplifier is not necessary (unlike the popularly used AM demodulation method). Therefore, it is a very useful application for some uses because it doesn't have the response time problem.

Figure 3: AM Demodulation Waveform.

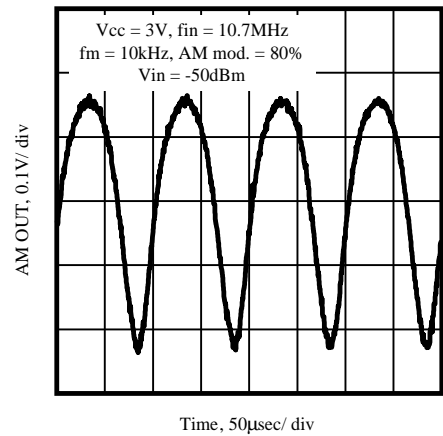
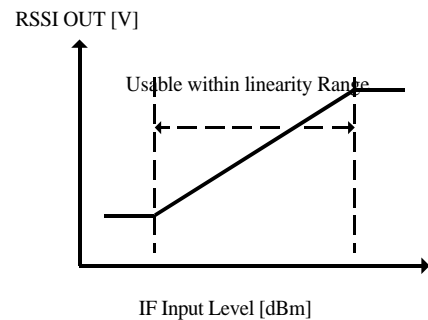

Figure 4: AM Demodulating Range with RSSI



13. NOTES

■ Please be sure that you carefully discuss your planned purchase with our office if you intend to use the products in this application manual under conditions where particularly extreme standards of reliability are required, or if you intend to use products for applications other than those listed in this application manual.

- Power drive products for automobile, ship or aircraft transport systems; steering and navigation systems, emergency signal communications systems, and any system other than those mentioned above which include electronic sensors, measuring, or display devices, and which could cause major damage to life, limb or property if misused or failure to function.

- Medical devices for measuring blood pressure, pulse, etc., treatment units such as coronary pacemakers and heat treatment units, and devices such as artificial organs and artificial limb systems which augment physiological functions.

- Electrical instruments, equipment or systems used in disaster or crime prevention.

■ Semiconductors, by nature, may fail or malfunction in spite of our devotion to improve product quality and reliability. We urge you to take every possible precaution against physical injuries, fire or other damages which may cause failure of our semiconductor products by taking appropriate measures, including a reasonable safety margin, malfunction preventive practices and fire-proofing when designing your products.

■ This application manual is effective from Mar.2002. Note that the contents are subject to change or discontinuation without notice. When placing orders, please confirm specifications and delivery condition in writing.

■ TOKO is not responsible for any problems nor for any infringement of third party patents or any other intellectual property rights that may arise from the use or method of use of the products listed in this application manual. Moreover, this application manual does not signify that TOKO agrees implicitly or explicitly to license any patent rights or other intellectual property rights which it holds.

■ None of ozone depleting substances(ODS) under the Montreal Protocol is used in manufacturing process of us.

14. OFFICES

If you need more information on this product and other TOKO products, please contact us.

■ TOKO Inc. Headquarters
 1-17, Higashi-yukigaya 2-chome, Ohta-ku, Tokyo,
 145-8585, Japan
 TEL: +81.3.3727.1161
 FAX: +81.3.3727.1176 or +81.3.3727.1169
 Web site: <http://www.toko.co.jp/>

■ TOKO America
 Web site: <http://www.toko.com/>

■ TOKO Europe
 Web site: <http://www.tokoeurope.com/>

■ TOKO Hong Kong
 Web site: <http://www.toko.com.hk/>

■ TOKO Taiwan
 Web site: <http://www.tokohc.com.tw/>

■ TOKO Singapore
 Web site: <http://www.toko.com.sg/>

■ TOKO Seoul
 Web site: <http://www.toko.co.kr/>

■ TOKO Manila
 Web site: <http://www.toko.com.ph/>

■ TOKO Brazil
 Web site: <http://www.toko.com.br/>



TO BUILD THE QUALITY RELIED BY COSTOMERS
Semiconductor Division

YOUR DISTRIBUTOR