

DATA SHEET

TDA9956

10-bit, 3.0 V, 36 Msps
analog-to-digital interface for CCD
cameras

Objective specification
File under Integrated Circuits, IC02

2000 Jul 20

10-bit, 3.0 V, 36 Msps analog-to-digital interface for CCD cameras

TDA9956

FEATURES

- Correlated Double Sampling (CDS), Programmable Gain Amplifier (PGA), 10-bit Analog-to-Digital Converter (ADC) and reference regulator included
- Fully programmable via a 3-wire serial interface
- Sampling frequency up to 36 MHz
- PGA gain range of 36 dB (in steps of 0.1 dB)
- Low power consumption of only 165 mW at 2.7 V
- Power consumption in standby mode of 4.5 mW (typ.)
- 3.0 V operation and 2.5 to 3.6 V operation for the digital outputs
- All digital inputs accept 5 V signals
- Active control pulses polarity selectable via serial interface
- 8-bit DAC included for analog settings
- TTL compatible inputs, CMOS compatible outputs.

APPLICATIONS

- Low-power, low-voltage CCD camera systems.

GENERAL DESCRIPTION

The TDA9956 is a 10-bit analog-to-digital interface for CCD cameras. The device includes a correlated double sampling circuit, PGA, clamp loops and a low-power 10-bit ADC together with its reference voltage regulator.

The PGA gain and the ADC input clamp level are controlled via the serial interface.

An additional DAC is provided for additional system controls; its output voltage range is 1.0 V (p-p) which is available at pin OFDOUT.

ORDERING INFORMATION

TYPE NUMBER	PACKAGE		
	NAME	DESCRIPTION	VERSION
TDA9956HL	LQFP48	plastic low profile quad flat package; 48 leads; body 7 × 7 × 1.4 mm	SOT313-2

10-bit, 3.0 V, 36 Msps analog-to-digital interface for CCD cameras

TDA9956

QUICK REFERENCE DATA

SYMBOL	PARAMETER	CONDITIONS	MIN.	TYP.	MAX.	UNIT
V_{CCA}	analog supply voltage		2.7	3.0	3.6	V
V_{CCD}	digital supply voltage		2.7	3.0	3.6	V
V_{CCO}	digital outputs supply voltage		2.2	2.5	3.6	V
I_{CCA}	analog supply current	all clamps active	–	57	–	mA
I_{CCD}	digital supply current		–	6	–	mA
I_{CCO}	digital outputs supply current	$f_{pix} = 36$ MHz; $C_L = 10$ pF; input ramp response time is 800 μ s	–	0.5	–	mA
ADC_{res}	ADC resolution		–	10	–	bits
$V_{i(CDS)(p-p)}$	maximum CDS input voltage (peak-to-peak value)	$V_{CC} = 2.85$ V	650	–	–	mV
		$V_{CC} \geq 3.0$ V	800	–	–	mV
$f_{pix(max)}$	maximum pixel rate		36	–	–	MHz
$f_{pix(min)}$	minimum pixel rate		tbf	–	–	MHz
DR_{PGA}	PGA dynamic range		–	36	–	dB
$N_{tot(rms)}$	total noise from CDS input to ADC output (RMS value)	PGA code = 00; see Fig.8	–	0.3	–	LSB
$E_{in(rms)}$	equivalent input noise (RMS value)	PGA code = 383	–	70	–	μ V
P_{tot}	total power consumption	$V_{CCA} = V_{CCD} = V_{CCO} = 3$ V	–	185	–	mW
		$V_{CCA} = V_{CCD} = V_{CCO} = 2.7$ V	–	165	–	mW

10-bit, 3.0 V, 36 Msps analog-to-digital interface for CCD cameras

TDA9956

BLOCK DIAGRAM

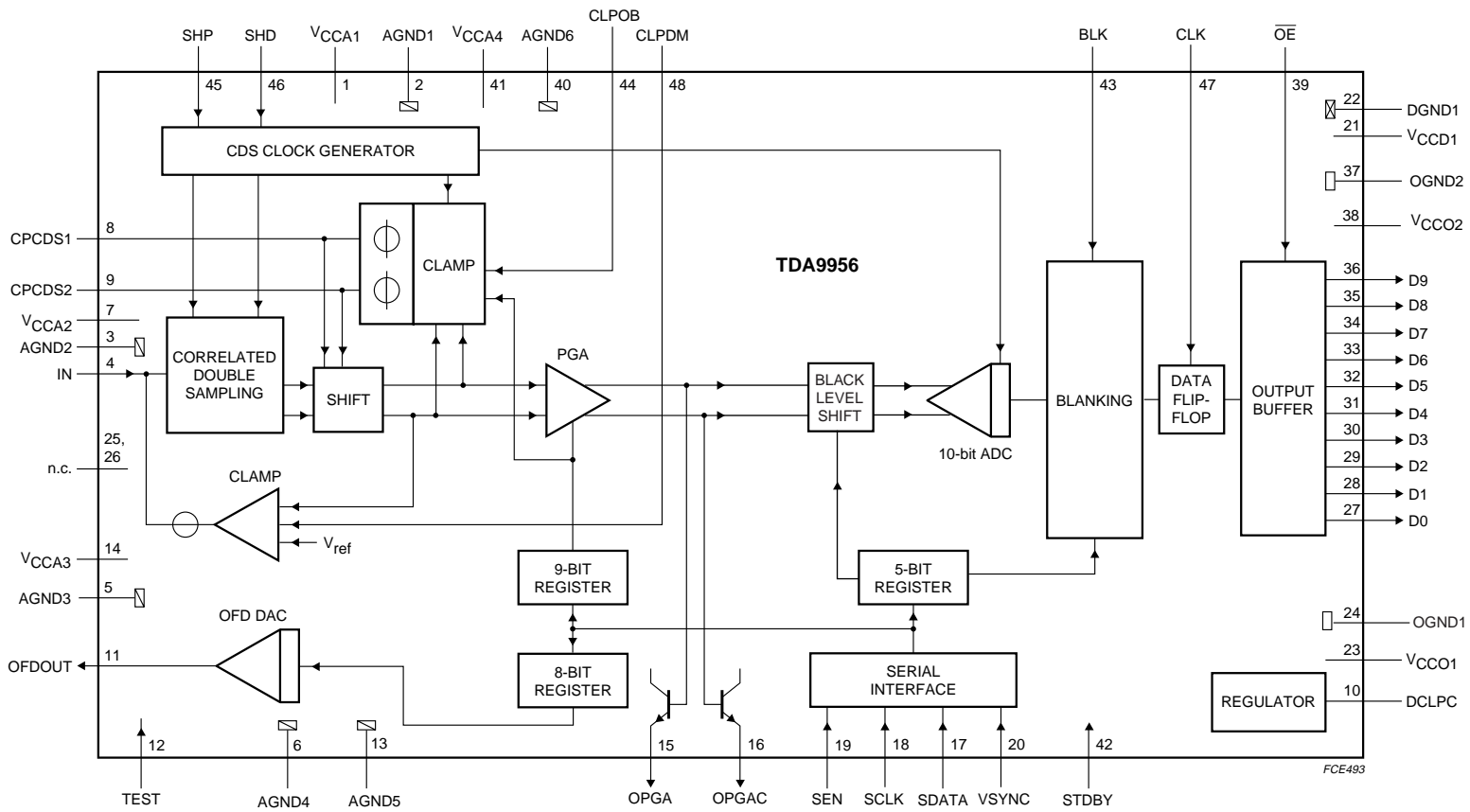

Fig.1 Block diagram.

10-bit, 3.0 V, 36 Msps analog-to-digital interface for CCD cameras

TDA9956

PINNING

SYMBOL	PIN	DESCRIPTION
V _{CCA1}	1	analog supply voltage 1
AGND1	2	analog ground 1
AGND2	3	analog ground 2
IN	4	input signal from CCD
AGND3	5	analog ground 3
AGND4	6	analog ground 4
V _{CCA2}	7	analog supply voltage 2
CPCDS1	8	clamp storage capacitor pin 1
CPCDS2	9	clamp storage capacitor pin 2
DCLPC	10	regulator decoupling pin
OFDOUT	11	analog output of the additional 8-bit control DAC
TEST	12	test mode input pin (should be connected to AGND5)
AGND5	13	analog ground 5
V _{CCA3}	14	analog supply voltage 3
OPGA	15	PGA output (test pin)
OPGAC	16	PGA complementary output (test pin)
SDATA	17	serial data input for serial interface control
SCLK	18	serial clock input for serial interface
SEN	19	strobe pin for serial interface
VSYNC	20	vertical sync pulse input
V _{CCD1}	21	digital supply voltage 1
DGND1	22	digital ground 1
V _{CCO1}	23	digital output supply voltage 1
OGND1	24	digital output ground 1
n.c.	25	not connected
n.c.	26	not connected
D0	27	ADC digital output 0 (LSB)
D1	28	ADC digital output 1
D2	29	ADC digital output 2
D3	30	ADC digital output 3
D4	31	ADC digital output 4
D5	32	ADC digital output 5
D6	33	ADC digital output 6
D7	34	ADC digital output 7
D8	35	ADC digital output 8
D9	36	ADC digital output 9 (MSB)
OGND2	37	digital output ground 2
V _{CCO2}	38	digital output supply voltage 2
$\overline{\text{OE}}$	39	output enable control input (LOW: outputs active; HIGH: outputs in high-impedance)
AGND6	40	analog ground 6

10-bit, 3.0 V, 36 Msps analog-to-digital interface for CCD cameras

TDA9956

SYMBOL	PIN	DESCRIPTION
V _{CCA4}	41	analog supply voltage 4
STDBY	42	standby mode control input (LOW = TDA9956 active; HIGH = TDA9956 standby)
BLK	43	blanking control input
CLPOB	44	clamp pulse input at optical black
SHP	45	preset sample-and-hold pulse input
SHD	46	data sample-and-hold pulse input
CLK	47	data clock input
CLPDM	48	clamp pulse input at dummy pixel

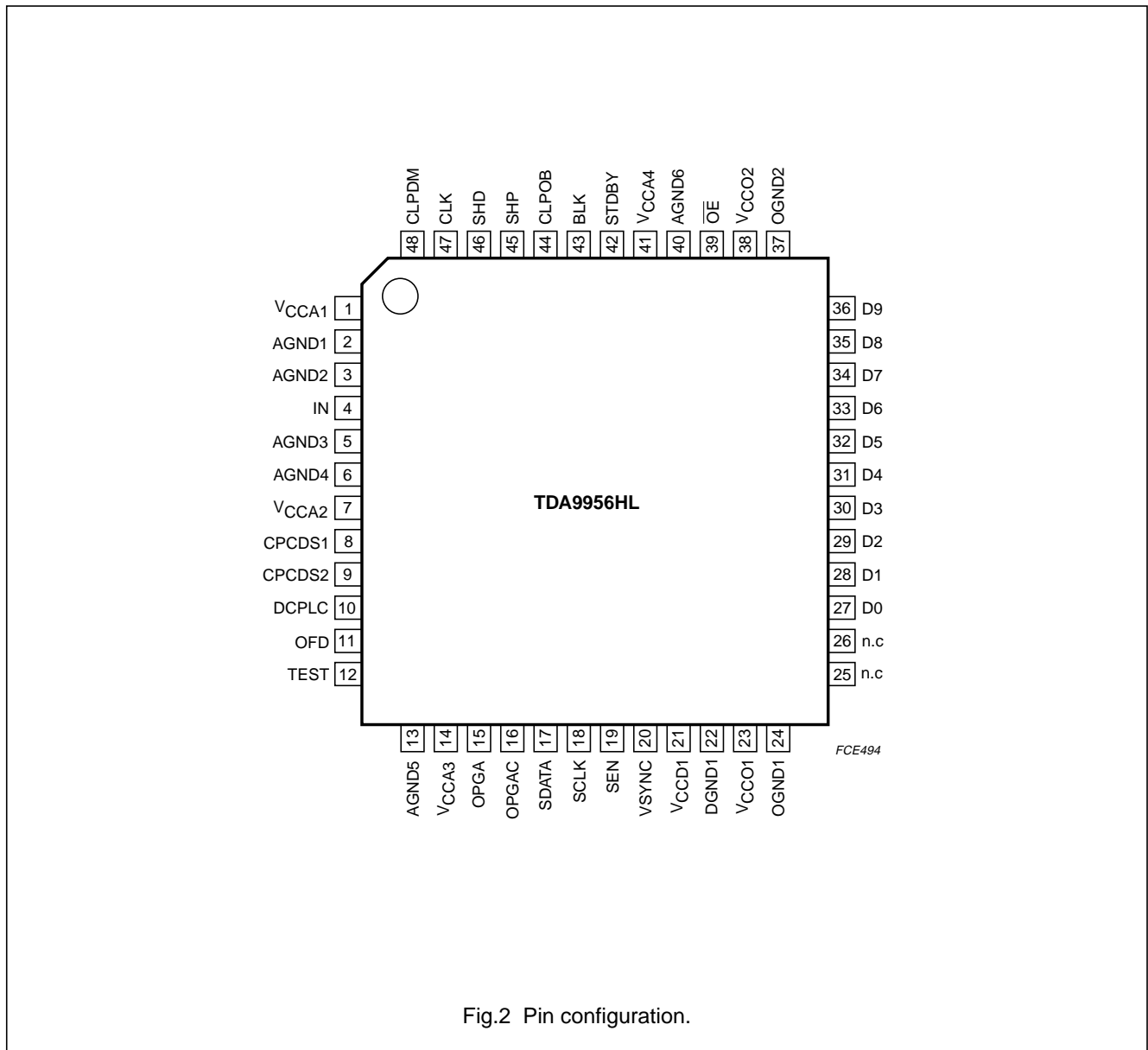

Fig.2 Pin configuration.

10-bit, 3.0 V, 36 Msps analog-to-digital interface for CCD cameras

TDA9956

LIMITING VALUES

In accordance with the Absolute Maximum Rating System (IEC 60134).

SYMBOL	PARAMETER	CONDITIONS	MIN.	MAX.	UNIT
V_{CCA}	analog supply voltage	note 1	-0.3	+7.0	V
V_{CCD}	digital supply voltage	note 1	-0.3	+7.0	V
V_{CCO}	digital outputs supply voltage	note 1	-0.3	+7.0	V
ΔV_{CC}	supply voltage difference between V_{CCA} and V_{CCD} between V_{CCA} and V_{CCO} between V_{CCD} and V_{CCO}		-0.5 -0.5 -0.5	+0.5 +1.2 +1.2	V V V
V_i	input voltage	referenced to AGND	-0.3	+7.0	V
I_o	data output current		-	± 10	mA
T_{stg}	storage temperature		-55	+150	°C
T_{amb}	ambient temperature		-20	+75	°C
T_j	junction temperature		-	150	°C

Note

- The supply voltages V_{CCA} , V_{CCD} and V_{CCO} may have any value between -0.3 and +7.0 V provided that the supply voltage difference ΔV_{CC} remains as indicated.

HANDLING

Inputs and outputs are protected against electrostatic discharges in normal handling. However, to be totally safe, it is desirable to take normal precautions appropriate to handling integrated circuits.

THERMAL CHARACTERISTICS

SYMBOL	PARAMETER	CONDITIONS	VALUE	UNIT
$R_{th(j-a)}$	thermal resistance from junction to ambient	in free air	76	K/W

10-bit, 3.0 V, 36 Msps analog-to-digital interface for CCD cameras

TDA9956

CHARACTERISTICS

$V_{CCA} = V_{CCD} = 3.0\text{ V}$; $V_{CCO} = 2.7\text{ V}$; $f_{\text{pix}} = 36\text{ MHz}$; $T_{\text{amb}} = 25\text{ °C}$; unless otherwise specified.

SYMBOL	PARAMETER	CONDITIONS	MIN.	TYP.	MAX.	UNIT
Supplies						
V_{CCA}	analog supply voltage		2.7	3.0	3.6	V
V_{CCD}	digital supply voltage		2.7	3.0	3.6	V
V_{CCO}	digital outputs supply voltage		2.2	2.5	3.6	V
I_{CCA}	analog supply current	all clamps active	–	57	–	mA
I_{CCD}	digital supply current		–	6	–	mA
I_{CCO}	digital outputs supply current	$C_L = 10\text{ pF}$ on all data outputs; input ramp response time is $800\text{ }\mu\text{s}$	–	0.5	–	mA
Digital inputs						
PINS SHP, SHD AND CLK (REFERENCED TO DGND)						
V_{IL}	LOW-level input voltage		0	–	0.6	V
V_{IH}	HIGH-level input voltage		2.2	–	5.5	V
I_i	input current	$0 \leq V_i \leq 5.5\text{ V}$	–3	–	+3	μA
Z_i	input impedance	$f_{\text{CLK}} = 36\text{ MHz}$	–	50	–	$\text{k}\Omega$
C_i	input capacitance	$f_{\text{CLK}} = 36\text{ MHz}$	–	–	2	pF
PINS CLPDM, CLPOB, SEN, SCLK, SDATA, STBY, OE, BLK AND VSYNC						
V_{IL}	LOW-level input voltage		0	–	0.6	V
V_{IH}	HIGH-level input voltage		2.2	–	5.5	V
I_i	input current	$0 \leq V_i \leq 5.5\text{ V}$	–2	–	+2	μA
Clamps						
GLOBAL CHARACTERISTICS OF THE CLAMP LOOPS						
$t_{W(\text{clamp})}$	clamp active pulse width in number of pixels	PGA code = 383 for maximum 4 LSB error	12	–	–	pixels
INPUT CLAMP (DRIVEN BY CLPDM)						
$g_{m(\text{CDS})}$	CDS input clamp transconductance		–	10	–	mS
Correlated Double Sampling (CDS)						
$V_{i(\text{CDS})(\text{p-p})}$	maximum peak-to-peak CDS input amplitude (video signal)	$V_{CC} = 2.85\text{ V}$	650	–	–	mV
		$V_{CC} \geq 3.0\text{ V}$	800	–	–	mV
$V_{\text{reset}(\text{max})}$	maximum CDS input reset pulse amplitude		500	–	–	mV
$I_{i(\text{IN})}$	input current into pin IN	at floating gate level	tbf	–	tbf	μA
C_i	input capacitance		–	2	–	pF

10-bit, 3.0 V, 36 Msps analog-to-digital interface for CCD cameras

TDA9956

SYMBOL	PARAMETER	CONDITIONS	MIN.	TYP.	MAX.	UNIT
$t_{\text{CDS(min)}}$	CDS control pulses minimum active time	$V_{i(\text{CDS})(\text{p-p})} = 800 \text{ mV}$ black-to-white transition in 1 pixel with 99% V_i recovery	7	–	–	ns
$t_{\text{h(IN;SHP)}}$	CDS input hold time (pin IN) compared to control pulse SHP	$V_{\text{CCA}} = V_{\text{CCD}} = 3.0 \text{ V};$ $T_{\text{amb}} = 25 \text{ }^\circ\text{C};$ see Figs 3 and 4	–	1	2	ns
$t_{\text{h(IN;SHD)}}$	CDS input hold time (pin IN) compared to control pulse SHD	$V_{\text{CCA}} = V_{\text{CCD}} = 3.0 \text{ V};$ $T_{\text{amb}} = 25 \text{ }^\circ\text{C};$ see Figs 3 and 4	–	1	2	ns
Amplifier						
DR_{PGA}	PGA dynamic range		–	36	–	dB
$\Delta\text{G}_{\text{PGA}}$	PGA gain step		0.08	0.10	0.12	dB
Analog-to-Digital Converter (ADC)						
DNL	differential non linearity	$f_{\text{pix}} = 36 \text{ MHz};$ ramp input	–	± 0.5	± 0.9	LSB
Total chain characteristics (CDS + PGA + ADC)						
$f_{\text{pix(max)}}$	maximum pixel frequency		36	–	–	MHz
$f_{\text{pix(min)}}$	minimum pixel frequency		tbf	–	–	MHz
t_{CLKH}	CLK pulse width HIGH		12	–	–	ns
t_{CLKL}	CLK pulse width LOW		12	–	–	ns
$t_{\text{d(SHD;CLK)}}$	time delay between SHD and CLK	see Figs 3 and 4	10	–	–	ns
$t_{\text{su(BLK;SHD)}}$	set-up time of BLK compared to SHD	see Figs 3 and 4	5	–	–	ns
$V_{i(\text{IN})(\text{FS})}$	video input dynamic signal for ADC full-scale output	PGA code = 00	800	–	–	mV
		PGA code = 383	12.7	–	–	mV
$N_{\text{tot(rms)}}$	total noise from CDS input to ADC output (RMS value)	see Fig.8				
		PGA code = 00	–	0.3	–	LSB
		PGA code = 96	–	0.5	–	LSB
$E_{\text{in(rms)}}$	equivalent input noise voltage (RMS value)	PGA code = 383	–	70	–	μV
		PGA code = 96	–	145	–	μV
$O_{\text{CCD(max)}}$	maximum offset between CCD floating level and CCD dark pixel level		–100	–	+100	mV

10-bit, 3.0 V, 36 Msps analog-to-digital interface for CCD cameras

TDA9956

SYMBOL	PARAMETER	CONDITIONS	MIN.	TYP.	MAX.	UNIT
Digital-to-analog converter (OFDOUT DAC)						
$V_{\text{OFDOUT(p-p)}}$	additional 8-bit control DAC (OFD) output voltage (peak-to-peak value)	$R_i = 1 \text{ M}\Omega$	–	1.0	–	V
$V_{\text{OFDOUT(0)}}$	DC output voltage for code 0		–	AGND	–	V
$V_{\text{OFDOUT(255)}}$	DC output voltage for code 255		–	AGND + 1.0	–	V
T_{CDAC}	DAC output range temperature coefficient		–	250	–	ppm/°C
Z_{OFDOUT}	DAC output impedance		–	2000	–	Ω
I_{OFDOUT}	OFD output current drive	static	–	–	100	μA
Digital outputs ($f_{\text{pix}} = 36 \text{ MHz}$; $C_L = 10 \text{ pF}$); see Figs 3 and 4						
V_{OH}	HIGH-level output voltage	$I_{\text{OH}} = -1 \text{ mA}$	$V_{\text{CCO}} - 0.5$	–	V_{CCO}	V
V_{OL}	LOW-level output voltage	$I_{\text{OL}} = 1 \text{ mA}$	0	–	0.5	V
I_{OZ}	output current in 3-state mode	$0.5 \text{ V} < V_o < V_{\text{CCO}}$	–20	–	+20	μA
$t_{\text{h(o)}}$	output hold time		5	–	–	ns
$t_{\text{d(o)}}$	output delay time	$C_L = 10 \text{ pF}$; $V_{\text{CCO}} = 3.0 \text{ V}$	–	12	tbf	ns
		$C_L = 10 \text{ pF}$; $V_{\text{CCO}} = 2.7 \text{ V}$	–	14	tbf	ns
C_L	output load capacitance		–	–	15	pF
Serial interface						
$f_{\text{SCLK(max)}}$	maximum frequency of serial clock interface		10	–	–	MHz

10-bit, 3.0 V, 36 Msps analog-to-digital interface for CCD cameras

TDA9956

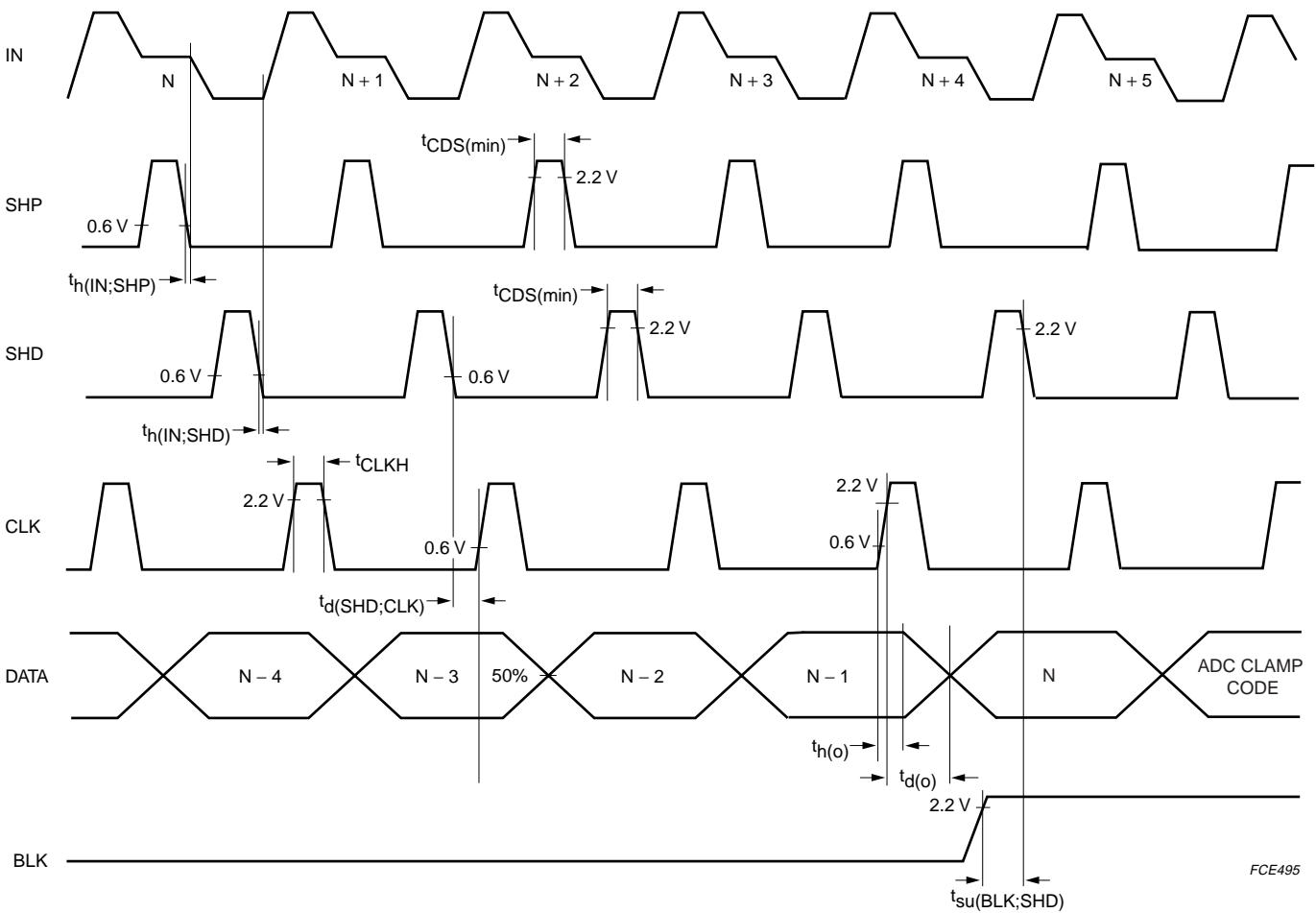

Fig.3 Pixel frequency timing diagram; all polarities active HIGH.

FCE495

10-bit, 3.0 V, 36 Msps analog-to-digital interface for CCD cameras

TDA9956

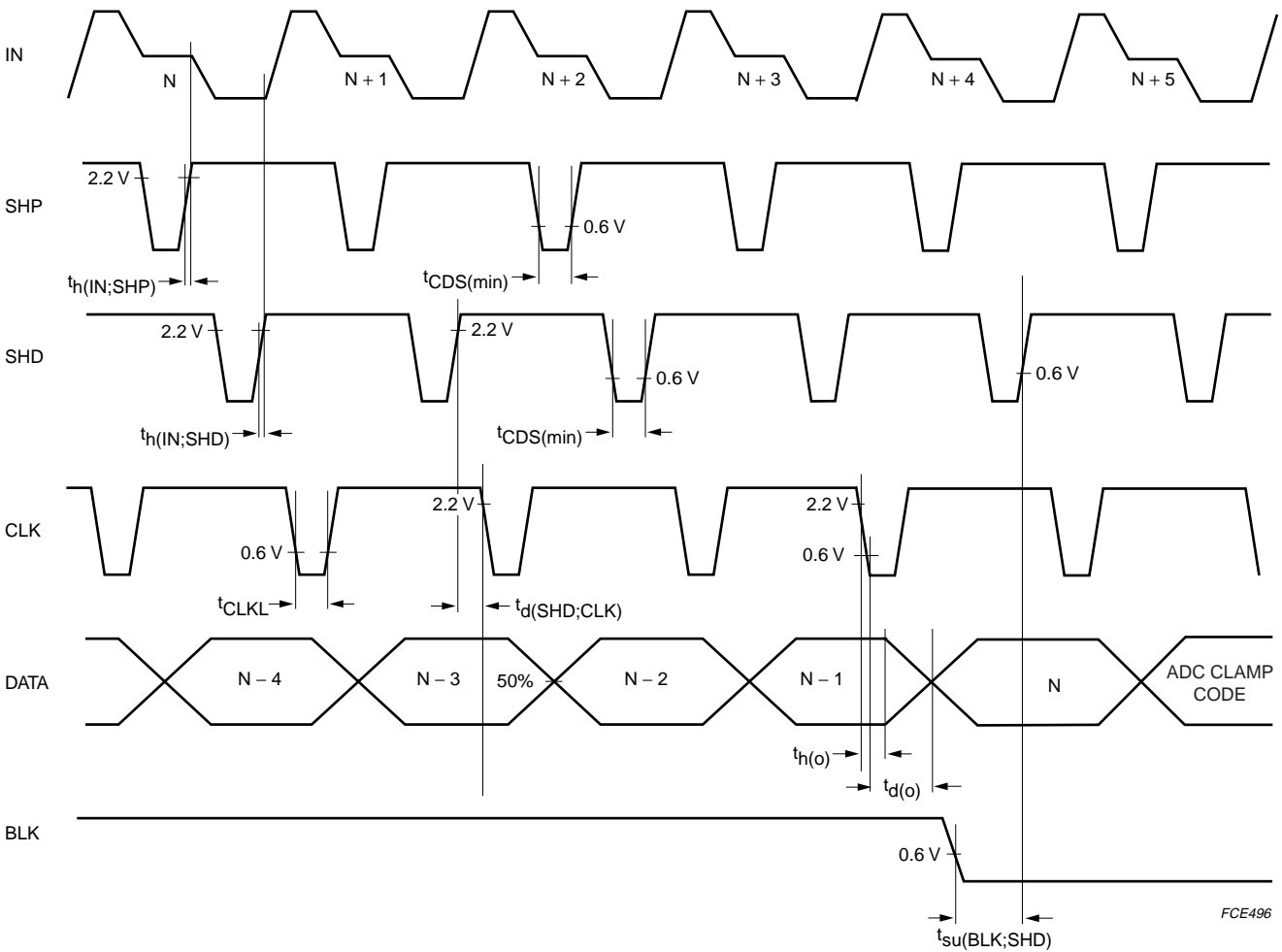

Fig.4 Pixel frequency timing diagram; all polarities active LOW.

10-bit, 3.0 V, 36 Msp/s analog-to-digital interface for CCD cameras

TDA9956

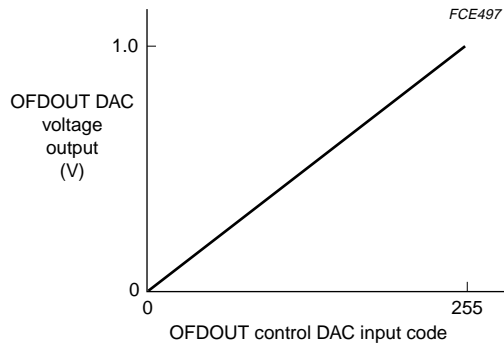

Fig.5 DAC voltage output as a function of DAC input code.

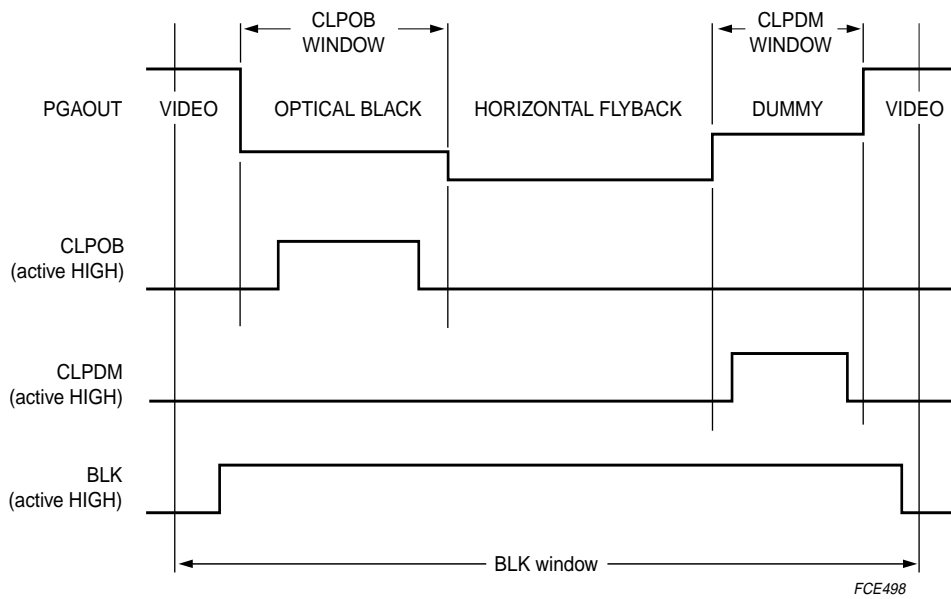

Fig.6 Line frequency timing diagram.

10-bit, 3.0 V, 36 Msp/s analog-to-digital interface for CCD cameras

TDA9956

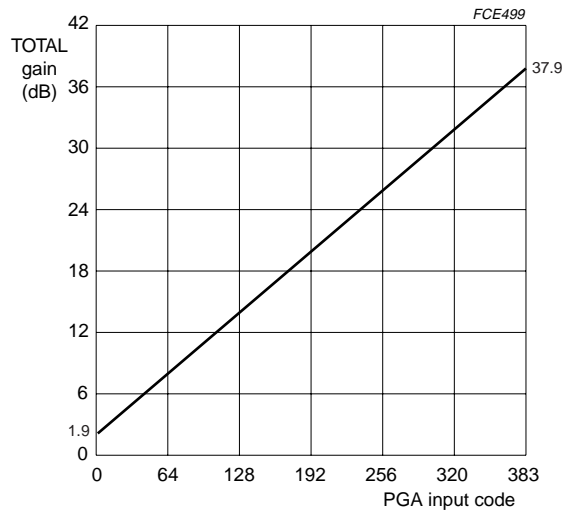
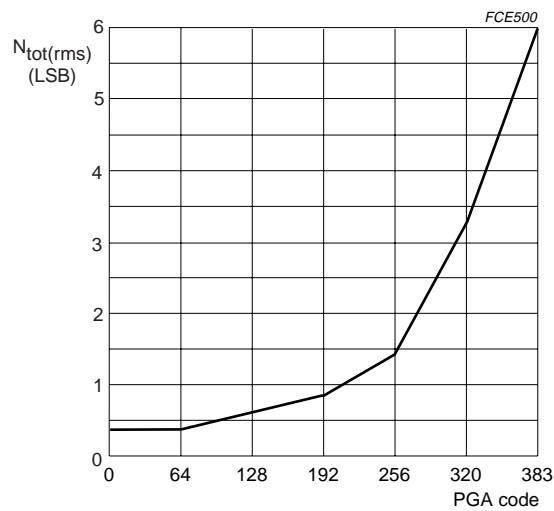

Fig.7 Total gain from CDS input to ADC input as a function of PGA input code.



Noise measurement at ADC outputs:

Coupling capacitor at input is grounded, so only noise contribution of the front-end is evaluated. Front-end works at 36 Mpixels with line of 1 024 pixels whose first 40 are used to run CLPOB and the last 40 for CLPDM. Data at the ADC outputs are measured during the other pixels. As a result of this, the standard deviation of the codes statistic is computed, resulting in the noise. No quantization noise is taken into account as there is no input.

Fig.8 Typical total noise performance as a function of PGA gain.

10-bit, 3.0 V, 36 Msp/s analog-to-digital interface for CCD cameras

TDA9956

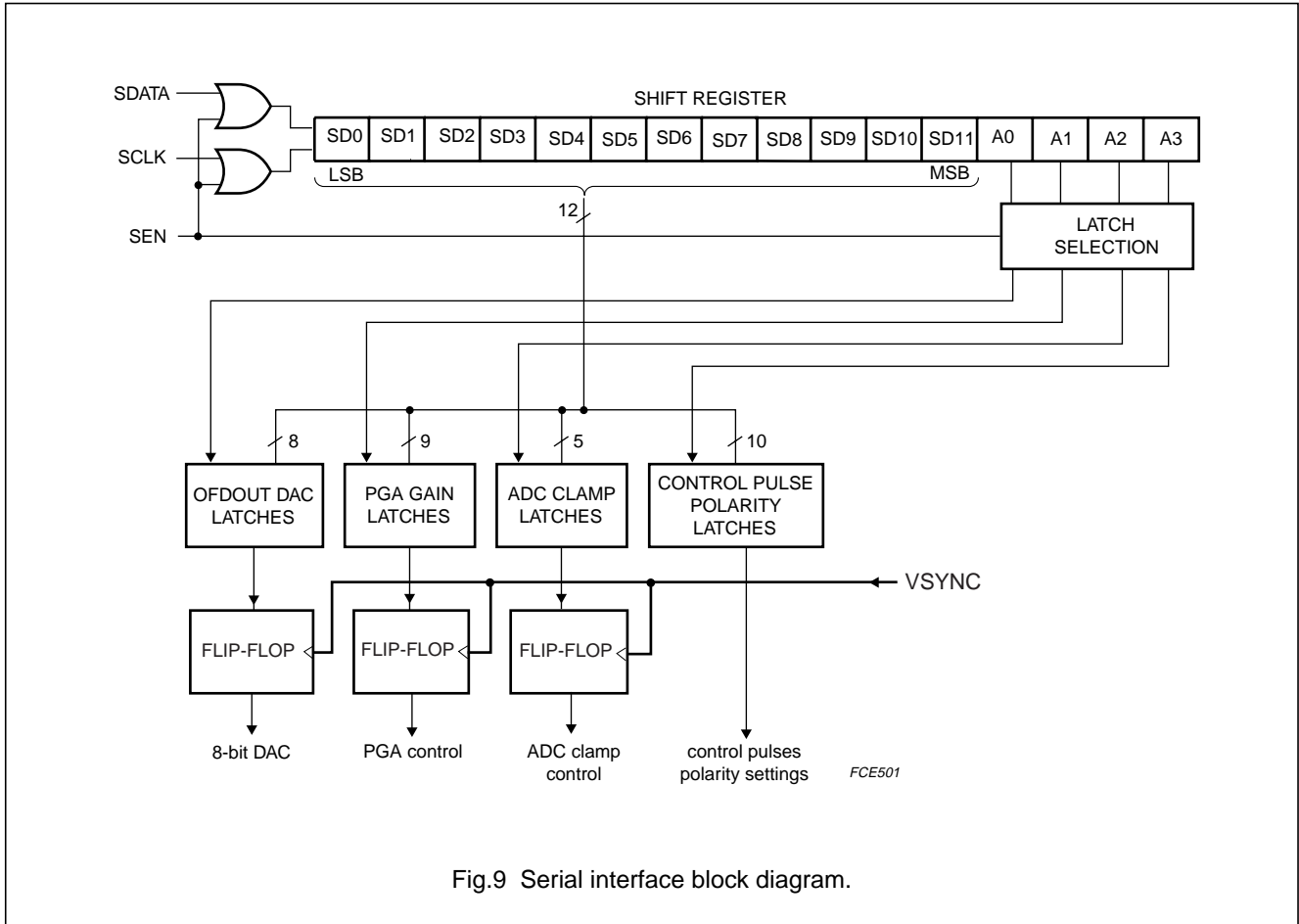

Fig.9 Serial interface block diagram.

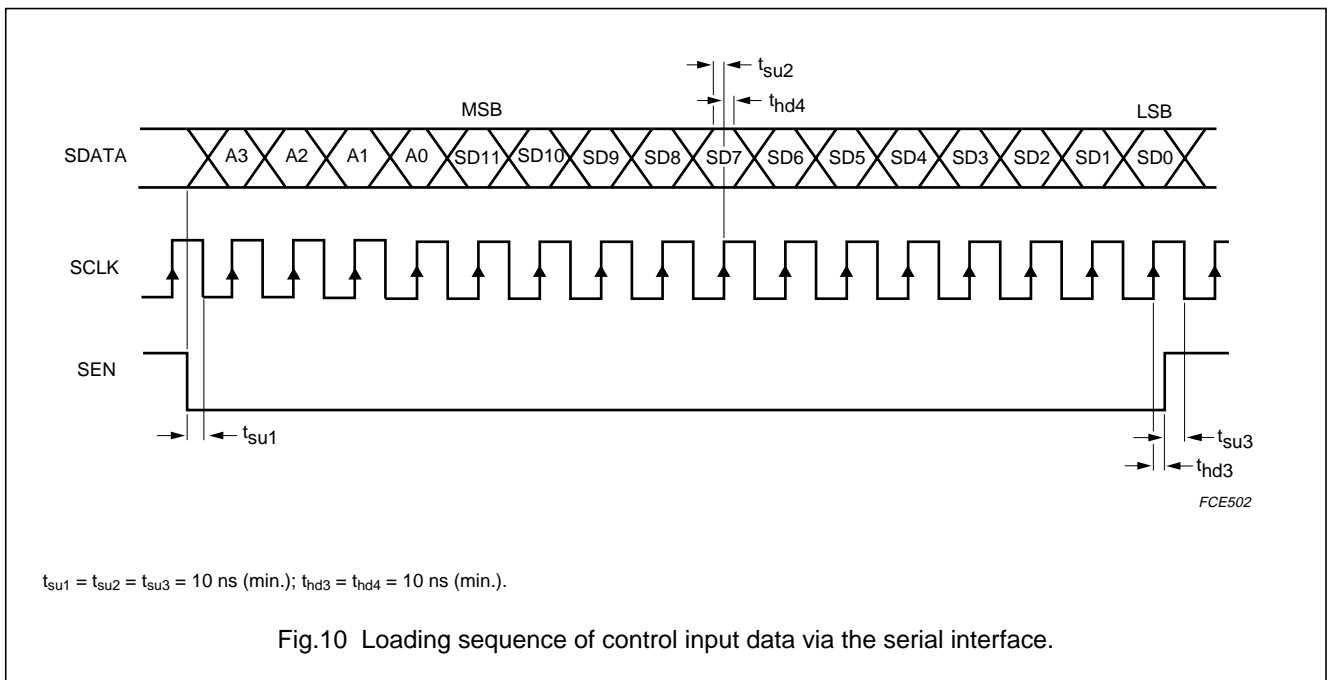

Fig.10 Loading sequence of control input data via the serial interface.

10-bit, 3.0 V, 36 Msps analog-to-digital interface for CCD cameras

TDA9956

Table 1 Serial interface programming

ADDRESS BITS				DATA BITS SD11 TO SD0
A3	A2	A1	A0	
0	0	0	0	PGA gain control (SD8 to SD0)
0	0	0	1	DAC OFDOUT output control (SD7 to SD0)
0	0	1	0	ADC clamp reference control (SD4 to SD0); from code 0 to code 31
0	0	1	1	control pulses (pins SHP, SHD, CLPDM, CLPOB, BLK and CLK) polarity settings; SD2, SD6, SD7 and SD9 should be set to logic 1; for SD6 and SD7 see Tables 3 and 4
1	1	1	1	initialization (SD11 to SD9 = 0)
other addresses				test modes

Table 2 Polarity settings

SYMBOL	PIN	SERIAL CONTROL BIT	ACTIVE EDGE OR LEVEL
SHP and SHD	45 and 46	SD4	1 = HIGH; 0 = LOW
CLK	47	SD5	1 = rising; 0 = falling
CLPDM	48	SD0	1 = HIGH; 0 = LOW
CLPOB	44	SD1	1 = HIGH; 0 = LOW
BLK	43	SD3	1 = HIGH; 0 = LOW
VSYNC	20	SD8	0 = rising; 1 = falling

Table 3 Standby control using STDBY pin or serial interface (register address A3 = 0, A2 = 0, A1 = 1 and A0 = 1)

BIT SD7 OF REGISTER	STDBY	I _{CCA} + I _{CCO} + I _{CCD} (typ.)
1	1	1.5 mA
	0	63 mA
0	1	63 mA
	0	1.5 mA

10-bit, 3.0 V, 36 Msps analog-to-digital interface for CCD cameras

TDA9956

Table 4 Output enable selection using output enable pin (\overline{OE}) or serial interface (register address A3 = 0, A2 = 0, A1 = 1 and A0 = 1)

BIT SD6 OF REGISTER 0011	\overline{OE}	ADC DIGITAL OUTPUTS D9 TO D0
1	0	active, binary
	1	high-impedance
0	0	high-impedance
	1	active binary

Table 5 Standby control by serial interface (register address A3 = 0, A2 = 0, A1 = 1, A0 = 1); STDBY pin connected to ground

SD7	ADC DIGITAL OUTPUTS SD11 TO SD0	$I_{CCA} + I_{CCO} + I_{CCD}$ (typ.)
0	last logic state	1.5 mA
1	active	64 mA

Table 6 Output enable control by serial interface (register address A3 = 0, A2 = 0, A1 = 1, A0 = 1); output enable pin (\overline{OE}) connected to ground

SD6	ADC DIGITAL OUTPUTS D9 TO D0
0	high-impedance
1	active binary

10-bit, 3.0 V, 36 Msp/s analog-to-digital interface for CCD cameras

TDA9956

APPLICATION DIAGRAM

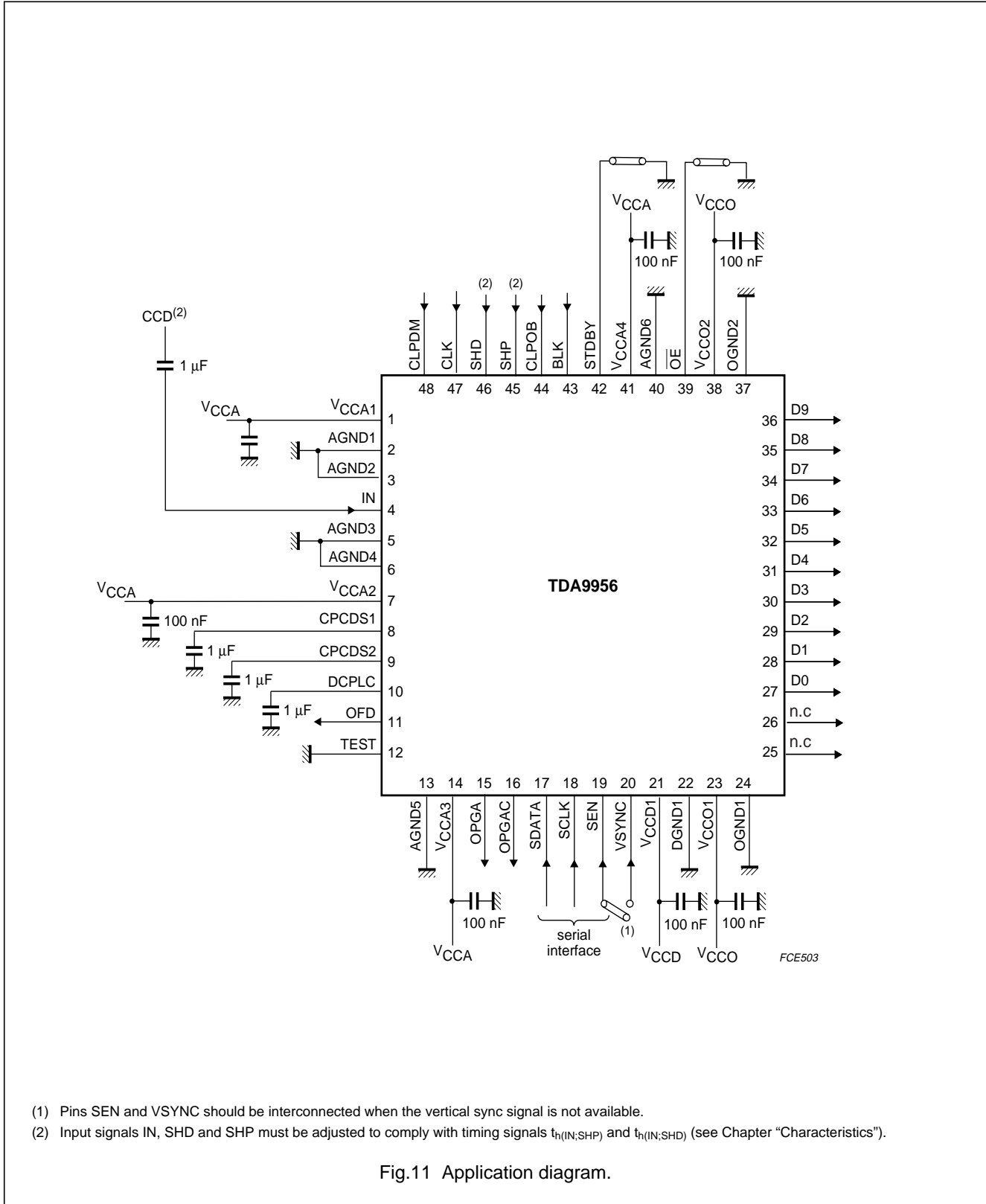

10-bit, 3.0 V, 36 Msps analog-to-digital interface for CCD cameras

TDA9956

Power and grounding recommendations

When designing a printed-circuit board for applications such as PC cameras, surveillance cameras, camcorders and digital still cameras, care should be taken to minimize the noise.

For the front-end integrated circuit, the basic rules of printed-circuit board design and implementation of analog components (such as classical operational amplifiers) must be respected, particularly with respect to power and ground connections.

The following additional recommendation is given for the CDS input pin(s) which is/are internally connected to the programmable gain amplifier:

The connections between the CCD interface and the CDS input should be as short as possible and a ground ring protection around these connections can be beneficial. Separate analog and digital supplies provide the best solution. If it is not possible to do this on the board then the analog supply pins must be decoupled effectively from the digital supply pins. If the same power supply and ground are used for all the pins then the decoupling capacitors must be placed as close as possible to the IC package.

In a two-ground system, in order to minimize the noise through package and die parasitics, the following recommendation must be implemented.

All the analog and digital supply pins must be decoupled to the analog ground plane. Only the ground pin associated with the digital outputs must be connected to the digital ground plane. All the other ground pins should be connected to the analog ground plane. The analog and digital ground planes must be connected together at one point as close as possible to the ground pin associated with the digital outputs.

The digital output pins and their associated lines should be shielded by the digital ground plane which can then be used as a return path for digital signals.

10-bit, 3.0 V, 36 Msps analog-to-digital interface for CCD cameras

TDA9956

PACKAGE OUTLINE

LQFP48: plastic low profile quad flat package; 48 leads; body 7 x 7 x 1.4 mm

SOT313-2

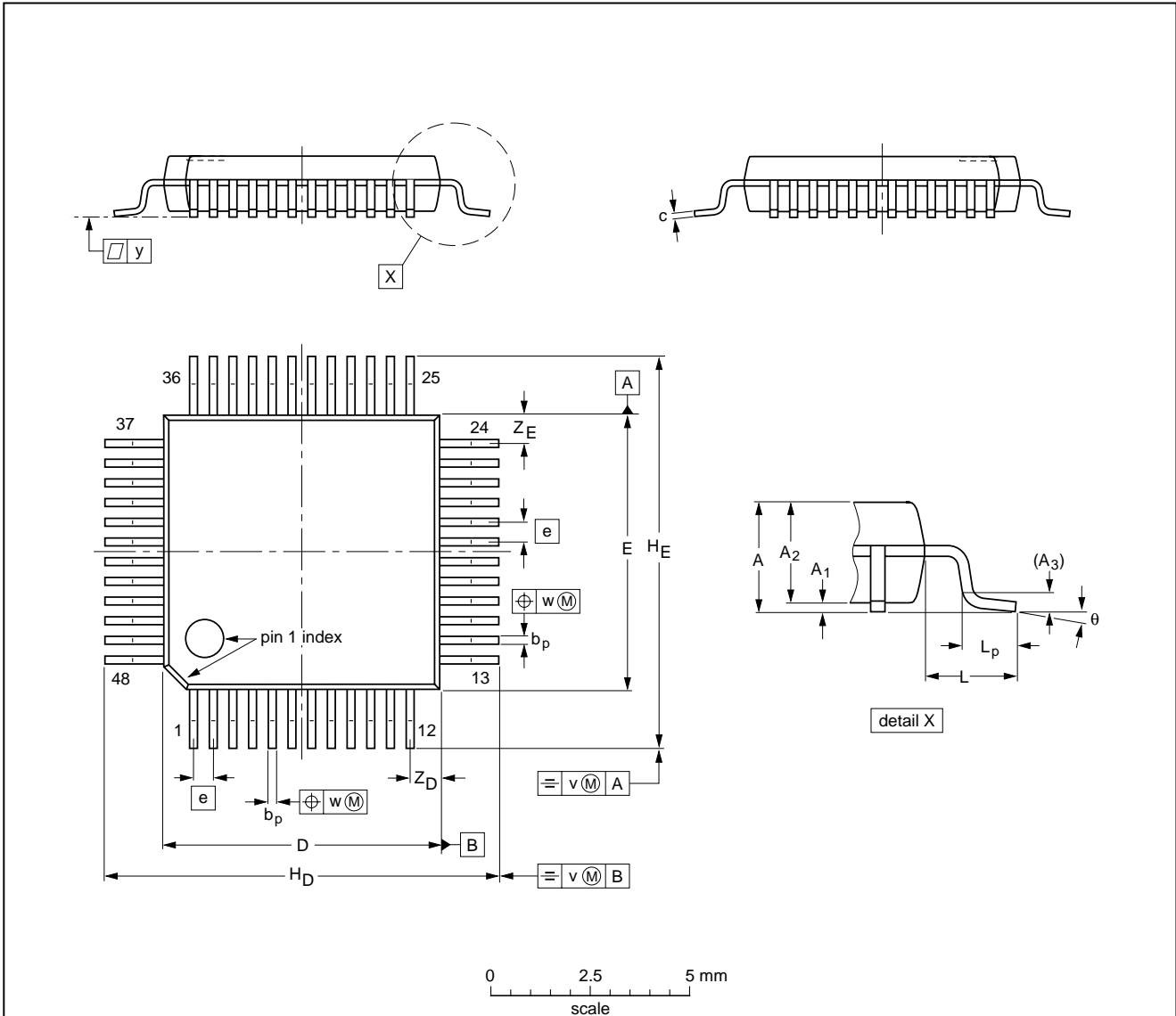

DIMENSIONS (mm are the original dimensions)

UNIT	A max.	A ₁	A ₂	A ₃	b _p	c	D ⁽¹⁾	E ⁽¹⁾	e	H _D	H _E	L	L _p	v	w	y	Z _D ⁽¹⁾	Z _E ⁽¹⁾	θ
mm	1.60	0.20 0.05	1.45 1.35	0.25	0.27 0.17	0.18 0.12	7.1 6.9	7.1 6.9	0.5	9.15 8.85	9.15 8.85	1.0	0.75 0.45	0.2	0.12	0.1	0.95 0.55	0.95 0.55	7° 0°

Note

1. Plastic or metal protrusions of 0.25 mm maximum per side are not included.

OUTLINE VERSION	REFERENCES				EUROPEAN PROJECTION	ISSUE DATE
	IEC	JEDEC	EIAJ			
SOT313-2	136E05	MS-026				99-12-27 00-01-19

10-bit, 3.0 V, 36 Msps analog-to-digital interface for CCD cameras

TDA9956

SOLDERING

Introduction to soldering surface mount packages

This text gives a very brief insight to a complex technology. A more in-depth account of soldering ICs can be found in our *"Data Handbook IC26; Integrated Circuit Packages"* (document order number 9398 652 90011).

There is no soldering method that is ideal for all surface mount IC packages. Wave soldering is not always suitable for surface mount ICs, or for printed-circuit boards with high population densities. In these situations reflow soldering is often used.

Reflow soldering

Reflow soldering requires solder paste (a suspension of fine solder particles, flux and binding agent) to be applied to the printed-circuit board by screen printing, stencilling or pressure-syringe dispensing before package placement.

Several methods exist for reflowing; for example, infrared/convection heating in a conveyor type oven. Throughput times (preheating, soldering and cooling) vary between 100 and 200 seconds depending on heating method.

Typical reflow peak temperatures range from 215 to 250 °C. The top-surface temperature of the packages should preferably be kept below 230 °C.

Wave soldering

Conventional single wave soldering is not recommended for surface mount devices (SMDs) or printed-circuit boards with a high component density, as solder bridging and non-wetting can present major problems.

To overcome these problems the double-wave soldering method was specifically developed.

If wave soldering is used the following conditions must be observed for optimal results:

- Use a double-wave soldering method comprising a turbulent wave with high upward pressure followed by a smooth laminar wave.
- For packages with leads on two sides and a pitch (e):
 - larger than or equal to 1.27 mm, the footprint longitudinal axis is **preferred** to be parallel to the transport direction of the printed-circuit board;
 - smaller than 1.27 mm, the footprint longitudinal axis **must** be parallel to the transport direction of the printed-circuit board.

The footprint must incorporate solder thieves at the downstream end.

- For packages with leads on four sides, the footprint must be placed at a 45° angle to the transport direction of the printed-circuit board. The footprint must incorporate solder thieves downstream and at the side corners.

During placement and before soldering, the package must be fixed with a droplet of adhesive. The adhesive can be applied by screen printing, pin transfer or syringe dispensing. The package can be soldered after the adhesive is cured.

Typical dwell time is 4 seconds at 250 °C.

A mildly-activated flux will eliminate the need for removal of corrosive residues in most applications.

Manual soldering

Fix the component by first soldering two diagonally-opposite end leads. Use a low voltage (24 V or less) soldering iron applied to the flat part of the lead. Contact time must be limited to 10 seconds at up to 300 °C.

When using a dedicated tool, all other leads can be soldered in one operation within 2 to 5 seconds between 270 and 320 °C.

**10-bit, 3.0 V, 36 Msps analog-to-digital
interface for CCD cameras**

TDA9956**Suitability of surface mount IC packages for wave and reflow soldering methods**

PACKAGE	SOLDERING METHOD	
	WAVE	REFLOW ⁽¹⁾
BGA, LFBGA, SQFP, TFBGA	not suitable	suitable
HBCC, HLQFP, HSQFP, HSOP, HTQFP, HTSSOP, SMS	not suitable ⁽²⁾	suitable
PLCC ⁽³⁾ , SO, SOJ	suitable	suitable
LQFP, QFP, TQFP	not recommended ⁽³⁾⁽⁴⁾	suitable
SSOP, TSSOP, VSO	not recommended ⁽⁵⁾	suitable

Notes

1. All surface mount (SMD) packages are moisture sensitive. Depending upon the moisture content, the maximum temperature (with respect to time) and body size of the package, there is a risk that internal or external package cracks may occur due to vaporization of the moisture in them (the so called popcorn effect). For details, refer to the Drypack information in the *"Data Handbook IC26; Integrated Circuit Packages; Section: Packing Methods"*.
2. These packages are not suitable for wave soldering as a solder joint between the printed-circuit board and heatsink (at bottom version) can not be achieved, and as solder may stick to the heatsink (on top version).
3. If wave soldering is considered, then the package must be placed at a 45° angle to the solder wave direction. The package footprint must incorporate solder thieves downstream and at the side corners.
4. Wave soldering is only suitable for LQFP, TQFP and QFP packages with a pitch (e) equal to or larger than 0.8 mm; it is definitely not suitable for packages with a pitch (e) equal to or smaller than 0.65 mm.
5. Wave soldering is only suitable for SSOP and TSSOP packages with a pitch (e) equal to or larger than 0.65 mm; it is definitely not suitable for packages with a pitch (e) equal to or smaller than 0.5 mm.

10-bit, 3.0 V, 36 Msps analog-to-digital interface for CCD cameras

TDA9956

DATA SHEET STATUS

DATA SHEET STATUS	PRODUCT STATUS	DEFINITIONS ⁽¹⁾
Objective specification	Development	This data sheet contains the design target or goal specifications for product development. Specification may change in any manner without notice.
Preliminary specification	Qualification	This data sheet contains preliminary data, and supplementary data will be published at a later date. Philips Semiconductors reserves the right to make changes at any time without notice in order to improve design and supply the best possible product.
Product specification	Production	This data sheet contains final specifications. Philips Semiconductors reserves the right to make changes at any time without notice in order to improve design and supply the best possible product.

Note

1. Please consult the most recently issued data sheet before initiating or completing a design.

DEFINITIONS

Short-form specification — The data in a short-form specification is extracted from a full data sheet with the same type number and title. For detailed information see the relevant data sheet or data handbook.

Limiting values definition — Limiting values given are in accordance with the Absolute Maximum Rating System (IEC 60134). Stress above one or more of the limiting values may cause permanent damage to the device. These are stress ratings only and operation of the device at these or at any other conditions above those given in the Characteristics sections of the specification is not implied. Exposure to limiting values for extended periods may affect device reliability.

Application information — Applications that are described herein for any of these products are for illustrative purposes only. Philips Semiconductors make no representation or warranty that such applications will be suitable for the specified use without further testing or modification.

DISCLAIMERS

Life support applications — These products are not designed for use in life support appliances, devices, or systems where malfunction of these products can reasonably be expected to result in personal injury. Philips Semiconductors customers using or selling these products for use in such applications do so at their own risk and agree to fully indemnify Philips Semiconductors for any damages resulting from such application.

Right to make changes — Philips Semiconductors reserves the right to make changes, without notice, in the products, including circuits, standard cells, and/or software, described or contained herein in order to improve design and/or performance. Philips Semiconductors assumes no responsibility or liability for the use of any of these products, conveys no licence or title under any patent, copyright, or mask work right to these products, and makes no representations or warranties that these products are free from patent, copyright, or mask work right infringement, unless otherwise specified.

Philips Semiconductors – a worldwide company

Argentina: see South America

Australia: 3 Figtree Drive, HOMEBUSH, NSW 2140,
Tel. +61 2 9704 8141, Fax. +61 2 9704 8139

Austria: Computerstr. 6, A-1101 WIEN, P.O. Box 213,
Tel. +43 1 60 101 1248, Fax. +43 1 60 101 1210

Belarus: Hotel Minsk Business Center, Bld. 3, r. 1211, Volodarski Str. 6,
220050 MINSK, Tel. +375 172 20 0733, Fax. +375 172 20 0773

Belgium: see The Netherlands

Brazil: see South America

Bulgaria: Philips Bulgaria Ltd., Energoproject, 15th floor,
51 James Bourchier Blvd., 1407 SOFIA,
Tel. +359 2 68 9211, Fax. +359 2 68 9102

Canada: PHILIPS SEMICONDUCTORS/COMPONENTS,
Tel. +1 800 234 7381, Fax. +1 800 943 0087

China/Hong Kong: 501 Hong Kong Industrial Technology Centre,
72 Tat Chee Avenue, Kowloon Tong, HONG KONG,
Tel. +852 2319 7888, Fax. +852 2319 7700

Colombia: see South America

Czech Republic: see Austria

Denmark: Sydhavnsgade 23, 1780 COPENHAGEN V,
Tel. +45 33 29 3333, Fax. +45 33 29 3905

Finland: Sinikalliontie 3, FIN-02630 ESPOO,
Tel. +358 9 615 800, Fax. +358 9 6158 0920

France: 51 Rue Carnot, BP317, 92156 SURESNES Cedex,
Tel. +33 1 4099 6161, Fax. +33 1 4099 6427

Germany: Hammerbrookstraße 69, D-20097 HAMBURG,
Tel. +49 40 2353 60, Fax. +49 40 2353 6300

Hungary: see Austria

India: Philips INDIA Ltd, Band Box Building, 2nd floor,
254-D, Dr. Annie Besant Road, Worli, MUMBAI 400 025,
Tel. +91 22 493 8541, Fax. +91 22 493 0966

Indonesia: PT Philips Development Corporation, Semiconductors Division,
Gedung Philips, Jl. Buncit Raya Kav.99-100, JAKARTA 12510,
Tel. +62 21 794 0040 ext. 2501, Fax. +62 21 794 0080

Ireland: Newstead, Clonskeagh, DUBLIN 14,
Tel. +353 1 7640 000, Fax. +353 1 7640 200

Israel: RAPAC Electronics, 7 Kehilat Saloniki St, PO Box 18053,
TEL AVIV 61180, Tel. +972 3 645 0444, Fax. +972 3 649 1007

Italy: PHILIPS SEMICONDUCTORS, Via Casati, 23 - 20052 MONZA (MI),
Tel. +39 039 203 6838, Fax +39 039 203 6800

Japan: Philips Bldg 13-37, Kohnan 2-chome, Minato-ku,
TOKYO 108-8507, Tel. +81 3 3740 5130, Fax. +81 3 3740 5057

Korea: Philips House, 260-199 Itaewon-dong, Yongsan-ku, SEOUL,
Tel. +82 2 709 1412, Fax. +82 2 709 1415

Malaysia: No. 76 Jalan Universiti, 46200 PETALING JAYA, SELANGOR,
Tel. +60 3 750 5214, Fax. +60 3 757 4880

Mexico: 5900 Gateway East, Suite 200, EL PASO, TEXAS 79905,
Tel. +9-5 800 234 7381, Fax +9-5 800 943 0087

Middle East: see Italy

Netherlands: Postbus 90050, 5600 PB EINDHOVEN, Bldg. VB,
Tel. +31 40 27 82785, Fax. +31 40 27 88399

New Zealand: 2 Wagener Place, C.P.O. Box 1041, AUCKLAND,
Tel. +64 9 849 4160, Fax. +64 9 849 7811

Norway: Box 1, Manglerud 0612, OSLO,
Tel. +47 22 74 8000, Fax. +47 22 74 8341

Pakistan: see Singapore

Philippines: Philips Semiconductors Philippines Inc.,
106 Valero St. Salcedo Village, P.O. Box 2108 MCC, MAKATI,
Metro MANILA, Tel. +63 2 816 6380, Fax. +63 2 817 3474

Poland: Al.Jerozolimskie 195 B, 02-222 WARSAW,
Tel. +48 22 5710 000, Fax. +48 22 5710 001

Portugal: see Spain

Romania: see Italy

Russia: Philips Russia, Ul. Usatcheva 35A, 119048 MOSCOW,
Tel. +7 095 755 6918, Fax. +7 095 755 6919

Singapore: Lorong 1, Toa Payoh, SINGAPORE 319762,
Tel. +65 350 2538, Fax. +65 251 6500

Slovakia: see Austria

Slovenia: see Italy

South Africa: S.A. PHILIPS Pty Ltd., 195-215 Main Road Martindale,
2092 JOHANNESBURG, P.O. Box 58088 Newville 2114,
Tel. +27 11 471 5401, Fax. +27 11 471 5398

South America: Al. Vicente Pinzon, 173, 6th floor,
04547-130 SÃO PAULO, SP, Brazil,
Tel. +55 11 821 2333, Fax. +55 11 821 2382

Spain: Balmes 22, 08007 BARCELONA,
Tel. +34 93 301 6312, Fax. +34 93 301 4107

Sweden: Kottbygatan 7, Akalla, S-16485 STOCKHOLM,
Tel. +46 8 5985 2000, Fax. +46 8 5985 2745

Switzerland: Allmendstrasse 140, CH-8027 ZÜRICH,
Tel. +41 1 488 2741 Fax. +41 1 488 3263

Taiwan: Philips Semiconductors, 5F, No. 96, Chien Kuo N. Rd., Sec. 1,
TAIPEI, Taiwan Tel. +886 2 2134 2451, Fax. +886 2 2134 2874

Thailand: PHILIPS ELECTRONICS (THAILAND) Ltd.,
60/14 MOO 11, Bangna Trad Road KM. 3, Bagna, BANGKOK 10260,
Tel. +66 2 361 7910, Fax. +66 2 398 3447

Turkey: Yukari Dudullu, Org. San. Blg., 2.Cad. Nr. 28 81260 Umraniye,
ISTANBUL, Tel. +90 216 522 1500, Fax. +90 216 522 1813

Ukraine: PHILIPS UKRAINE, 4 Patrice Lumumba str., Building B, Floor 7,
252042 KIEV, Tel. +380 44 264 2776, Fax. +380 44 268 0461

United Kingdom: Philips Semiconductors Ltd., 276 Bath Road, Hayes,
MIDDLESEX UB3 5BX, Tel. +44 208 730 5000, Fax. +44 208 754 8421

United States: 811 East Arques Avenue, SUNNYVALE, CA 94088-3409,
Tel. +1 800 234 7381, Fax. +1 800 943 0087

Uruguay: see South America

Vietnam: see Singapore

Yugoslavia: PHILIPS, Trg N. Pasica 5/v, 11000 BEOGRAD,
Tel. +381 11 3341 299, Fax.+381 11 3342 553

For all other countries apply to: Philips Semiconductors,
Marketing Communications, Building BE-p, P.O. Box 218, 5600 MD EINDHOVEN,
The Netherlands, Fax. +31 40 27 24825

Internet: <http://www.semiconductors.philips.com>

© Philips Electronics N.V. 2000

SCA 70

All rights are reserved. Reproduction in whole or in part is prohibited without the prior written consent of the copyright owner.

The information presented in this document does not form part of any quotation or contract, is believed to be accurate and reliable and may be changed without notice. No liability will be accepted by the publisher for any consequence of its use. Publication thereof does not convey nor imply any license under patent- or other industrial or intellectual property rights.

Printed in The Netherlands

753504/01/pp24

Date of release: 2000 Jul 20

Document order number: 9397 750 06914

Let's make things better.

Philips
Semiconductors



PHILIPS