

TOSHIBA CMOS Digital Integrated Circuit Silicon Monolithic

TC9314F-043

Single Chip Digital Tuning System for CD Radio Cassette

TC9314F-043 is a CMOS LSI designed for a PLL frequency synthesizer radio system corresponded to the requirement of the whole world.

Since TC9314F-043 can be used for TC9284BF the CD processor and receive remote control signal, a low cost compact CD radio system can be constructed.

Features

- Receiving band

Area	Jumper Setting			Band	Frequency Rang (Hz)	Step (Hz)	FREF (Hz)	IF	
	A1	A0	FM Step						
			MW Step						
USA	0	0	0	FM	87.5~107.9 M	200 k	25 k	+10.7 M	
			1		87.5~108.0 M	100 k			
			0	AM (Note 1)	530~1710 k	10 k	5 k	+450 k	
			1		531~1602 k	9 k	3 k		
General	0	1	0	FM	87.50~108.00 M	50 k	25 k	+10.7 M	
			1		87.5~108.0 M	100 k			
			0	MW/AM	522~1602 k	9 k	3 k	+450 k	
			1		530~1602 k	10 k	5 k		
			—	LW	146~281 k	1 k	1 k		
East Europe	1	0	0	FM	65.00~74.0 M	50 k	25 k	+10.7 M	
			1		87.50~108.00 M				50 k
					87.50~108.00 M				100 k
			0	MW/AM	531~1602 k	9 k	3 k	+450 k	
			1		530~1610 k	10 k	5 k		
			—	LW	146~281 k	1 k	1 k		
Japan	1	1	— (Note 2)	FM	76.0~90.0 M	100 k	25 k	-10.7 M	
			—	MW/AM	522~1629 M	9 k	3 k	+450	
			— (Note 3)	TV	1~12 ch	1 ch	25 k	-10.7 M	

Note 1: AM mark is indicated, even if band is MW with SW band in USA area.

Note 2: In case that there is not TV band, FM band extends (76.0-90.0 MHz + TV 1~3 ch).

Note 3: If TV band is selected, prescaler (TD7104P) is need.

There are SW bands with bands as shown above by setting of SW₀, SW₁ Jumper.

	Jumper Setting			Band	Frequency Rang (Hz)	Step (Hz)	FREF (Hz)	IF	Note
	SW1	SW0	FM Step						
			MW Step						
	0	0	—	no SW					
	0	1	—	SW _A	3.8~12.5 M	5k	5 k	+450 k	
	1	0	—	SW _B	5.95~15.6 M				
	1	1	—	SW ₁	2.3~7.3 M				
			—	SW ₂	9.5~26.1 M				

Note 4: Only SW mark is indicated for SW_A or SW_B.

Note 5: If jumper setting is SW₁, SW₂ when there is LW/TV band, SW₁, SW₂ bands are no set. (Maximum 4 band)

- Tuning functions and preset memory
 - manual up/down tuning
 - seek up/down tuning
- Preset memory
 - Fixed

FM/AM	20/20	stations
FM/MW/LW or TV	20/10/10	stations
FM/MW/SW-A or B	20/10/10	stations
FM/MW/LW or TV/SW-A or B	20/10/5/5	stations
FM/MW/SW ₁ /SW ₂	20/10/5/5	stations
 - Random

total	30	stations
-------	----	----------
- Clock functions
 - 12H/24H clock
 - TIMER on/off
 - SLEEP
- CD functions
 - random play
 - intro play
 - repeat play or track repeat play
 - memory play (max 20 preset)
- CD FF/REW
 - synchro rec mode
 - tray open/close control
 - indication of CD remain time
 - music calendar display
- Remote control functions
 - volume up / down control
 - direct selecting of preset memory and track number
- Other functions
 - preset equalizer control
 - function change (CD/TUNER/TAPE/AUX)
 - indication of STEREO mark
 - power on/off key
 - mute on/off control

Block Diagram

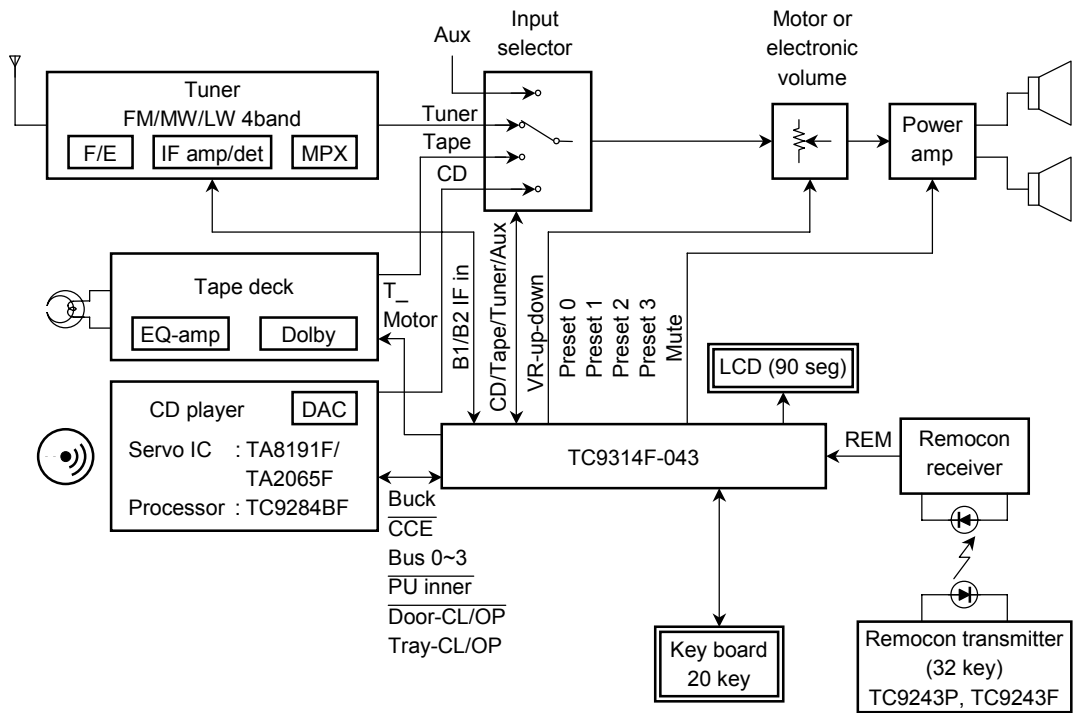

Layout

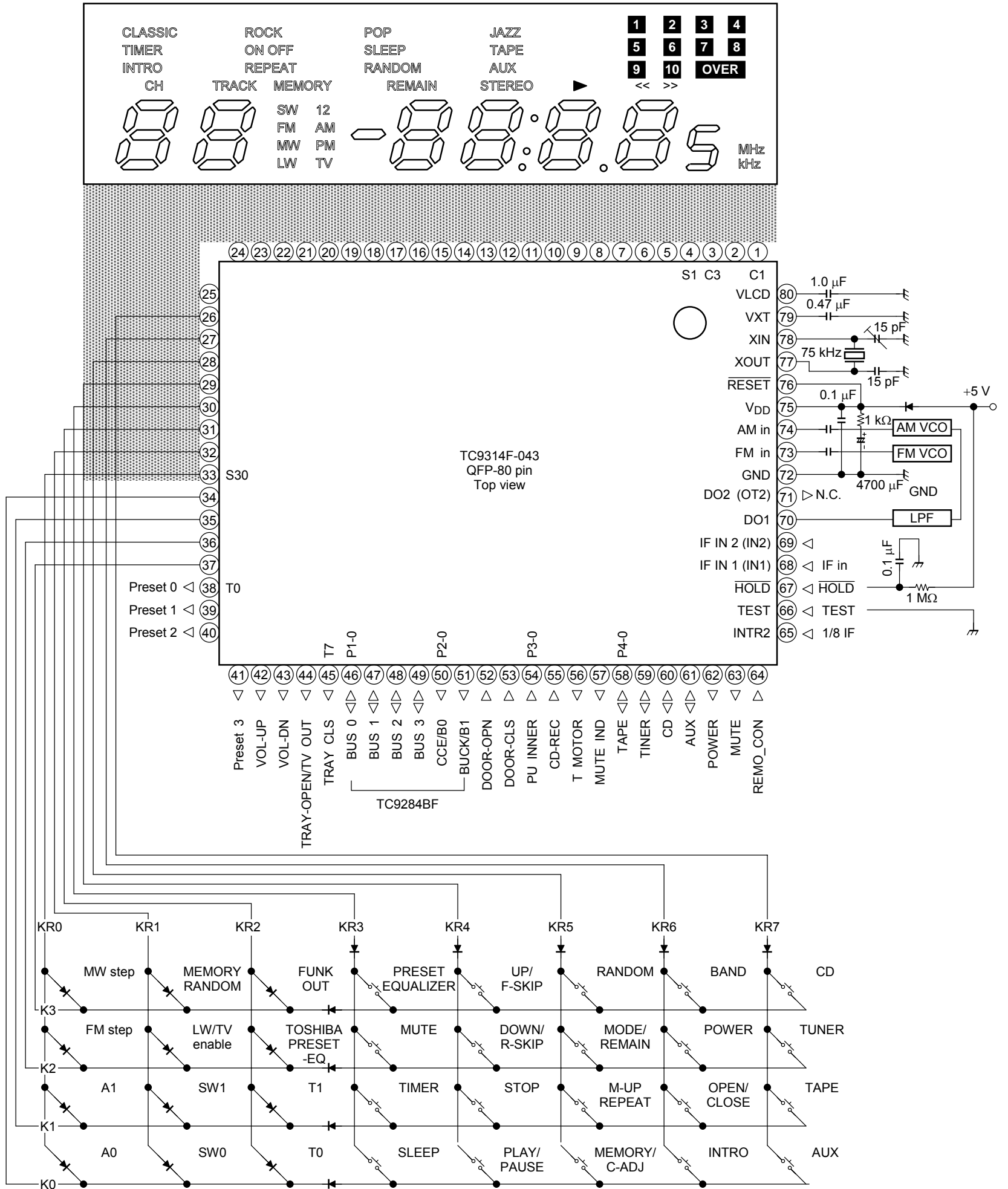

RESTRICTIONS ON PRODUCT USE

000707EBA

- TOSHIBA is continually working to improve the quality and reliability of its products. Nevertheless, semiconductor devices in general can malfunction or fail due to their inherent electrical sensitivity and vulnerability to physical stress. It is the responsibility of the buyer, when utilizing TOSHIBA products, to comply with the standards of safety in making a safe design for the entire system, and to avoid situations in which a malfunction or failure of such TOSHIBA products could cause loss of human life, bodily injury or damage to property.
In developing your designs, please ensure that TOSHIBA products are used within specified operating ranges as set forth in the most recent TOSHIBA products specifications. Also, please keep in mind the precautions and conditions set forth in the "Handling Guide for Semiconductor Devices," or "TOSHIBA Semiconductor Reliability Handbook" etc..
- The TOSHIBA products listed in this document are intended for usage in general electronics applications (computer, personal equipment, office equipment, measuring equipment, industrial robotics, domestic appliances, etc.). These TOSHIBA products are neither intended nor warranted for usage in equipment that requires extraordinarily high quality and/or reliability or a malfunction or failure of which may cause loss of human life or bodily injury ("Unintended Usage"). Unintended Usage include atomic energy control instruments, airplane or spaceship instruments, transportation instruments, traffic signal instruments, combustion control instruments, medical instruments, all types of safety devices, etc.. Unintended Usage of TOSHIBA products listed in this document shall be made at the customer's own risk.
- The products described in this document are subject to the foreign exchange and foreign trade laws.
- The information contained herein is presented only as a guide for the applications of our products. No responsibility is assumed by TOSHIBA CORPORATION for any infringements of intellectual property or other rights of the third parties which may result from its use. No license is granted by implication or otherwise under any intellectual property or other rights of TOSHIBA CORPORATION or others.
- The information contained herein is subject to change without notice.