

**TOSHIBA**

**Low Power CMOS ASIC  
0.3 $\mu$ m 3V/2V**

**TC222C Series Cell-Based IC**

**PRODUCT GUIDE**

# Overview

Toshiba's TC222C cell-based ASIC series provides silicon solutions to meet your design goals for high-performance and low-power systems. Fabricated on an advanced 0.3-micron double/triple metal CMOS process, the TC222C Series offers a choice of many different array sizes ranging from 59,000 to 2,077,000 usable gates. The TC222C Series is optimized for low 2.0V operation with dual 2.0/3.0V I/O options. The special cell architecture led to an extremely low power dissipation rating of 0.09  $\mu$  W/MHz/gate (with a fanout of 1). For a wide variety of applications, three or more variations of macrocells are available allowing the optimum tuning of performance and power. The placement-and-routing run can be power-driven to ensure that the result is the lowest power implementation that meets timing constraints. All these

features help to substantially reduce your chip's power while maximizing the critical path speed.

## Power Comparison

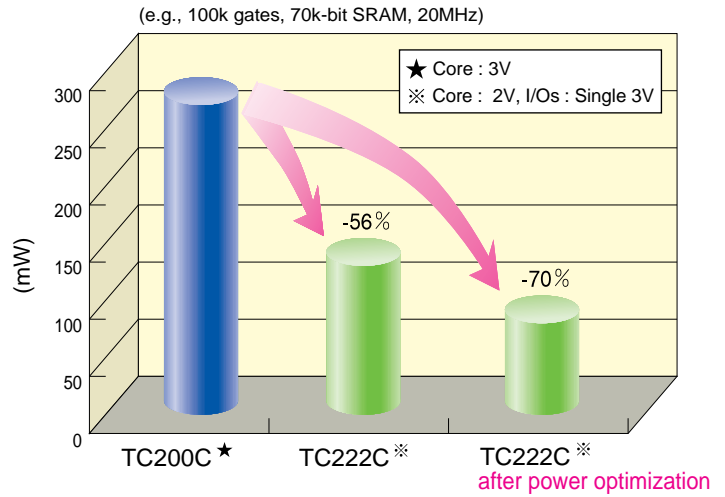

## Product Specifications

Process Technology	0.3 $\mu$ m HC <sup>2</sup> MOS Si-gate double-/triple-layer metal	
Gate Delay	2-input NAND, High drive, F/O = 1	0.10 ns
	2-input NAND, High drive, F/O = 2 + estimated wire load	0.21 ns
Power Consumption	2-input NAND, Low drive, F/O = 1*	0.09 $\mu$ W/MHz/gate
	2-input NAND, Low drive, F/O = 4*	0.18 $\mu$ W/MHz/gate
Power Supply	[Core] 2.0 V [I/O] 3.0 V / 2.0 V	
Recommended Operating Voltage Range	[Core] 2.0 V $\pm$ 0.2 V [I/O] 3.0 V $\pm$ 0.3 V / 2.0 V $\pm$ 0.2 V	

\* Loaded with low-power cell(s)

## Product Lines

Double-layer Metal				Triple-layer Metal				Maximum I/O Pads		
Ref. No	Part Number	Gird Complexity	Equivalent Gates	Ref. No	Part Number	Gird Complexity	Equivalent Gates	Wire Bonding	TCP/TBGA	PQFP[TAB]/TBGA
04	TC222C040	118,000	59,000	54	TC222C540	196,000	98,000	96	148	200
06	TC222C060	166,000	83,000	56	TC222C560	274,000	137,000	120	184	248
08	TC222C080	226,000	113,000	58	TC222C580	372,000	186,000	136	212	288
10	TC222C100	274,000	137,000	60	TC222C600	450,000	225,000	152	236	316
12	TC222C120	334,000	167,000	62	TC222C620	546,000	273,000	168	260	348
14	TC222C140	400,000	200,000	64	TC222C640	654,000	327,000	184	284	380
16	TC222C160	448,000	224,000	66	TC222C660	720,000	360,000	200	312	420
18	TC222C180	520,000	260,000	68	TC222C680	836,000	418,000	216	336	452
20	TC222C200	598,000	299,000	70	TC222C700	962,000	481,000	232	360	484
22	TC222C220	682,000	341,000	72	TC222C720	1,094,000	547,000	248	384	516
24	TC222C240	770,000	385,000	74	TC222C740	1,236,000	618,000	264	408	548
26	TC222C260	864,000	432,000	76	TC222C760	1,388,000	694,000	280	432	-
28	TC222C280	962,000	481,000	78	TC222C780	1,546,000	773,000	296	456	-
30	TC222C300	1,068,000	534,000	80	TC222C800	1,714,000	857,000	312	480	-
32	TC222C320	1,178,000	589,000	82	TC222C820	1,890,000	945,000	328	504	-
34	TC222C340	1,270,000	635,000	84	TC222C840	2,048,000	1,024,000	352	540	-
36	TC222C360	1,446,000	723,000	86	TC222C860	2,332,000	1,166,000	376	576	-
38	TC222C380	1,634,000	817,000	88	TC222C880	2,634,000	1,317,000	400	612	-
40	TC222C400	1,832,000	916,000	90	TC222C900	2,954,000	1,477,000	424	648	-
42	TC222C420	2,576,000	1,288,000	92	TC222C920	4,154,000	2,077,000	504	768	-

# System Application Example – Digital Camcorder –

Because customers buying ultraportable devices rank portability and long battery life at the top of their feature preferences, the TC222C Series are ideal for these products.

After the VHS-H and 8-mm Betacam models have long been the mainstay of consumer-use camcorders, digital video cameras (DVC) are now coming on the market. The DVC, expected to become the core equipment in the multimedia era, combines superior video quality with the ability to transmit video to a personal computer and to the Internet.

The high-density and low-power features of the TC222C Series were essential to successfully implement complex designs for the DVC. In the application example depicted below, the TC222C Series turned a five- or seven-piece chip set for the digital signal processing portion of digital camcorders into a two- or three-chip set. The TC222C chips additionally incorporated DRAM chips.

The rewards for designing with the TC222C Series are obvious. The new DVCs are light and easy to carry while the previous models were nearly as large as the early analog camcorders that were hoisted onto the shoulder. In addition, the TC222C implementation helped to dramatically extend battery life.

## Digital Signal Processing

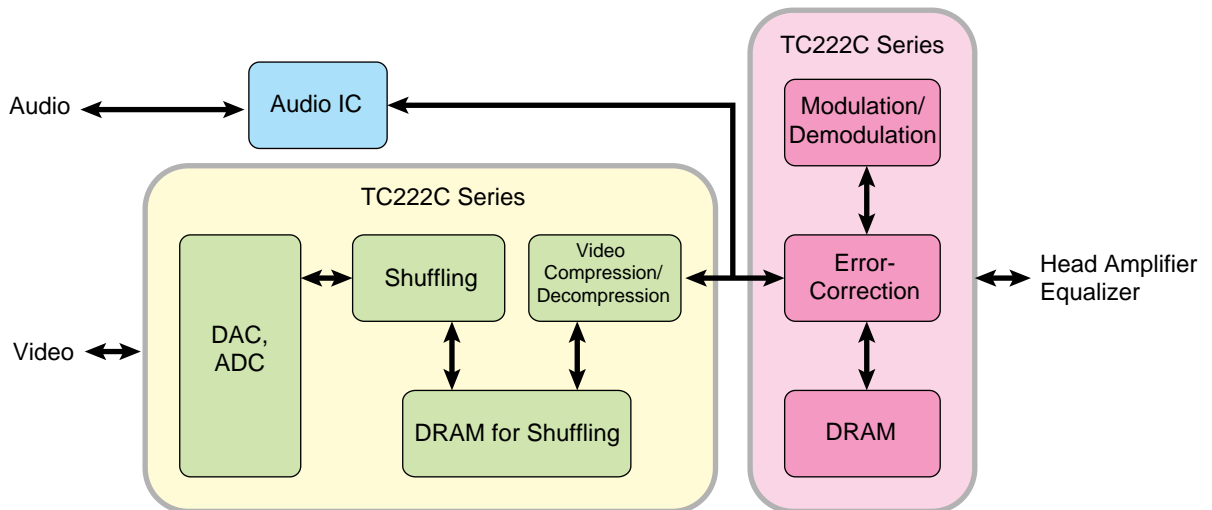

## Chip Layout

Integration allows high-performance specialized blocks for video compression, etc. to be consolidated onto the same chip. Operating at 2V, the TC222C Series reduces power dissipation in large, densely populated chips.

The TC222C operates with a 2V core and offers both 3V and 2V I/Os. The 2V core reduces the power consumption of your design, while the 3V and 2V I/O compatibility offers you flexibility with your system interface design.

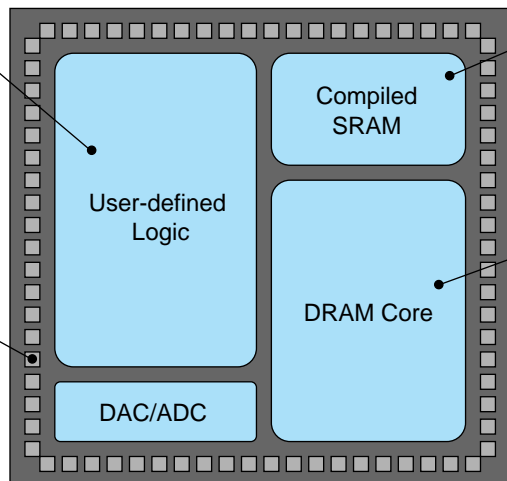

The megacell compiler software can generate a wide range of high-density SRAMs and ROMs in low-power models.

The embedded DRAM core is based on our world-leading 64-Mbit DRAM process technology.

**Toshiba America  
Electronic Components, Inc.**

**Headquarters-Irvine, CA**  
9775 Toledo Way, Irvine,  
CA 92718, U.S.A.  
Tel: (714)455-2000 Fax: (714)859-3963

**Altamonte Springs, FL(Orland)**  
600 S. North Lake Blvd., Suite 250,  
Altamonte Springs, FL 32701, U.S.A.  
Tel: (407)332-0966 Fax: (407)339-3777

**Deerfield, IL(Chicago)**  
One Pkwy., North, Suite 500, Deerfield,  
IL 60015-2547, U.S.A.  
Tel: (847)945-1500 Fax: (847)945-1044

**Denver, CO**  
8400 E. Prentice Englewood, CO 80111, U.S.A.  
Tel: (303)220-9848 Fax: (303)220-9856

**Edison, NJ**  
2035 Lincoln Hwy. Ste. #3000, Edison  
NJ 08817, U.S.A.  
Tel: (908)248-8070 Fax: (908)248-8030

**Irvine, CA**  
2 Venture Plaza, Suite 500, Irvine,  
CA 92718, U.S.A.  
Tel: (714)453-0224 Fax: (714)453-0125

**Microelectronics Center-Sunnyvale, CA**  
1220 Midas Way, Sunnyvale,  
CA 94088-3509, U.S.A.  
Tel: (408)739-0560 Fax: (408)746-0577

**Norcross, GA(Atlanta)**  
655 Engineering Dr. #160, Norcross,  
GA 30092, U.S.A.  
Tel: (404)368-0203 Fax: (404)368-0075

**Richardson, TX(Dallas)**  
777 East Campbell Rd., Suite 650, Richardson,  
TX 75081, U.S.A.  
Tel: (214)480-0470 Fax: (214)235-4114

**Wakefield, MA(Boston)**  
401 Edgewater Place, Suite #360, Wakefield,  
Essex, MA 01880-6229, U.S.A.  
Tel: (617)224-0074 Fax: (617)224-1095

**San Jose Engineering Center, CA**  
1060 Rincon Circle, San Jose,  
CA 95131, U.S.A.  
Tel: (408)456-8900 Fax: (408)456-8910

**Toshiba Electronics  
Europe GmbH**

**Düsseldorf Head Office**  
Hansaallee 181, D-40549 Düsseldorf  
Germany  
Tel: (0211)5296-0 Fax: (0211)5296-400

**Stuttgart Office**  
Buro Stuttgart, Eltinger Str.  
61, D-71229 Leonberg, Germany  
Tel: (07152)6045-0 Fax: (07152)6045-45

**München Office**  
Büro München Hofmannstrasse 52,  
D-81378, München, Germany  
Tel: (089)748595-0 Fax: (089)748595-42

**Berlin Office**  
Buro Berlin, Alt-Moabit 96B,  
D-10559, Berlin, Germany  
Tel: (030)-3999000 Fax: (030)-3999017

**Toshiba Electronics France SARL**  
Immeuble Robert Schumann 3 Rue de Rome,  
F-93561, Rosny-Sous-Bois, Cedex, France  
Tel: (1)48-12-48-12 Fax: (1)48-94-51-15

**Toshiba Electronics Italiana S.R.L.**  
Centro Direzionale Colleoni  
Palazzo Perseo Ingr. 2-Piano 6,  
Via Paracelso n.12,  
1-20041 Agrate Brianza Milan, Italy  
Tel: (039)68701 Fax:(039)6870205

**Toshiba Electronics España, S.A.**  
Parque Empresarial San Fernando Edificio Europa,  
1ª Planta, ES-28831 Madrid, Spain  
Tel: (91)660-6700 Fax:(91)660-6799

**Toshiba Electronics(UK) Limited**  
Riverside Way, Camberley Surrey,  
GU15 3YA, U.K.  
Tel: (01276)69-4600 Fax: (01276)69-4800

**Toshiba Electronics Scandinavia AB**  
Gustavslundsvägen 12, 2nd Floor  
S-161 15 Bromma, Sweden  
Tel: (08)704-0900 Fax: (08)80-8459

**Toshiba Electronics Asia  
(Singapore) Pte. Ltd.**

**Singapore Head Office**  
460 Alexandra Rd., #21-00 PSA Bldg.,  
Singapore 0511  
Tel: (278)5252 Fax: (271)5155, (270)6056

**Bangkok Office**  
135 Moo 5 Bangkadi Industrial Park, Tivanon Rd.,  
Bangkadi Amphur Muang Pathumthani 12000,  
Thailand  
Tel: (2)501-1635 Fax: (2)501-1638

**Toshiba Electronics Trading  
(Malaysia)Sdn. Bhd.**

**Kuala Lumpur Head Office**  
Suite W1203, Wisma Conspant, No.2,  
Jalan SS 16/4, Subang Jaya, 47500 Petaling Jaya,  
Selangor Darul Ehsan, Malaysia  
Tel: (3)731-6311 Fax: (3)731-6307

**Penang Office**  
Suite 13-1, 13th Floor, Menard Penang Garden,  
42-A, Jalan Sultan Ahmad Shah,  
100 50 Penang, Malaysia  
Tel: 4-226-8523 Fax: 4-226-8515

**Toshiba Electronics Asia, Ltd.**

**Hong Kong Head Office**  
Level 11, Top Glory Insurance Building,  
Grand Century Place,  
No.193, Prince Edward Road West,  
Mong Kok, Kowloon, Hong Kong  
Tel: 2375-6111 Fax: 2375-0969

**Seoul Branch**  
14/F, KEC B/D, 257-7 Yangjae-dong,  
Seocho-ku, Seoul, Korea  
Tel: (02)589-4334 Fax: (02)589-4302

**Seoul Branch, Gumi Office**  
6/F, Ssangyong Investment Securities B/D,  
56 Songjung-Dong, Gumi City  
Kyeongbuk, Korea  
Tel: (0645)456-7613-6 Fax: (0546)456-7617

**Shenzhen Office**  
Rm 3010-3012, Shun Hing Square,  
Di Wang Commercial Centre,  
333 Shennan Road East,  
Shenzhen, China, 518008  
Tel: (0755)246-1582 Fax: (0755)246-1581

**Shanghai Office**  
RM2612 26F, Rui Jin Bldg., 205 Mao Ming  
South Rd., Shanghai, China  
Tel: (021)64723077 Fax: (021)64727028

**Tsurong Xiamen Xiangyu Trading Co., Ltd.**  
8N, Xiamen Sez Bonded Goods Market Building,  
Xiamen, Fujian, China  
Tel: (0592)562-3798 Fax:(0592)562-3799

**Beijing Office**  
Rm 714, Beijing Fortune Building,  
No.5 Dong San Huan Bei-Lu, Chao Yang District,  
Beijing, China, 10004  
Tel:(010)6595-8795 Fax: (010)6591-9346

**Toshiba Electronics  
Taiwan Corporation**

**Taipei Head Office**  
17F, Union Enterprise Plaza Bldg. 109  
Min Sheng East Rd., Section 3, 0446 Taipei,  
Taiwan  
Tel: (02)514-9988 Fax: (02)514-7892

**Kaohsiung Office**  
16F-A, Chung-Cheng Bldg., Chung-Cheng 3Rd.,  
80027, Kaohsiung, Taiwan  
Tel: (07)222-0826 Fax: (07)223-0046

**Toshiba Display Devices  
(Thailand) Co., Ltd.**  
142 Moo 5, Bangkadi Industrial Park,  
Tivanon Rd., Pathumthani 12000, Thailand  
Tel: (2)501-1200 Fax: (2)501-1209

The information contained herein is subject to change without notice.

The information contained herein is presented only as a guide for the applications of our products. No responsibility is assumed by TOSHIBA for any infringements of patents or other rights of the third parties which may result from its use. No license is granted by implication or otherwise under any patent or patent rights of TOSHIBA or others.

TOSHIBA is continually working to improve the quality and the reliability of its products. Nevertheless, semiconductor devices in general can malfunction or fail due to their inherent electrical sensitivity and vulnerability to physical stress. It is the responsibility of the buyer, when utilizing TOSHIBA products, to observe standards of safety, and to avoid situations in which a malfunction or failure of a TOSHIBA product could cause loss of human life, bodily injury or damage to property. In developing your designs, please ensure that TOSHIBA products are used within specified operating ranges as set forth in the most recent products specifications. Also, please keep in mind the precautions and conditions set forth in the TOSHIBA Semiconductor Reliability Handbook.

The products described in this document are subject to foreign exchange and foreign trade control laws.

In Touch with Tomorrow  
**TOSHIBA**

**TOSHIBA CORPORATION**

**International Operations-Electronic Components**  
1-1, Shibaura 1-chome, Minato-ku, Tokyo, 105-01, Japan  
Tel:(03)3457-3495 Fax: (03)5444-9431