

374-453

13-INPUT NAND GATE

DESCRIPTION

The T74LS133 is a high speed 13-INPUT NAND GATE fabricated in silicon LOW POWER SCHOTTKY technology.

SCHEMATIC

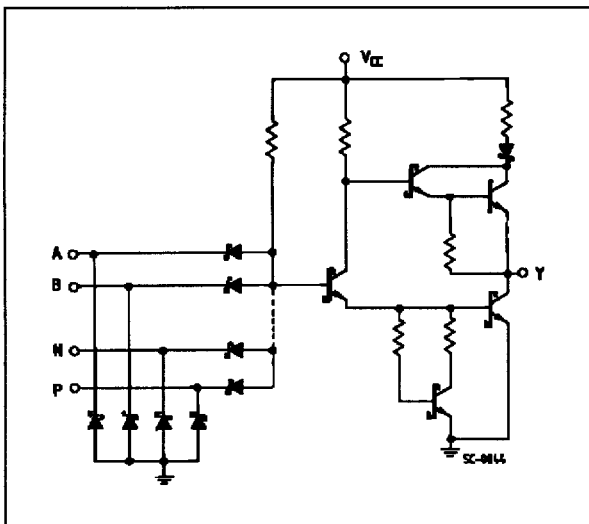

B1
(Plastic Package)

D1
(Ceramic Package)

M1
(Micro Package)

C1
(Plastic Chip Carrier)

ORDER CODES :

T74LS133 D1	T74LS133 C1
T74LS133 B1	T74LS133 M1

PIN CONNECTION (top view)

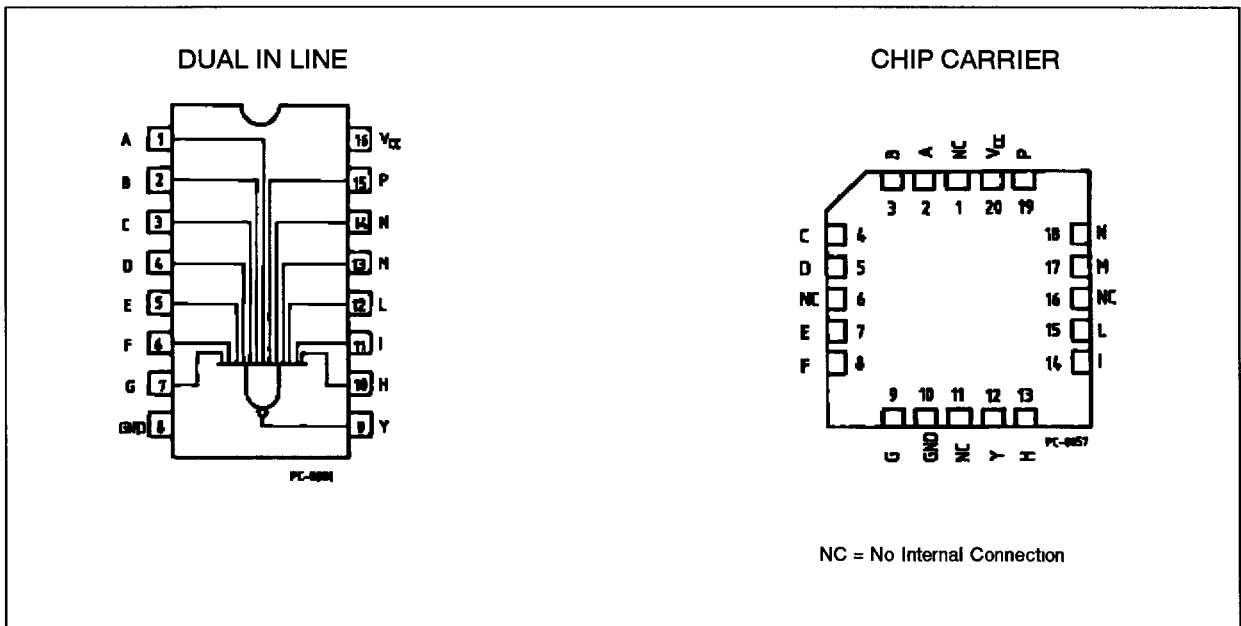

T74LS133

LOGIC DIAGRAM AND TRUTH TABLE

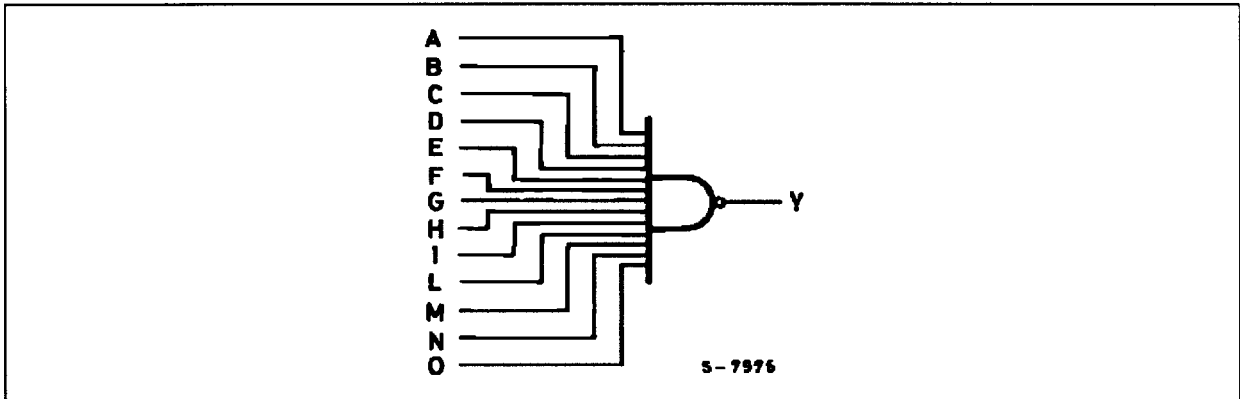

ABSOLUTE MAXIMUM RATINGS

Symbol	Parameter	Value	Unit
V_{CC}	Supply Voltage	- 0.5 to 7	V
V_I	Input Voltage, Applied to Input	- 0.5 to 15	V
V_O	Output Voltage, Applied to Output	- 0.5 to 10	V
I_I	Input Current, into Inputs	- 30 to 5	mA
I_O	Output Current, into Outputs	60	mA

Stresses in excess of those listed under "Absolute Maximum Ratings" may cause permanent damage to the device. This is a stress rating only and functional operation of the device at these or any other conditions in excess of those indicated in the operational sections of this specification is not implied. Exposure to absolute maximum rating conditions for extended periods may affect device reliability.

GUARANTEED OPERATING RANGE

Part Numbers	Supply Voltage			Temperature
	Min.	Typ.	Max.	
T74LS133XX	4.75 V	5.0 V	5.25 V	0 °C to + 70 °C

XX = package type.

DC CHARACTERISTICS OVER OPERATING TEMPERATURE RANGE

Symbol	Parameter	Limits			Test Condition (note 1)	Unit
		Min.	Typ. (*)	Max.		
V _{IH}	Input HIGH Voltage	2.0			Guaranteed Input HIGH Voltage	V
V _{IL}	Input LOW Voltage			0.8	Guaranteed Input LOW Voltage	V
V _{CD}	Input Clamp Diode Voltage		- 0.65	- 1.5	V _{CC} = MIN, I _{IN} = -18 mA	V
V _{OH}	Output HIGH Voltage	2.7	3.4		V _{CC} = MIN, I _{OH} = - 400 μ A V _{IN} = V _{IL}	μ A
V _{OL}	Output LOW Voltage		0.25	0.4	I _{OL} = 4.0 mA	V _{CC} = MIN
			0.35	0.5	I _{OL} = 8.0 mA	V _{IN} = 2.0 V
I _{IH}	Input HIGH Current		1.0	20	V _{CC} = MAX, V _{IN} = 2.7 V	μ A
				0.1	V _{CC} = MAX, V _{IN} = 7.0 V	mA
I _{IL}	Input LOW Current			- 0.4	V _{CC} = MAX, V _{IN} = 0.4 V	mA
I _{OS}	Output Short Circuit Current (note 2)	- 20		- 100	V _{CC} = MAX, V _{OUT} = 0 V	mA
I _{CCH}	Supply Current HIGH		0.35	0.5	V _{CC} = MAX, V _{IN} = 0 V	mA
I _{CCL}	Supply Current LOW		0.6	1.1	V _{CC} = MAX, Inputs Open	mA

Notes : 1 For conditions shown as MIN or MAX, use the appropriate value specified under guaranteed operating ranges
 2 Not more than one output should be shorted at a time
 (*) Typical values are at V_{CC} = 5.0 V, T_A = 25 °C

AC CHARACTERISTICS: T_A = 25°C (for AC test circuits and waveforms see databook introduction)

Symbol	Parameter	Limits			Test Conditions	Unit
		Min.	Typ.	Max.		
t _{PLH}	Turn Off Delay, Input to Output		10	15	V _{CC} = 5.0 V C _L = 15 pF	ns
t _{PHL}	Turn On Delay, Input to Output		25	38		ns

Plastic DIP16 (0.25) MECHANICAL DATA

DIM.	mm			inch		
	MIN.	TYP.	MAX.	MIN.	TYP.	MAX.
a1	0.51			0.020		
B	0.77		1.65	0.030		0.065
b		0.5			0.020	
b1		0.25			0.010	
D			20			0.787
E		8.5			0.335	
e		2.54			0.100	
e3		17.78			0.700	
F			7.1			0.280
I			5.1			0.201
L		3.3			0.130	
Z			1.27			0.050

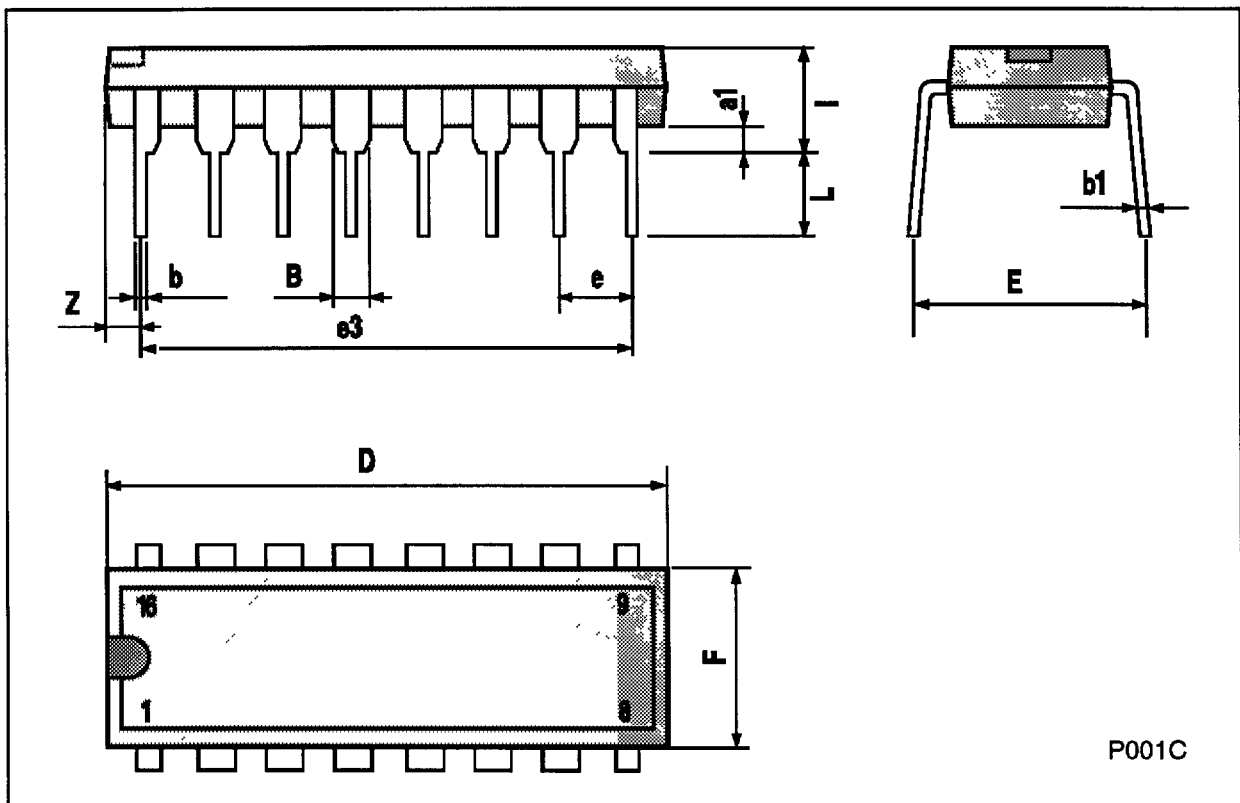

Ceramic DIP16/1 MECHANICAL DATA

DIM.	mm			inch		
	MIN.	TYP.	MAX.	MIN.	TYP.	MAX.
A			20			0.787
B			7			0.276
D		3.3			0.130	
E	0.38			0.015		
e3		17.78			0.700	
F	2.29		2.79	0.090		0.110
G	0.4		0.55	0.016		0.022
H	1.17		1.52	0.046		0.060
L	0.22		0.31	0.009		0.012
M	0.51		1.27	0.020		0.050
N			10.3			0.406
P	7.8		8.05	0.307		0.317
Q			5.08			0.200

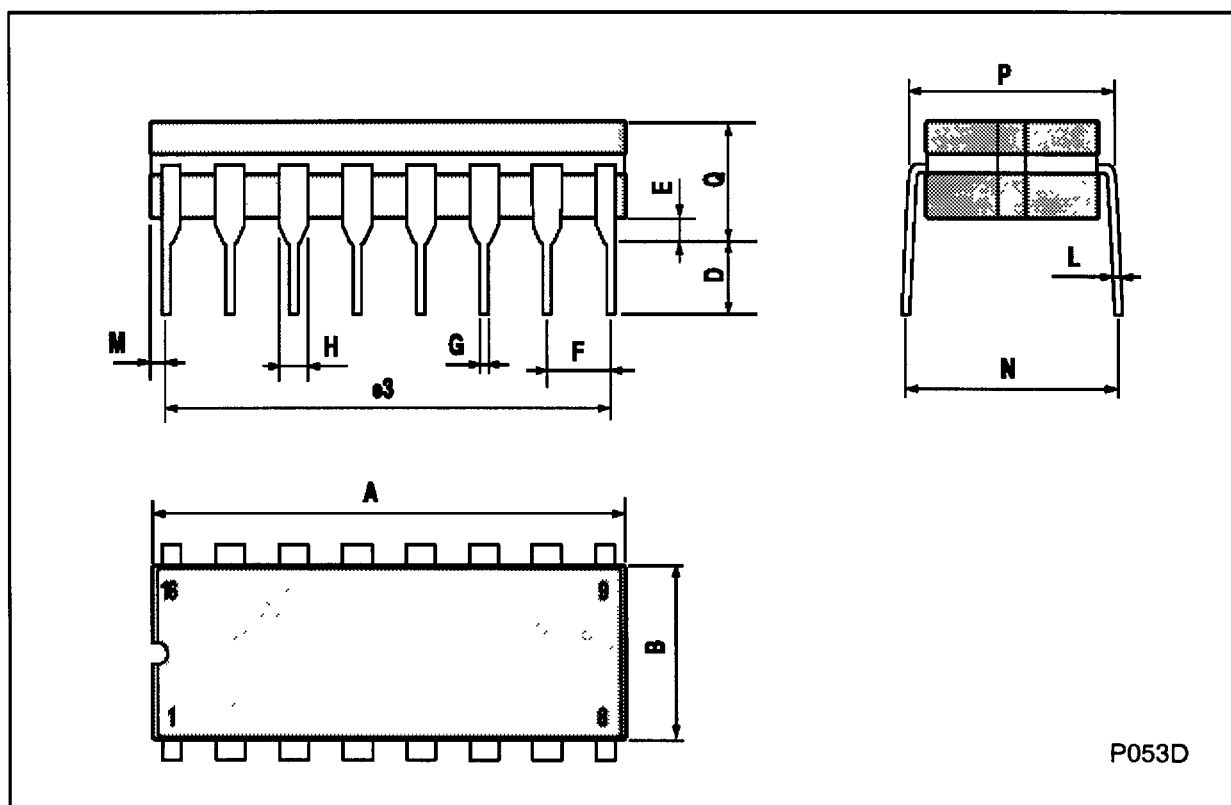

SO16 (Narrow) MECHANICAL DATA

DIM.	mm			inch		
	MIN.	TYP.	MAX.	MIN.	TYP.	MAX.
A			1.75			0.068
a1	0.1		0.2	0.004		0.007
a2			1.65			0.064
b	0.35		0.46	0.013		0.018
b1	0.19		0.25	0.007		0.010
C		0.5			0.019	
c1	45° (typ.)					
D	9.8		10	0.385		0.393
E	5.8		6.2	0.228		0.244
e		1.27			0.050	
e3		8.89			0.350	
F	3.8		4.0	0.149		0.157
G	4.6		5.3	0.181		0.208
L	0.5		1.27	0.019		0.050
M			0.62			0.024
S	8° (max.)					

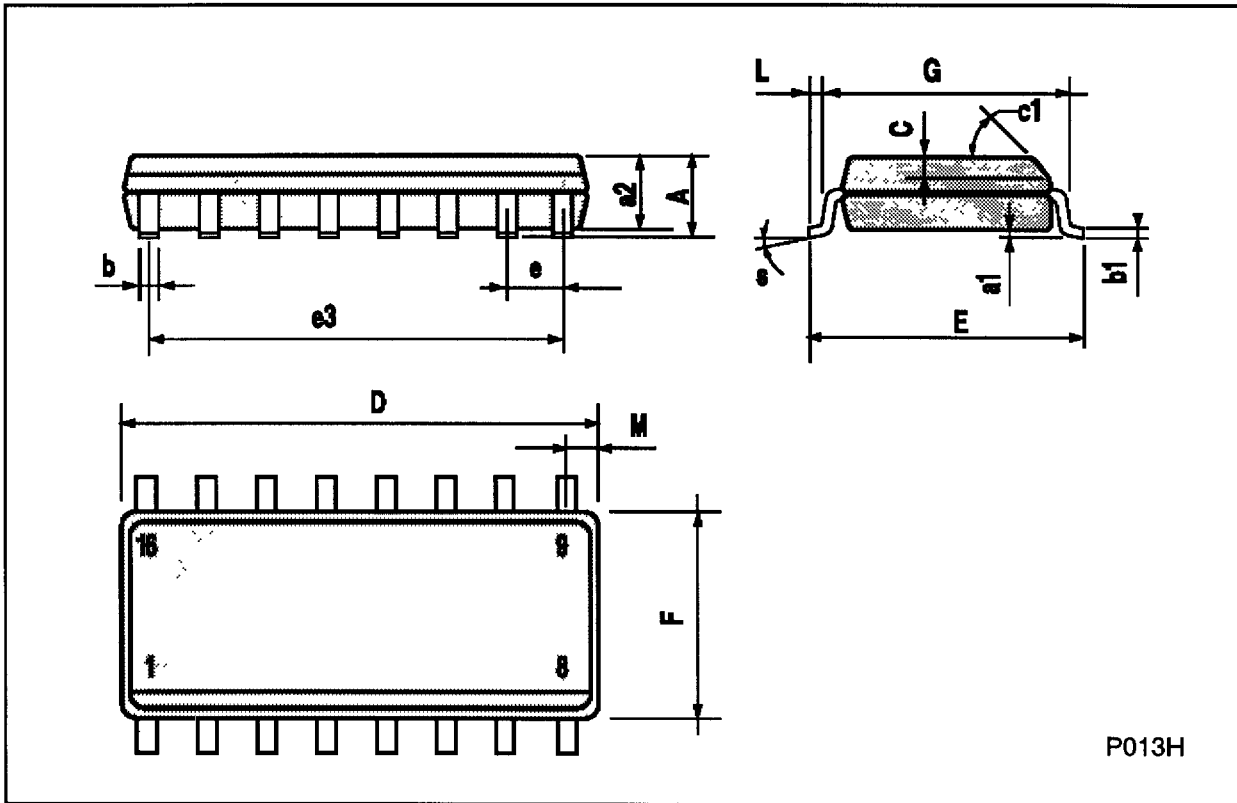

PLCC20 MECHANICAL DATA

DIM.	mm			Inch		
	MIN.	TYP.	MAX.	MIN.	TYP.	MAX.
A	9.78		10.03	0.385		0.395
B	8.89		9.04	0.350		0.356
D	4.2		4.57	0.165		0.180
d1		2.54			0.100	
d2		0.56			0.022	
E	7.37		8.38	0.290		0.330
e		1.27			0.050	
e3		5.08			0.200	
F		0.38			0.015	
G			0.101			0.004
M		1.27			0.050	
M1		1.14			0.045	

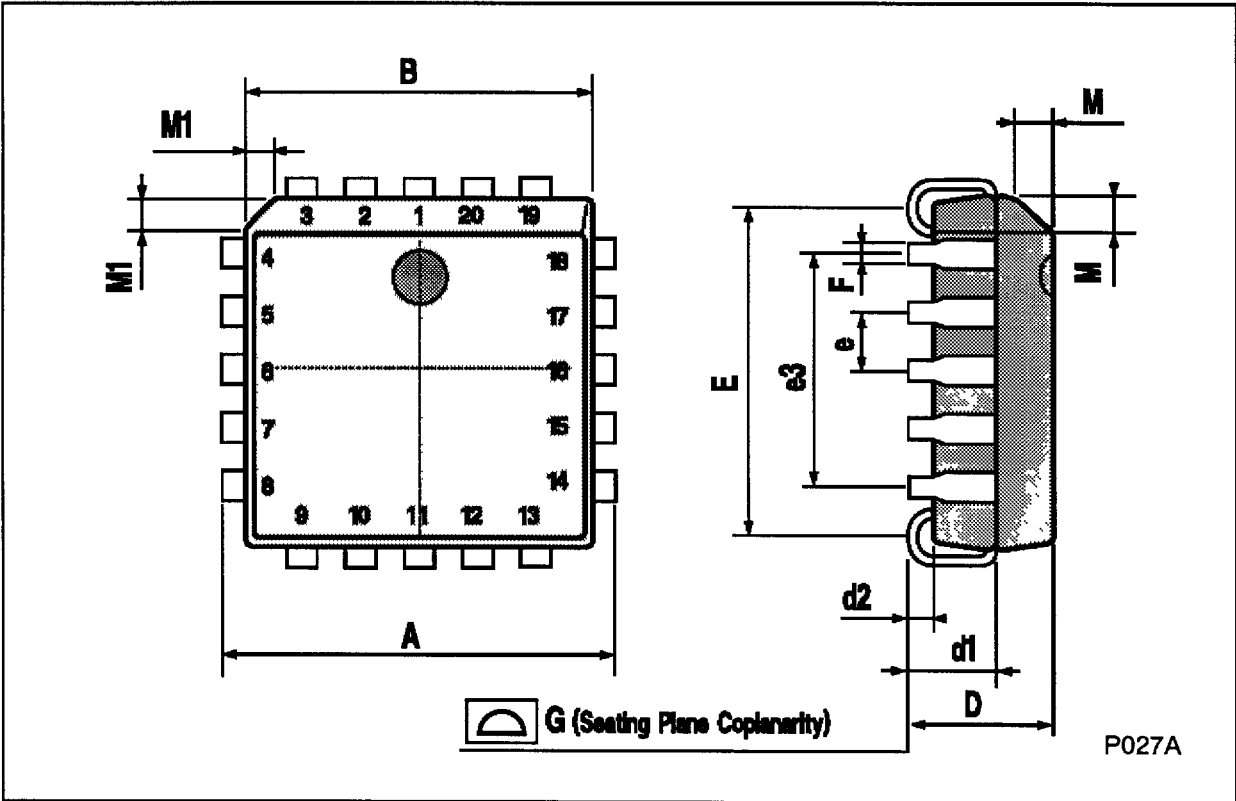

Information furnished is believed to be accurate and reliable. However, SGS-THOMSON Microelectronics assumes no responsibility for the consequences of use of such information nor for any infringement of patents or other rights of third parties which may result from its use. No license is granted by implication or otherwise under any patent or patent rights of SGS-THOMSON Microelectronics. Specifications mentioned in this publication are subject to change without notice. This publication supersedes and replaces all information previously supplied. SGS-THOMSON Microelectronics products are not authorized for use as critical components in life support devices or systems without express written approval of SGS-THOMSON Microelectronics.

© 1994 SGS-THOMSON Microelectronics - All Rights Reserved

SGS-THOMSON Microelectronics GROUP OF COMPANIES
Australia - Brazil - France - Germany - Hong Kong - Italy - Japan - Korea - Malaysia - Malta - Morocco - The Netherlands -
Singapore - Spain - Sweden - Switzerland - Taiwan - Thailand - United Kingdom - U S A