

8-BIT ODD/EVEN PARITY GENERATOR/CHECKER

S54180 N74180

S54180-A,F,W • N74180-A,F

DIGITAL 54/74 TTL SERIES

DESCRIPTION

The 54/74180 8-Bit Odd/Even Parity Generator/Checker is a TTL monolithic array featuring gating logic arranged to generate or check odd or even parity.

LOGIC DIAGRAM

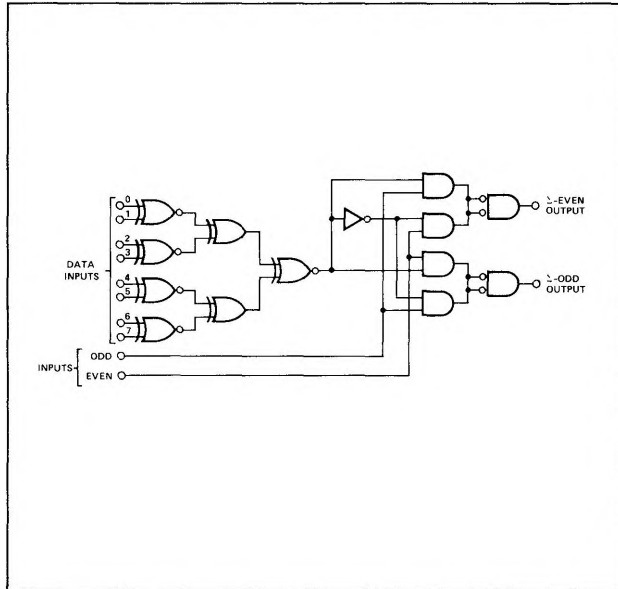

PIN CONFIGURATIONS

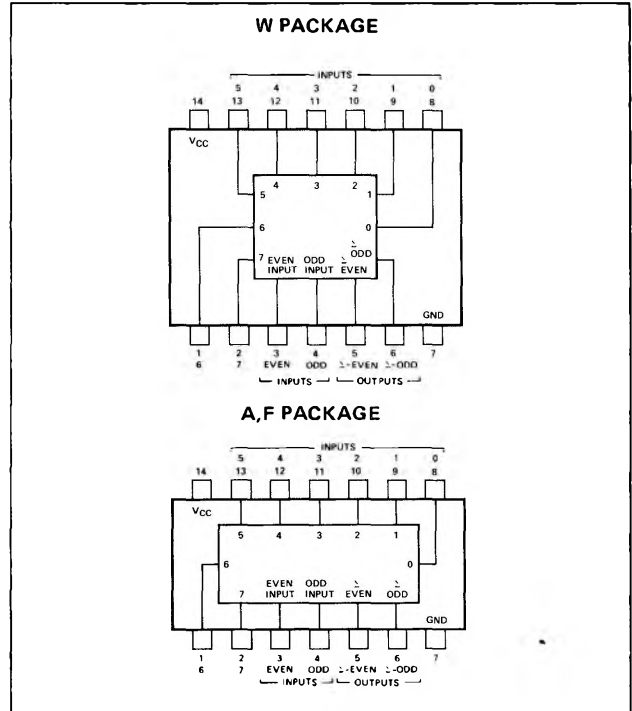

TRUTH TABLE

	INPUTS		OUTPUTS		
	Σ OF 1's AT 0 THRU 7	EVEN	ODD	Σ EVEN	Σ ODD
EVEN		1	0	1	0
ODD		1	0	0	1
EVEN		0	1	0	1
ODD		0	1	1	0
X		1	1	0	0
X		0	0	1	1

X = irrelevant

RECOMMENDED OPERATING CONDITIONS

	MIN	NOM	MAX	UNIT
Supply Voltage V_{CC} (See Note 1): S54180	4.5	5	5.5	V
N74180	4.75	5	5.25	V
Normalized Fan-Out from each Output, N: Logical 0			10	V
Logical 1			20	V

NOTE: 1. These voltage values are with respect to network ground terminal.

SIGNETICS DIGITAL 54/74 TTL SERIES - S54180 • N74180

ELECTRICAL CHARACTERISTICS (over recommended operating free-air temperature range unless otherwise noted)

PARAMETER		TEST CONDITIONS *	MIN	TYP **	MAX	UNIT
$V_{in(1)}$	Input voltage required to ensure logical 1 at any input terminal	$V_{CC} = \text{MIN}$	2			V
$V_{in(0)}$	Input voltage required to ensure logical 0 at any input terminal	$V_{CC} = \text{MIN}$			0.8	V
$V_{out(1)}$	Logical 1 output voltage	$V_{CC} = \text{MIN}, V_{in(1)} = 2V,$ $V_{in(0)} = 0.8V, I_{load} = -800\mu A$	2.4			V
$V_{out(0)}$	Logical 0 output voltage	$V_{CC} = \text{MIN}, V_{in(1)} = 2V$ $V_{in(0)} = 0.8V, I_{sink} = 16mA$			0.4	V
$I_{in(1)}$	Logical 1 level input current at each data input	$V_{CC} = \text{MAX}, V_{in} = 2.4V$			40	μA
		$V_{CC} = \text{MAX}, V_{in} = 5.5V$			1	mA
$I_{in(0)}$	Logical 0 level input current at each data input	$V_{CC} = \text{MAX}, V_{in} = 0.4V$			-1.6	mA
$I_{in(1)}$	Logical 1 level input current at even or odd input	$V_{CC} = \text{MAX}, V_{in} = 2.4V$			80	μA
		$V_{CC} = \text{MAX}, V_{in} = 5.5V$			1	mA
$I_{in(0)}$	Logical 0 level input current at even or odd input	$V_{CC} = \text{MAX}, V_{in} = 0.4V$			-3.2	mA
I_{OS}	Short-circuit output current†	$V_{CC} = \text{MAX}$		-20	-55	mA
			S54180 N74180	-18	-55	mA
I_{CC}	Supply current	$V_{CC} = \text{MAX}$		34	49	mA
			S54180 N74180	34	56	mA

SWITCHING CHARACTERISTICS, $V_{CC} = 5V, T_A = 25^\circ C, N = 10$

PARAMETER	FROM (INPUT)	TO (OUTPUT)	TEST CONDITIONS		MIN	TYP	MAX	UNIT
t_{pd1}	Data	Σ Even	$C_L = 15pF,$	$R_L = 400\Omega$		40	60	ns
t_{pd0}	Data	Σ Even	$C_L = 15pF,$	$R_L = 400\Omega$		25	38	ns
t_{pd1}	Data	Σ Odd	$C_L = 15pF,$	$R_L = 400\Omega$		32	48	ns
t_{pd0}	Data	Σ Odd	$C_L = 15pF,$	$R_L = 400\Omega$		45	68	ns
t_{pd1}	Data	Σ Even	$C_L = 15pF,$	$R_L = 400\Omega$		32	48	ns
t_{pd0}	Data	Σ Even	$C_L = 15pF,$	$R_L = 400\Omega$		45	68	ns
t_{pd1}	Data	Σ Odd	$C_L = 15pF,$	$R_L = 400\Omega$		40	60	ns
t_{pd0}	Data	Σ Odd	$C_L = 15pF,$	$R_L = 400\Omega$		25	38	ns
t_{pd1}	Even or Odd	Σ Even or Σ Odd	$C_L = 15pF,$	$R_L = 400\Omega$		13	20	ns
t_{pd0}	Even or Odd	Σ Even or Σ Odd	$C_L = 15pF,$	$R_L = 400\Omega$		7	10	ns

* For conditions shown as MIN or MAX, use the appropriate value specified under recommended operating conditions of the applicable device type.

** All typical values are at $V_{CC} = 5V, T_A = 25^\circ C$.

† Not more than one output should be shorted at a time.