

### 3-INPUT VIDEO SUPER IMPOSER

■ GENERAL DESCRIPTION

The NJM2248 is 3-input video switch for video and audio signal. Two input terminals have sink-chip clamp function and so it is applied to fixed DC level of video signal. The other input terminal is transistor base input for luminant signal and so luminant level may be easily fixed by outer circuit. Its operating supply voltage range is 4.75 to 13V and bandwidth is 10MHz. Cross-talk is 70dB (at 4.43MHz).

■ FEATURES

- Operating Voltage (+4.75V ~ +13V)
- 3 Input-1 Output
- Internal Clamp Function ( $V_{IN1}$ ,  $V_{IN2}$ )
- Internal Luminance Signal Control Function ( $V_{IN3}$ )
- Cross-talk 70dB(at 4.43MHz)
- Wide Frequency Range
- Package Outline DIP8, DMP8, SIP8, (SSOP8)
- Bipolar Technology

■ APPLICATION

- VCR, Video Camera, AV-TV, Video Disc Player

■ PIN CONFIGURATION

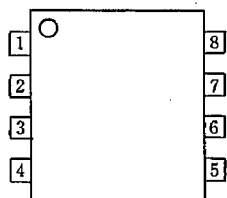

NJM2248D  
NJM2248M  
NJM2248V

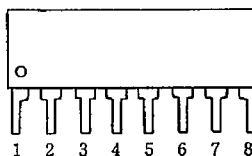

NJM2248L

PIN FUNCTION

1.  $V_{IN1}$
2. SW 1
3.  $V_{IN2}$
4. SW 2
5.  $V_{IN3}$
6.  $V^+$
7.  $V_{OUT}$
8. GND

■ BLOCK DIAGRAM

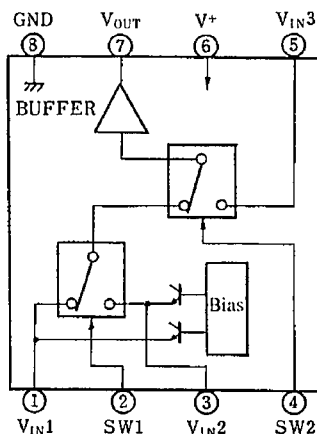

■ INPUT CONTROL SIGNAL-OUTPUT SIGNAL

SW 1	SW 2	OUTPUT SIGNAL
L	L	$V_{IN1}$
H	L	$V_{IN2}$
L/H	H	$V_{IN3}$

5

## ■ ABSOLUTE MAXIMUM RATINGS

( $T_a=25^\circ\text{C}$ )

PARAMETER	SYMBOL	RATINGS	UNIT
Supply Voltage	$V^+$	15	V
Power Dissipation	$P_d$	(DIP8) 500	mW
		(DMP8) 300	mW
		(SSOP8) 250	mW
		(SIP8) 800	mW
Operating Temperature Range	$T_{opr}$	$-20 \sim +75$	$^\circ\text{C}$
Storage Temperature Range	$T_{stg}$	$-40 \sim +125$	$^\circ\text{C}$

## ■ ELECTRICAL CHARACTERISTICS

( $V^+=5\text{V}$ ,  $T_a=25^\circ\text{C}$ )

PARAMETERS	SYMBOLS	TEST CONDITIONS	MIN.	TYP.	MAX.	UNIT.
Recommended Supply Voltage	$V^+$		4.75	—	13.0	V
Operating Current	$I_{CC}$	$S1=S2=S3=S4=S5=1$	—	10.5	14.0	mA
Voltage Gain	$G_v$	$V_1=2.5\text{V}_{p-p}, 100\text{kHz}$ , $V_O/V_1$	-0.5	—	+0.5	dB
Frequency Characteristics	$G_f$	$V_1=2.0\text{V}_{p-p}$ , $V_O(10\text{MHz})/V_O(100\text{kHz})$	-1.0	0	+1.0	dB
Differential Gain	DG	$V_1=2\text{V}_{p-p}$ , Staircase Signal	—	0	—	%
Differential Phase	DP	$V_1=2\text{V}_{p-p}$ , Staircase Signal	—	0	—	deg
Cross-talk	CT	$V_1=2.0\text{V}_{p-p}$ , 4.43MHz, $V_O/V_1$ (note 1)	—	-70	—	dB
Switch Change Voltage	$V_{CH}$	All inside SW: ON	2.4	—	—	V
	$V_{CL}$	All inside SW: OFF	—	—	0.8	V
Output Impedance	$R_O$		—	10	—	$\Omega$

(Note 1): Tested on all combination except three below.

a)  $S1=2, S4=S5=1$  b)  $S2=2, S4=2, S5=1$  c)  $S3=2, S5=2$

(Note 2): Unless specified, tested with  $V_{BIAS}=3\text{V}$ .

(Note 3): If it is not shown about switch condition, it is tested on three condition below.

a)  $S1=2, S2=S3=S4=S5=1$  b)  $S1=1, S2=2, S3=1, S4=2, S5=1$  c)  $S1=S2=1, S3=2, S4=1$  or  $2, S5=2$

(Note 4): Clamp voltage of  $V_{in1}$  and  $V_{in2}$  is about 2/5 of supply voltage (about 2.0V if  $V^+=5\text{V}$ ).

## ■ SPECIAL CARES TO BE TAKEN WHEN APPLICATION

This IC requires  $1\text{M}\Omega$  resistance between INPUT and GND pin for clamp type input since the minute current causes an unstable pin voltage.

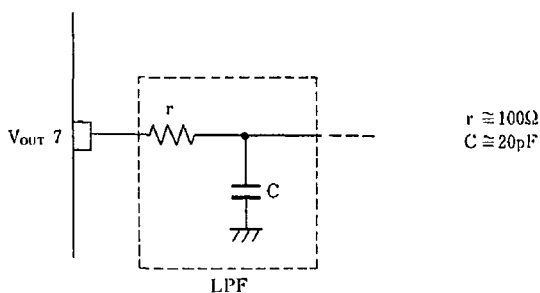

## ■ TEST CIRCUIT

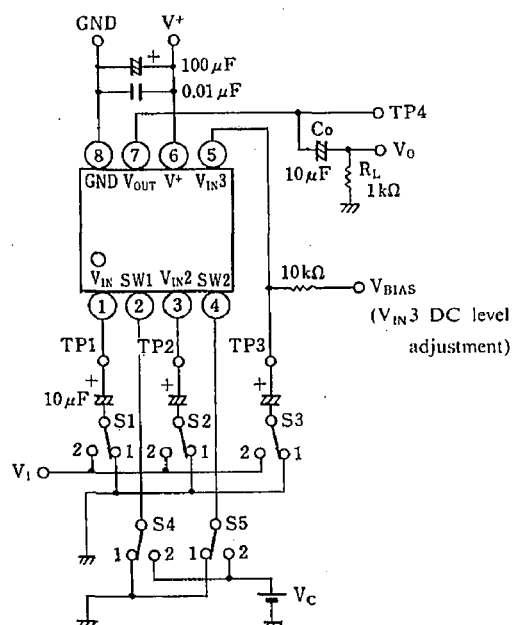

## ■ TERMINAL FUNCTION

PIN NO.	PIN SYMBOL	EQUIVALENT CIRCUIT	PIN NO.	PIN SYMBOL	EQUIVALENT CIRCUIT
1	V <sub>IN1</sub>		5	V <sub>IN3</sub>	
2	SW 1		6	V+	
3	V <sub>IN2</sub>		7	V <sub>OUT</sub>	
4	SW 2		8	GND	

## ■APPLICATION

This IC requires  $1\text{M}\Omega$  resistance between INPUT and GND pin for clamp type input since the minute current causes an unstable pin voltage.

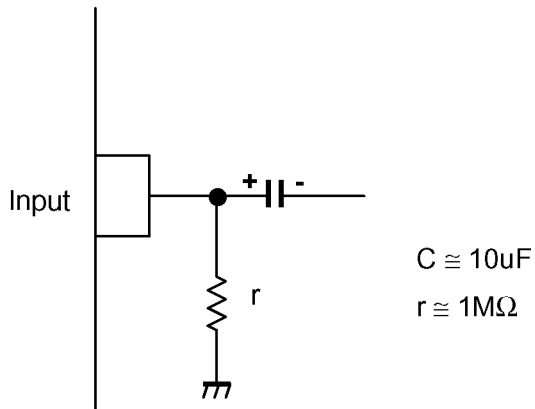

This IC requires  $0.1\mu\text{F}$  capacitor between INPUT and GND,  $1\text{M}\Omega$  resistance between INPUT and GND for clamp type input at mute mode.

