



# MAXIM

## 3V, Ultra-Low-Power Quadrature Modulator

MAX2452

### General Description

The monolithic MAX2452 is a quadrature modulator with supporting oscillator and divide-by-8 prescaler. It operates from a single +3V supply and draws only 4.1mA. The modulator accepts differential I and Q baseband signals with amplitudes up to 1.35Vp-p and bandwidths up to 15MHz. It produces a differential output up to 80MHz.

Pulling the CMOS-compatible ENABLE pin low reduces the supply current to 2µA. To minimize spurious feedback, the MAX2452's internal oscillator is set at twice the IF via external tuning components. The oscillator and associated phase shifters produce differential signals exhibiting low amplitude and phase imbalance, yielding 42dB sideband rejection. The MAX2452 comes in a 16-pin narrow SO package.

### Applications

- Digital Cordless Phones
- GSM and North American Cellular Phones
- Wireless LANs
- Digital Communications
- Two-Way Pagers

### Pin Configuration

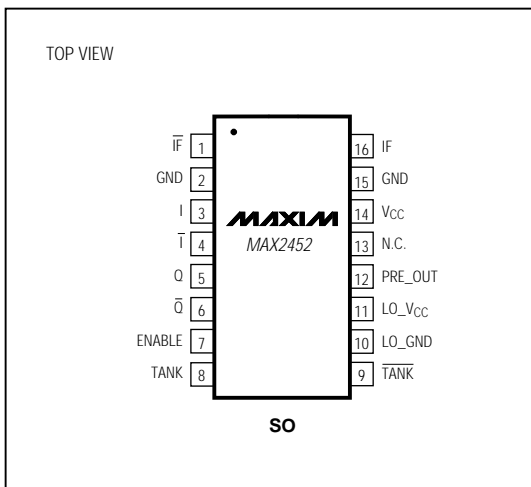

### Features

- ♦ IF Output Frequency up to 80MHz
- ♦ Input Bandwidth up to 15MHz
- ♦ On-Chip Oscillator with External Tuning Circuit
- ♦ On-Chip Divide-by-8 Prescaler
- ♦ Integrated Quadrature Phase Shifters
- ♦ Self-Biased Differential Baseband Inputs
- ♦ CMOS-Compatible Enable
- ♦ 4.1mA Operating Supply Current  
2µA Shutdown Supply Current

### Ordering Information

PART	TEMP. RANGE	PIN-PACKAGE
MAX2452ISE*	-20°C to +85°C	16 Narrow SO

\* An alternate marking, MAX2452CSE, has been identically tested.

### Functional Diagram

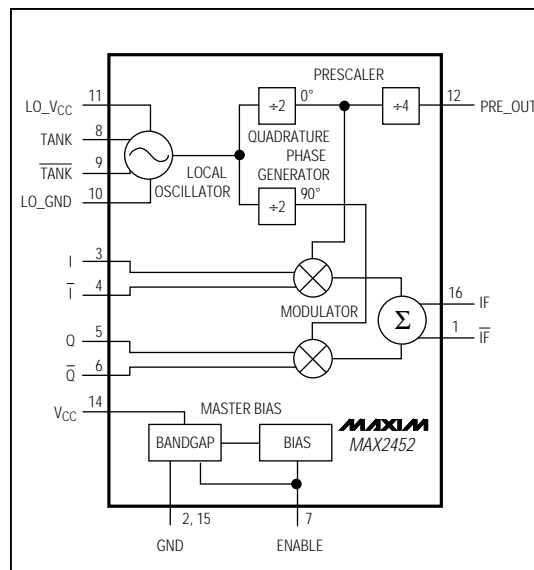

# 3V, Ultra-Low-Power Quadrature Modulator

## ABSOLUTE MAXIMUM RATINGS

V<sub>CC</sub>, LO\_V<sub>CC</sub> to GND ..... -0.3V to +4.5V  
 ENABLE, TANK,  $\overline{\text{TANK}}$ , I,  $\overline{\text{I}}$ , Q,  $\overline{\text{Q}}$  to GND ..... V<sub>CC</sub> + 0.3V  
 Continuous Power Dissipation (T<sub>A</sub> = +70°C)  
 SO (derate 8.33mW/°C above +70°C) ..... 667mW

Operating Temperature Range ..... -20°C to +85°C  
 Storage Temperature Range ..... -65°C to +165°C  
 Lead Temperature (soldering, 10sec) ..... +300°C

Stresses beyond those listed under "Absolute Maximum Ratings" may cause permanent damage to the device. These are stress ratings only, and functional operation of the device at these or any other conditions beyond those indicated in the operational sections of the specifications is not implied. Exposure to absolute maximum rating conditions for extended periods may affect device reliability.

## DC ELECTRICAL CHARACTERISTICS

(V<sub>CC</sub> = LO\_V<sub>CC</sub> = 2.7V to 3.3V, T<sub>A</sub> = -20°C to +85°C, unless otherwise noted.)

PARAMETER	SYMBOL	CONDITIONS	MIN	TYP	MAX	UNITS
Supply Voltage Range	V <sub>CC</sub> , LO_V <sub>CC</sub>		2.7		3.3	V
Supply Current	I <sub>CC ON</sub>	Enable = V <sub>CC</sub> - 0.4V		4.1	7	mA
Shutdown Supply Current	I <sub>CC OFF</sub>	Enable = 0.4V		2	20	μA
Enable/Disable Time	t <sub>ON/OFF</sub>			10		μs
ENABLE Bias Current	I <sub>EN</sub>	Enable = V <sub>CC</sub> - 0.4V		1	10	μA
ENABLE Low Voltage	V <sub>ENL</sub>				0.4	V
ENABLE High Voltage	V <sub>ENH</sub>		V <sub>CC</sub> - 0.4			V
IF Voltage Level	V <sub>IF</sub>		V <sub>CC</sub> - 1.7		V <sub>CC</sub> - 1.35	V
$\overline{\text{IF}}$ Voltage Level	V $\overline{\text{IF}}$		V <sub>CC</sub> - 1.7		V <sub>CC</sub> - 1.35	V
TANK Voltage Level	V <sub>TANK</sub>		LO_V <sub>CC</sub> - 1.1		LO_V <sub>CC</sub> - 0.8	V
$\overline{\text{TANK}}$ Voltage Level	V $\overline{\text{TANK}}$		LO_V <sub>CC</sub> - 1.1		LO_V <sub>CC</sub> - 0.8	V
I, $\overline{\text{I}}$ , Q, $\overline{\text{Q}}$ Voltage Level	V <sub>I</sub> , V $\overline{\text{I}}$ , V <sub>Q</sub> , V $\overline{\text{Q}}$		1.25	1.5	1.75	V
Differential Input Impedance	Z <sub>Ii</sub> , Z <sub>O<math>\overline{\text{Q}}</math></sub>		35	44		kΩ

## AC ELECTRICAL CHARACTERISTICS

(V<sub>CC</sub> = LO\_V<sub>CC</sub> = 3.0V, f<sub>OSC</sub> = 140MHz, ENABLE = 2.6V, f<sub>IF</sub> = f<sub>O $\overline{\text{Q}}$</sub>  = 600kHz, T<sub>A</sub> = -20°C to +85°C, unless otherwise noted.)

PARAMETER	SYMBOL	CONDITIONS	MIN	TYP	MAX	UNITS
Differential Input Voltage	V <sub>Ii</sub> p-p, V <sub>O<math>\overline{\text{Q}}</math></sub> p-p	(Note 1)		1.2	1.35	Vp-p
I and Q Signal Bandwidth	BW <sub>IQ</sub>	(Note 1)			15	MHz
IF Differential Output Voltage	V <sub>IF</sub> $\overline{\text{IF}}$ p-p	V <sub>Ii</sub> = V <sub>O<math>\overline{\text{Q}}</math></sub> = 1.2Vp-p, R <sub>L</sub> = 200kΩ differential, C <sub>L</sub> < 5pF differential		65		mVp-p
I/Q Amplitude Match				< ±0.3		dB
I/Q Phase Match				< ±3		degrees
Sideband Rejection				42		dB
LO Leakage at Output		V <sub>Ii</sub> = V <sub>O<math>\overline{\text{Q}}</math></sub> = 1.2Vp-p		-36		dBc
Oscillator Frequency Range	f <sub>OSC</sub>	(Notes 1, 2)	70	140	160	MHz
PRE_OUT Output Voltage	V <sub>PRE_OUT</sub>	R <sub>L</sub> = 10kΩ, C <sub>L</sub> < 6pF		0.35		Vp-p
PRE_OUT Slew Rate	SR <sub>PRE_OUT</sub>	R <sub>L</sub> = 10kΩ, C <sub>L</sub> < 6pF, rising edge, T <sub>A</sub> = +25°C		60		V/μs

**Note 1:** Guaranteed by design, not tested.

**Note 2:** The frequency range can be extended in either direction, but has not been characterized. At higher frequencies, the IF output level may decrease and distortions may increase.

# 3V, Ultra-Low-Power Quadrature Modulator

MAX2452

## Typical Operating Characteristics

( $V_{CC} = LO\_V_{CC} = 3.0V$ ,  $f_{OSC} = 140MHz$ ,  $ENABLE = 2.6V$ ,  $f_{IF} = f_{QO} = 600kHz$ ,  $R_L (IF, \bar{IF}) = 200k\Omega$  differential,  $C_L (IF, \bar{IF}) < 5pF$  differential,  $T_A = +25^\circ C$ , unless otherwise noted.)

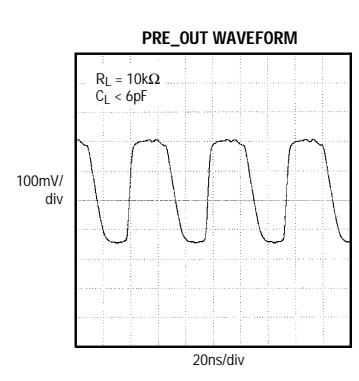
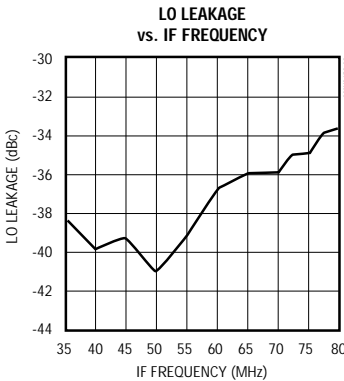
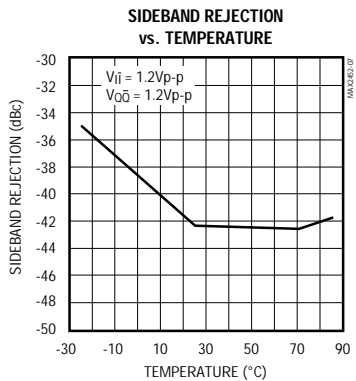
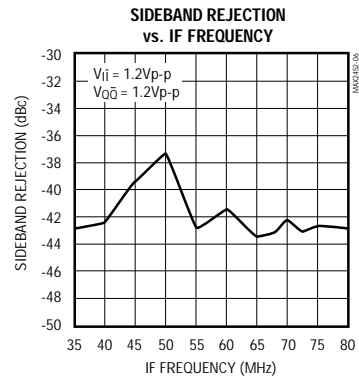
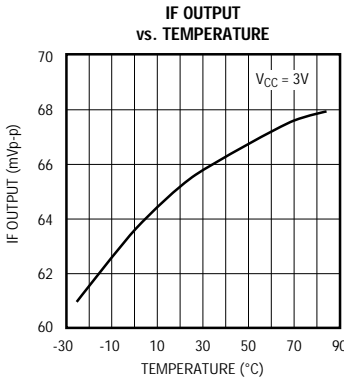
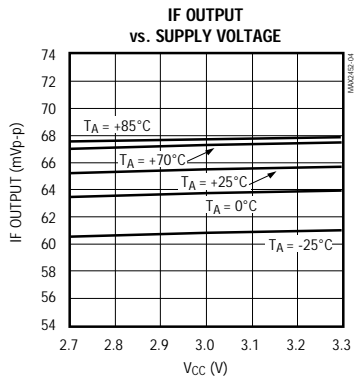
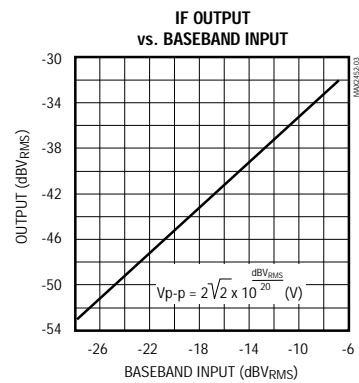
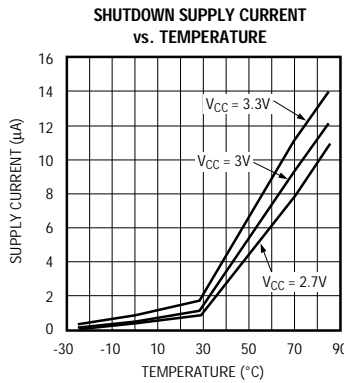
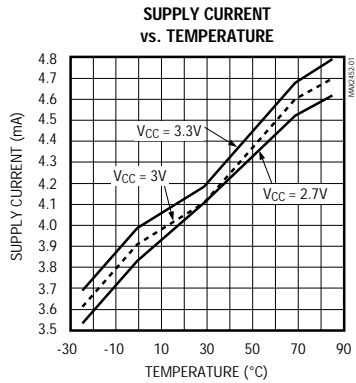

## 3V, Ultra-Low-Power Quadrature Modulator

### Typical Operating Characteristics (continued)

( $V_{CC} = LO\_V_{CC} = 3.0V$ ,  $f_{OSC} = 140MHz$ ,  $ENABLE = 2.6V$ ,  $f_{IF} = f_{OQ} = 600kHz$ ,  $R_L (IF, \overline{IF}) = 200k\Omega$  differential,  $C_L (IF, \overline{IF}) < 5pF$  differential,  $T_A = +25^\circ C$ , unless otherwise noted.)

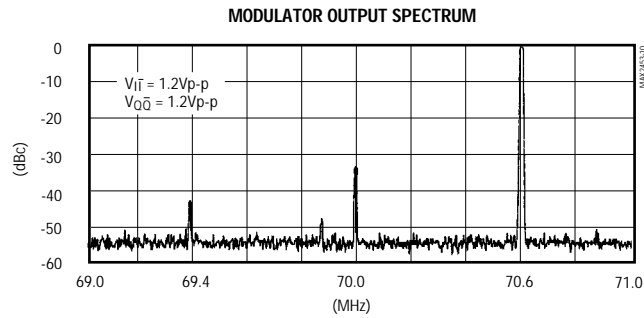

### Pin Description

PIN	NAME	FUNCTION
1	$\overline{IF}$	IF Inverting Output
2, 15	GND	Ground
3	I	Inphase Input
4	$\overline{I}$	Inphase Inverting Input
5	Q	Quadrature Input
6	$\overline{Q}$	Quadrature Inverting Input
7	ENABLE	Enable Control, active high
8	TANK	Local-Oscillator Resonant Tank Input
9	$\overline{TANK}$	Local-Oscillator Resonant Tank Inverting Input
10	LO_GND	Local-Oscillator Ground
11	LO_VCC	Local-Oscillator Supply
12	PRE_OUT	Local-Oscillator Divide-by-8 Prescaled Output
13	N.C.	No Connect, no internal connection to this pin
14	VCC	Modulator Supply
16	IF	IF Output

# 3V, Ultra-Low-Power Quadrature Modulator

MAX2452

## Detailed Description

The MAX2452 quadrature modulator integrates several important RF functions on a single chip. It includes differential buffers for the baseband inputs, two double-balanced mixers, a local oscillator, a quadrature phase generator, and a divide-by-8 prescaler. The prescaler simplifies the implementation of a phase-locked loop. Each of the functional blocks (shown in the *Functional Diagram*) is described in detail in the following sections.

### Local Oscillator

The local-oscillator section is formed by an emitter-coupled differential pair. Figure 1 shows the equivalent local-oscillator circuit schematic. An external LC resonant tank determines the oscillation frequency, and the Q of this resonant tank determines the phase noise of the oscillator. The oscillation frequency is twice the IF frequency, so that the quadrature phase generator can use two latches to generate precise quadrature signals.

### Quadrature Phase Generator

The quadrature phase generator uses two latches to divide the local-oscillator frequency by two, and generates two precise quadrature signals. Internal limiting amplifiers shape the signals to approximate square waves to drive the Gilbert-cell mixers in the modulator. The inphase signal (at half the local-oscillator frequency) is further divided by four for an external phase-locked loop.

### Modulator

The modulator accepts up to 1.35Vp-p I and Q differential baseband signals up to 15MHz, and upconverts them to higher-frequency IF signals. Since these inputs are biased internally at around 1.5V, you can improve carrier suppression by externally capacitively coupling the signals into these high-impedance ports (the differential input impedance is approximately 44k $\Omega$ ). The self-bias design is for very low on-chip offset, resulting in excellent carrier suppression. The IF output is designed to drive a high impedance (>20k $\Omega$ ), such as an IF buffer or an upconverter mixer.

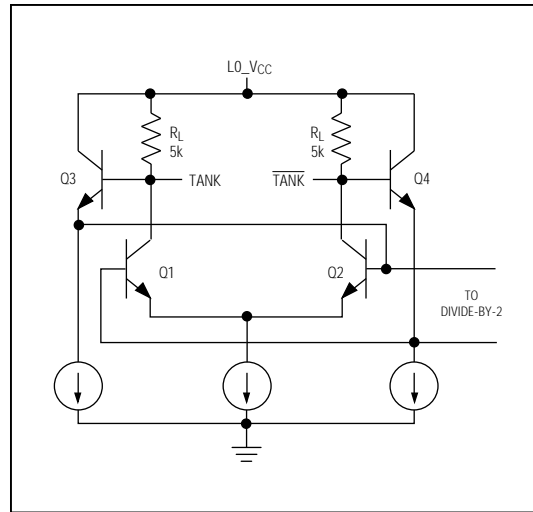

Figure 1. Local-Oscillator Equivalent Circuit

### Prescaler

The prescaler output, PRE\_OUT, is buffered and swings typically 0.35Vp-p with a 10k $\Omega$  and 6pF load. It can be AC-coupled to the input of a frequency synthesizer.

### Master Bias

During normal operation, ENABLE should remain above VCC - 0.4V. Pulling the ENABLE input low shuts off the master bias and reduces the circuit current to 2 $\mu$ A. The master bias section includes a bandgap reference generator and a PTAT (Proportional To Absolute Temperature) current generator.

# 3V, Ultra-Low-Power Quadrature Modulator

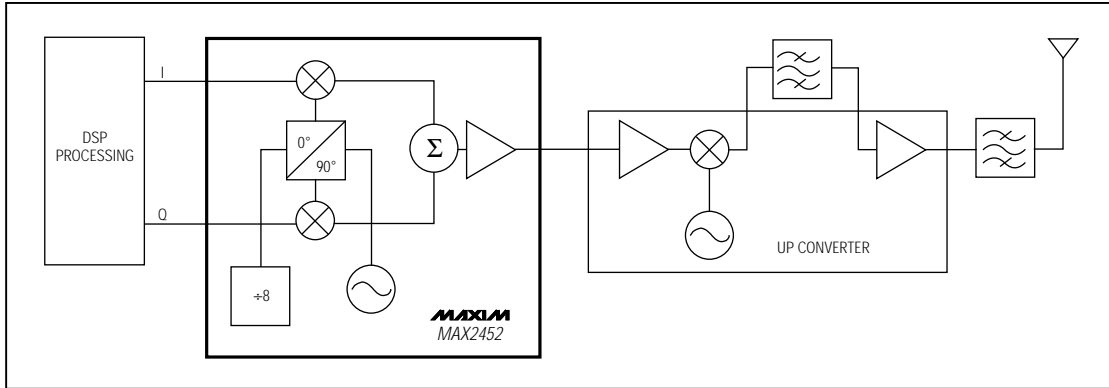

Figure 2. Typical Application Block Diagram

## Applications Information

The MAX2452 quadrature modulator is designed to upconvert I and Q baseband signals to IF frequencies up to 80MHz. Figure 2 shows a typical application block diagram, in which the MAX2452 is used for the first upconversion in a dual-conversion transmitter.

Figure 3 shows an implementation of a resonant tank circuit. The inductor, two capacitors, and a dual varactor form the resonant circuit of the oscillator. The frequency range of the oscillator shown in Figure 3 is 130MHz to 160MHz. The inductor is directly connected across the local oscillator's tank ports so that it will not lock up the oscillator in a stable state during start-up. The two 33pF capacitors increase the Q of the resonant circuit and reduce the VCO gain. They can be changed to meet individual applications requirements. The oscillation frequency can be determined using the following formula:

$$f_o = \frac{1}{2\pi\sqrt{L_{EQ} C_{EQ}}}$$

where

$$C_{EQ} = \frac{1}{\frac{1}{C_1} + \frac{1}{C_2} + \frac{2}{C_{VAR}}} + C_{STRAY}$$

and

$$L_{EQ} = L + L_{STRAY}$$

CSTRAY, LSTRAY: parasitic capacitance and inductance.

To alter the oscillation frequency range, change the inductance, the capacitance, or both. Make sure the Q of the resonant tank does not drop below 35.

$$Q = R_{EQ} \sqrt{\frac{C_{EQ}}{L_{EQ}}}$$

where  $R_{EQ} = 10k\Omega$  (see Figure 1).

The oscillation frequency can be changed by altering the control voltage, VCTRL.

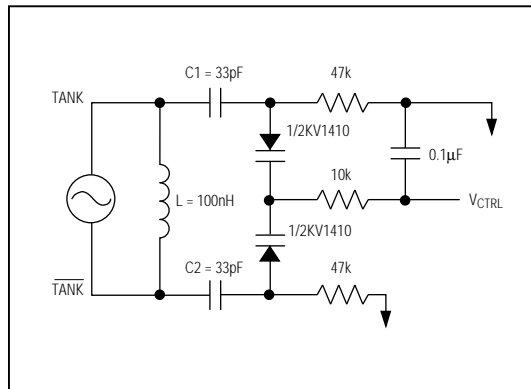
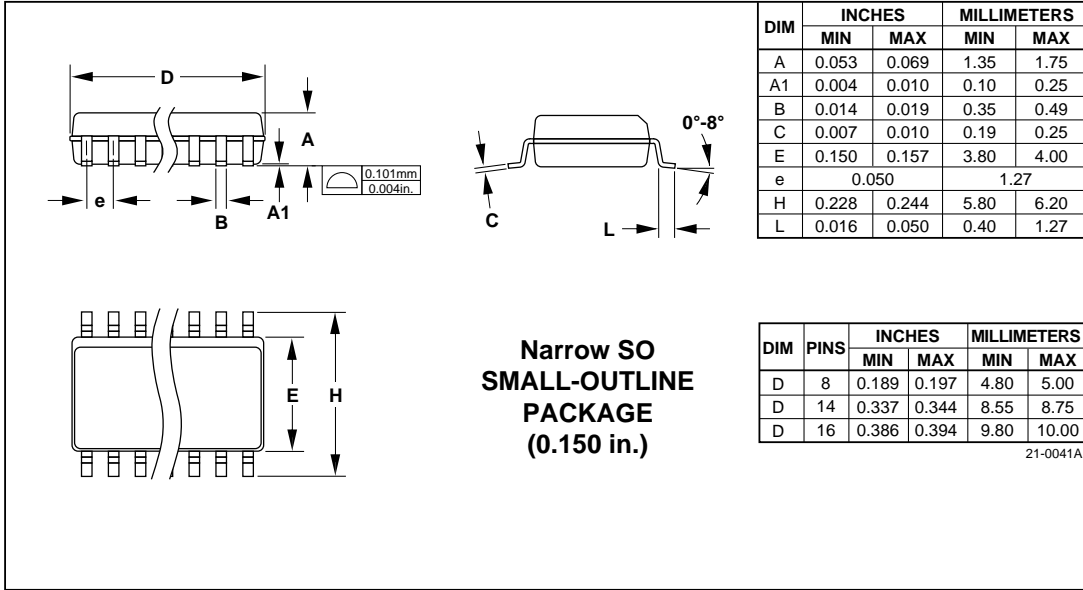

Figure 3. Typical Resonant Tank Circuit

# 3V, Ultra-Low-Power Quadrature Modulator

## Package Information

MAX2452



# 3V, Ultra-Low-Power Quadrature Modulator

MAX2452

*Maxim cannot assume responsibility for use of any circuitry other than circuitry entirely embodied in a Maxim product. No circuit patent licenses are implied. Maxim reserves the right to change the circuitry and specifications without notice at any time.*

8 \_\_\_\_\_ Maxim Integrated Products, 120 San Gabriel Drive, Sunnyvale, CA 94086 (408) 737-7600

© 1995 Maxim Integrated Products

Printed USA

**MAXIM** is a registered trademark of Maxim Integrated Products.