

M62293FP

3.3V, 2.5V FIXED 2-OUTPUT VOLTAGE DC-DC CONVERTER

DESCRIPTION

M62293FP is 3.3V and 2.5V fixed stable 2-output step-down DC-DC converter.

It is possible to simplify peripheral circuit and to design compact and low cost sets because this device includes peripheral devices in small size 8pin package.

The IC also has Reset circuit with time delay that monitors power supply($V_{cc}=5V$) and one regulator output($V_{out1}=3.3V$;IN1 terminal), therefore an application system is protected system errors.

Especially this is most suitable for application system with microprocessor and ASIC.

FEATURES

- 3.3V and 2.5V step-down converter
- 4 to 15V wide input supply voltage ($V_{cc}=5V$ typ.)
- Reset circuit with time delay monitors supply voltage($V_{cc}=5V$)and regulator output (3.3V)
- 110kHz fixed frequency oscillator without peripheral devices
- 8pin SOP package

APPLICATION

application system with microprocessor and ASIC

PIN CONFIGURATION(TOP VIEW)

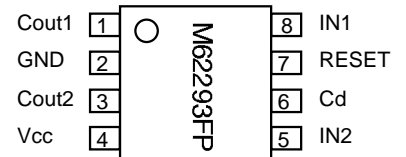

Outline 8P2S-A

BLOCK DIAGRAM

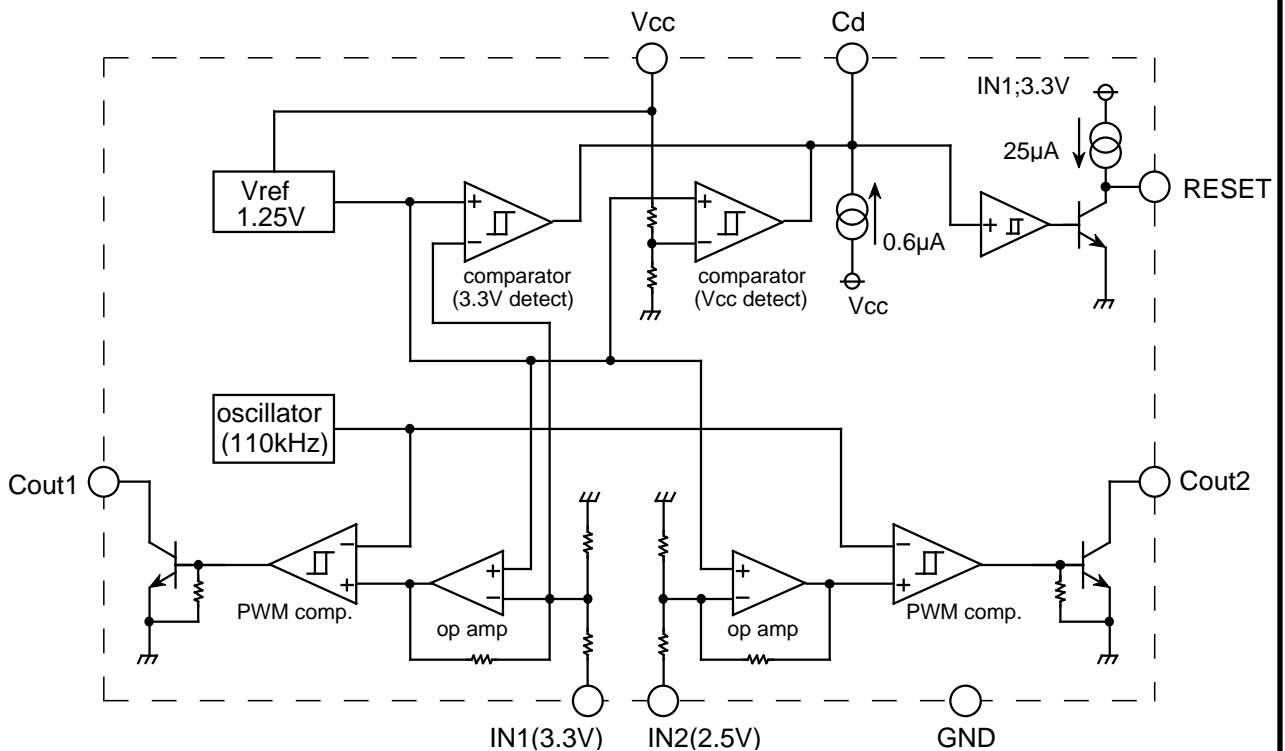

M62293FP**3.3V, 2.5V FIXED 2-OUTPUT VOLTAGE DC-DC CONVERTER****ABSOLUTE MAXIMUM RATINGS(Ta=25C,unless otherwise noted)**

Symbol	Parameter	Conditions	Ratings	Unit
Vcc	Supply voltage		16	V
Io	Output current(DC-DC converter block)	ch1,ch2	30	mA
IoRESET	Output current(Reset block)		6	mA
Pd	Power dissipation	Ta=25°C	440	mW
K	Thermal derating	Ta>25°C	4.4	mW/°C
Topr	Operating temperature		-20~+85	°C
Tstg	Storage temperature		-40~+125	°C

ELECTRICAL CHARACTERISTICS(Ta=25C,Vcc=5V,unless otherwise noted)

Block	Symbol	Parameter	Test condition	Limits			Unit
				Min.	Typ.	Max.	
All Blocks	Vcc	Supply voltage		4.0	5.0	15	V
	Icc	Supply current	Without load	-	1.5	2.8	mA
DC-DC Converter Block							
Error Amp.	Vo1	Output voltage	ch1 output	3.15	3.30	3.45	V
	Vo2		ch2 output	2.37	2.50	2.63	
	Vreg-L	Line regulation	Vcc=4~12V	-	5	15	mV
	Iin	Input current 1	ch1	-	150	450	μA
	Iin	Input current 2	ch2	-	100	300	μA
Oscillator	fosc	Oscillator frequency		65	110	160	KHz
Output	TDUTY	Maximum ON duty		-	90	-	%
	ICL	Output leakage current	Vcc=12V, Vc=12V	-1	-	1	V
	Vsat	Output saturation voltage	Io=10mA,Darlington connection	-	1.2	2.0	V
Reset circuit Block							
Reset Circuit	Vs1	Detecting voltage 1	Vcc=5V detection	3.6	3.8	4.0	V
	Vs1	hysterisys voltage 1		30	50	80	mV
	Vs2	Detecting voltage 2	ch1output(3.3V)detection	2.46	2.58	2.70	V
	Vs2	Hysterisys voltage 2		30	50	80	mV
	IPD	Cd output current		-1.1	-0.6	-0.3	μA
	tpd	Delay time	Cd=4700pF	5	10	20	msec
	IOC	RESET output current	Vcc=5V, Vo=1/2 x Vcc	-40	-25	-17	μA
	VOL	RESET LOW voltage	IoRESET=4mA	-		0.2Vo1	V
	VOH	RESET High voltage		0.8Vo1		-	V

M62293FP

3.3V, 2.5V FIXED 2-OUTPUT VOLTAGE DC-DC CONVERTER

RESET BLOCK timing chart

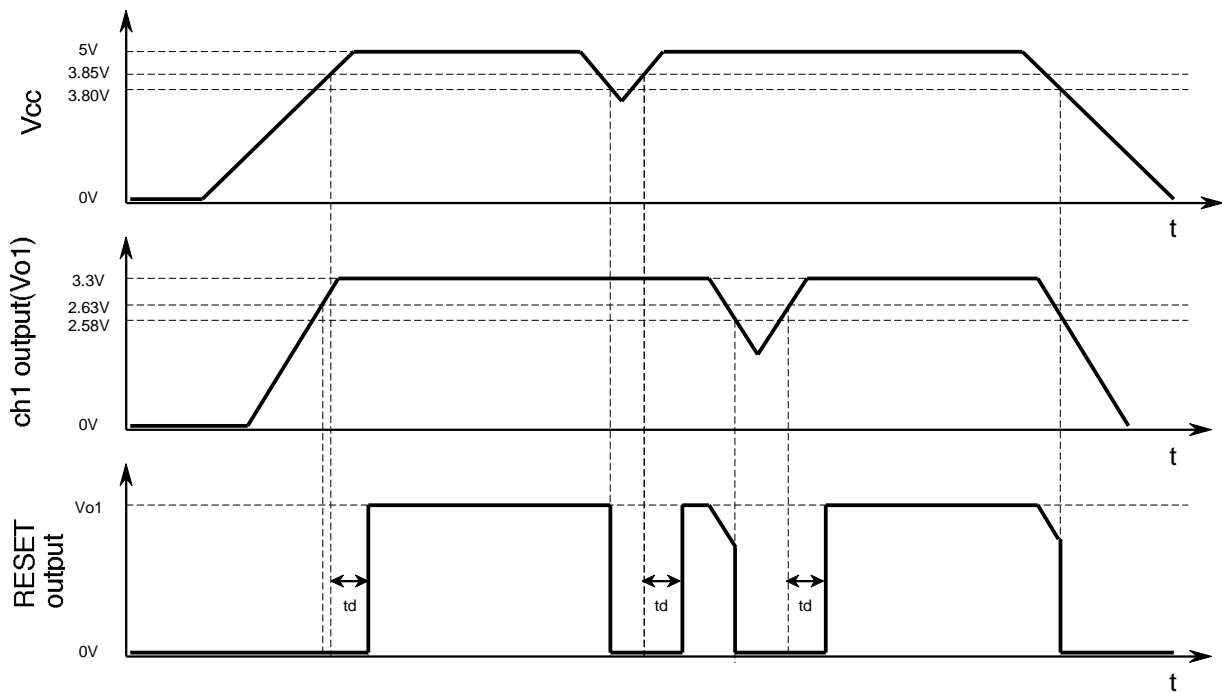

t_d : RESET Delay Time ●●●

$$t_d(\text{msec}) \cong 2.13 \times 10^{-3} \times C_d(\text{pF})$$

M62293FP

3.3V, 2.5V FIXED 2-OUTPUT VOLTAGE DC-DC CONVERTER

APPLICATION CIRCUIT (3.3V and 2.5V 2-output voltage DC-DC converter)

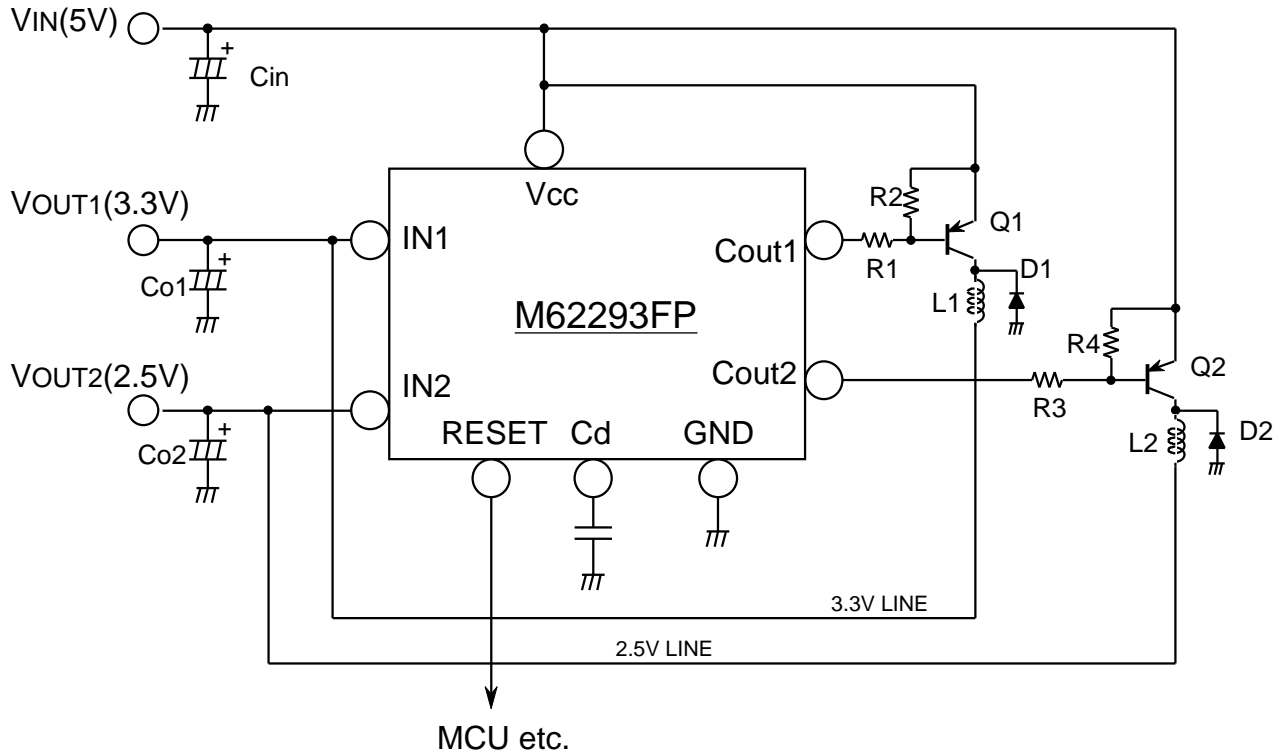

THE EXPRESSION OF CIRCUIT CONSTANTS

Constants	Expressions
$\frac{TON}{TOFF}$	$\frac{VO+VF}{VIN - VCE(sat) - VO}$
$(TON+TOFF)MAX$	$\frac{1}{fosc}$ fosc:110KHz(Vcc=5V)
TOFF(MIN)	$(TON + TOFF) / (1 + \frac{TON}{TOFF})$
TON(MAX)	$\frac{1}{fosc} - TOFF$
L(MIN)	$\frac{(VIN - VCE(sat) - VO) \times TON(MAX)}{Io}$
IpK	$Io + \frac{1}{2} Io$

note:

- VF : Forward voltage drop of an external diode
- Vsat : Output saturation voltage of an external switching transistor.
- IO : Set to 1/3 to 1/5 of maximum output current.
- Choose an external transistor, diode and inductor with peak current rating approximately greater than "IpK".