

M57704H

450-470MHz, 12.5V, 13W, FM MOBILE RADIO

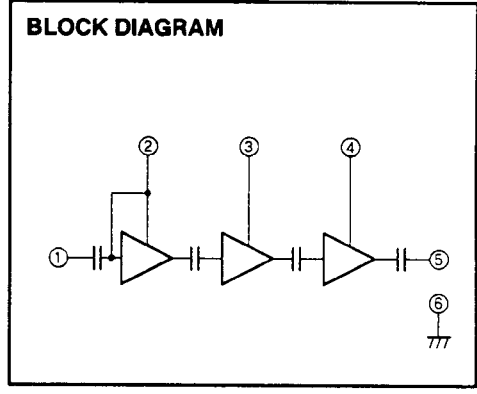
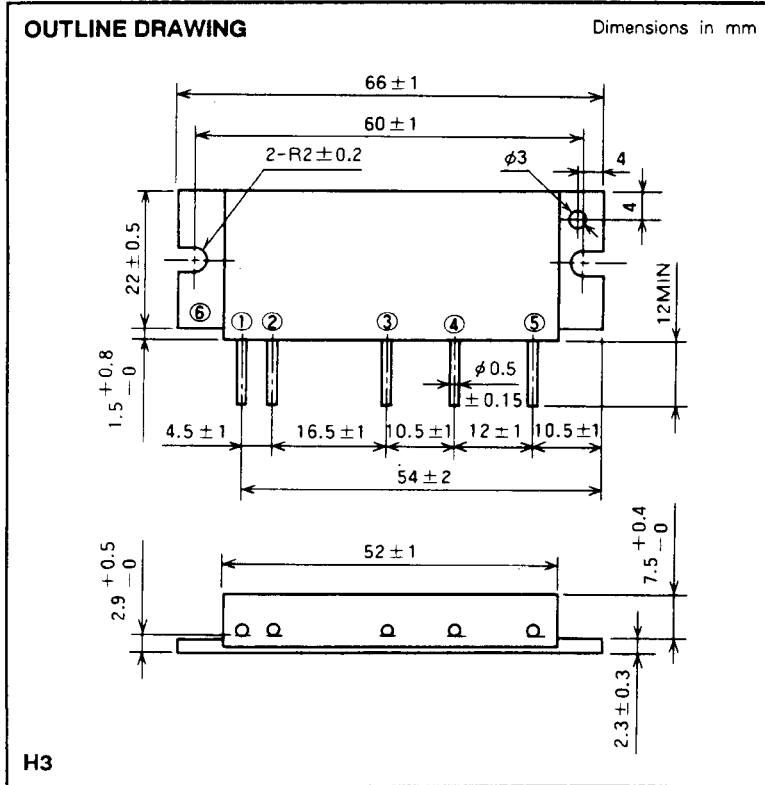

- PIN :
- ① Pin : RF INPUT
 - ② Vcc1 : 1st. DC SUPPLY
 - ③ Vcc2 : 2nd. DC SUPPLY
 - ④ Vcc3 : 3rd. DC SUPPLY
 - ⑤ Po : RF OUTPUT
 - ⑥ GND : FIN

ABSOLUTE MAXIMUM RATINGS (Tc = 25°C unless otherwise noted)

Symbol	Parameter	Conditions	Ratings	Unit
Vcc	Supply voltage		17	V
Icc	Total current		5	A
P _{in(max)}	Input power	Z _G = Z _L = 50 Ω	0.4	W
P _{O(max)}	Output power	Z _G = Z _L = 50 Ω	20	W
T _{C(OP)}	Operation case temperature		- 30 to 110	°C
T _{stg}	Storage temperature		- 40 to 110	°C

Note. Above parameters are guaranteed independently.

ELECTRICAL CHARACTERISTICS (Tc = 25°C unless otherwise noted)

Symbol	Parameter	Test conditions	Limits		Unit
			Min	Max	
f	Frequency range	P _{in} = 0.2W Vcc = 12.5V Z _G = Z _L = 50 Ω	450	470	MHz
P _O	Output power		13		W
η _T	Total efficiency		35		%
2f _o	2nd. harmonic		- 30		dBc
ρ _{in}	Input VSWR		2.8		-
-	Load VSWR tolerance	Vcc = 15.2V, P _O = 14W (P _{in} : controlled) Load VSWR=20:1(All phase), 2sec. Z _G = 50 Ω	No degradation or destroy		-

Note. Above parameters, ratings, limits and conditions are subject to change.

TYPICAL PERFORMANCE DATA

OUTPUT POWER TOTAL EFFICIENCY INPUT VSWR VS. FREQUENCY

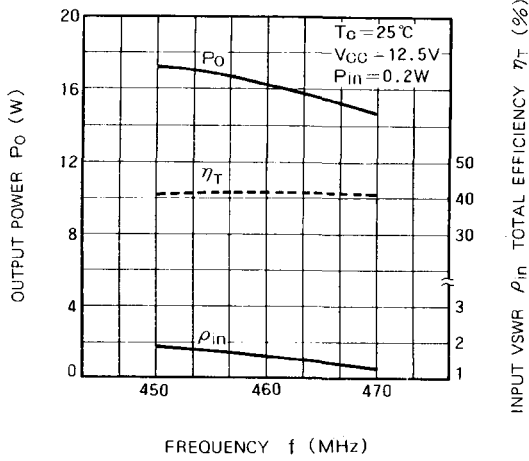

OUTPUT POWER TOTAL EFFICIENCY VS. INPUT POWER

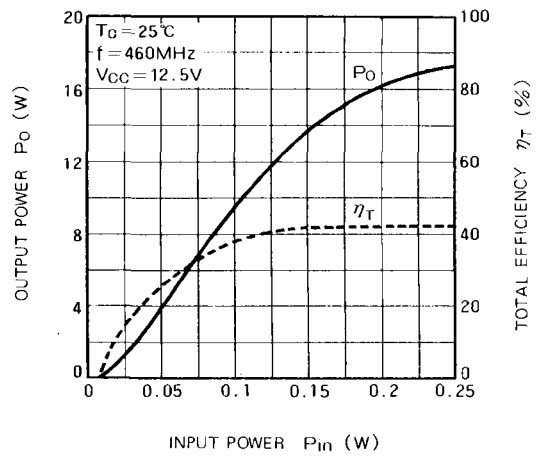

OUTPUT POWER VS. DC SUPPLY VOLTAGE

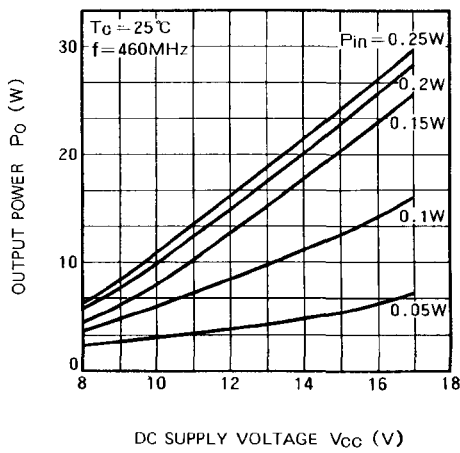

OUTPUT POWER VS. 1st AND 2nd VOLTAGE

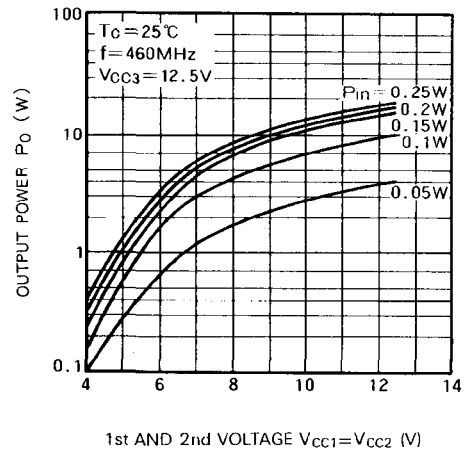

INPUT IMPEDANCE OUTPUT IMPEDANCE

