

**PROGRAMMABLE SHUNT REGULATOR**

The KA431/A are three-terminal adjustable regulator series with a guaranteed thermal stability over applicable temperature ranges. The output voltage may be set to any value between  $V_{REF}$  (approximately 2.5 volts) and 36 volts with two external resistors. These devices have a typical dynamic output impedance of  $0.2\Omega$ . Active output circuitry provides a very sharp turn-on characteristic, making these devices excellent replacement for zener diodes in many applications.

**FEATURES**

- Programmable output voltage to 36 volts
- Low dynamic output impedance 0.20 typical
- Sink current capability of 1.0 to 100mA
- Equivalent full-range temperature coefficient of 50ppm/°C typical
- Temperature compensated for operation over full rated operating temperature range
- Low output noise voltage
- Fast turn on response

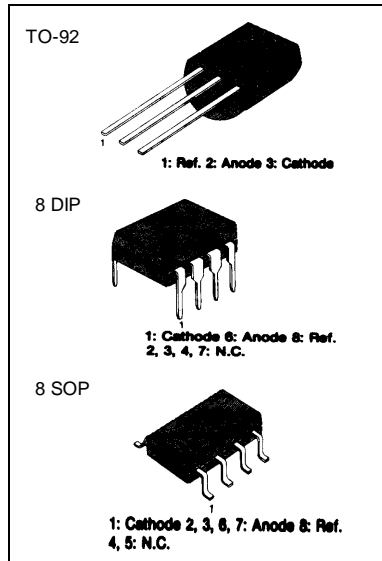

**BLOCK DIAGRAM**

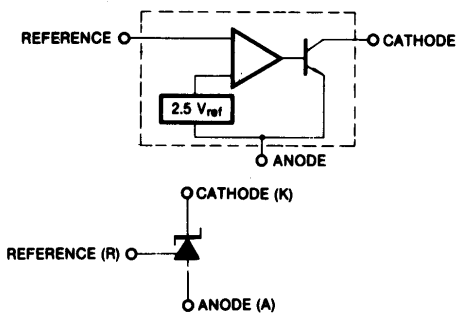

**ORDERING INFORMATION**

Device	Operating Temperature	Package
KA431Z	0~ +70°C	TO-92
KA431	0~ +70°C	8 DIP
KA431D	0~ +70°C	8 SOP
KA431AZ	0~ +70°C	TO-92
KA431AD	0~ +70°C	8 SOP
KA431LZ	0~ +70°C	TO-92

**ABSOLUTE MAXIMUM RATINGS**

(Operating temperature range applies unless otherwise specified.)

Characteristic	Symbol	Value	Unit
Cathode Voltage	$V_{KA}$	37	V
Cathode current Range (Continuous)	$I_{KA}$	-100 ~ + 150	mA
Reference Input Current Range	$I_{REF}$	0.05 ~ + 10	mA
Power Dissipation D, Z Suffix Package	$P_D$	770	mW
N Suffix Package		1000	mW
Operating Temperature Range	$T_{OPR}$	0 ~ + 70	°C
Storage Temperature Range	$T_{STG}$	-65 ~ + 150	°C

**RECOMMENDED OPERATING CONDITIONS**

Characteristic	Symbol	Min	Typ	Max	Unit
Cathode Voltage	$V_{KA}$	$V_{REF}$		36	V
Cathode Current	$I_{KA}$	1.0		100	mA

**ELECTRICAL CHARACTERISTICS** ( $T_A = 25^\circ\text{C}$ , unless otherwise specified)

Characteristic	Symbol	Test Conditions	KA431			KA431A			KA431L			Unit	
			Min	Typ	Max	Min	Typ	Max	Min	Typ	Max		
Reference Input Voltage	$V_{REF}$	$V_{KA}=V_{REF}, I_{KA}=10\text{mA}$	2.440	2.495	2.550	2.470	2.495	2.520	2.482	2.495	2.508	V	
Deviation of Reference Input Voltage Over-Temperature (Note 1)	$\Delta V_{REF}/\Delta T$	$V_{KA}=V_{REF}, I_{KA}=10\text{mA}$ $T_{MIN} \leq T_A \leq T_{MAX}$		4.5	17		4.5	17		4.5	17	mV	
Ratio of Change in Reference Input Voltage to the Change in Cathode Voltage	$\Delta V_{REF}/\Delta I_{KA}$	$I_{KA}=10\text{mA}$	$\Delta V_{KA}=10\text{V}-V_{REF}$		-10	-2.7	$-1.0$		-2.7	$-1.0$		-2.7	mV/W
			$\Delta V_{KA}=36\text{V}-10\text{V}$		-0.5	-2.0	$-0.5$		-2.0	$-0.5$		-2.0	
Reference Input Current	$I_{REF}$	$I_{KA}=10\text{mA}, R_1=10\text{K}\Omega, R_2=\infty$	1.5	4		1.5	4		1.5	4		$\mu\text{A}$	
Deviation of Reference Input Current Over Full Temperature Range	$\Delta I_{REF}/\Delta T$	$I_{KA}=10\text{mA}, R_1=10\text{K}\Omega, R_2=\infty$ $T_A=\text{Full Range}$	0.4	1.2		0.4	1.2		0.4	1.2		$\mu\text{A}$	
Minimum Cathode Current for Regulation	$I_{KA(MIN)}$	$V_{KA}=V_{REF}$	0.45	1.0		0.45	1.0		0.45	1.0		mA	
Off - Stage Cathode Current	$I_{KA(OFF)}$	$V_{KA}=36\text{V}, V_{REF}=0$	0.05	1.0		0.05	1.0		0.05	1.0		$\mu\text{A}$	
Dynamic Impedance (Note 2)	$Z_{KA}$	$V_{KA}=V_{REF}, I_{KA}=1$ to 100mA $f \geq 1.0\text{K}\Omega$	0.15	0.5		0.15	0.5		0.15	0.5		$\Omega$	

 $T_{MIN}=0^\circ\text{C}, T_{MAX}=+70^\circ\text{C}$

TEST CIRCUITS

Fig. 1 Test Circuit for  $V_{KA} = V_{REF}$

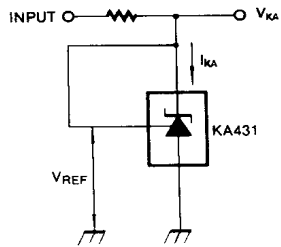
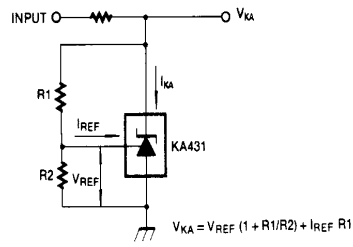
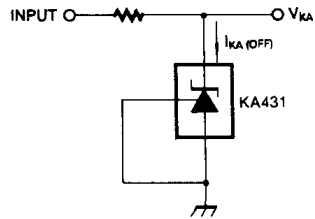

Fig. 2 Test Circuit for  $V_{KA} \geq V_{REF}$



$$V_{KA} = V_{REF} (1 + R1/R2) + I_{REF} R1$$

Fig. 3 Test Circuit for  $I_{KA(OFF)}$



TYPICAL PERFORMANCE CHARACTERISTICS

Fig. 4 CATHODE CURRENT VS CATHODE VOLTAGE

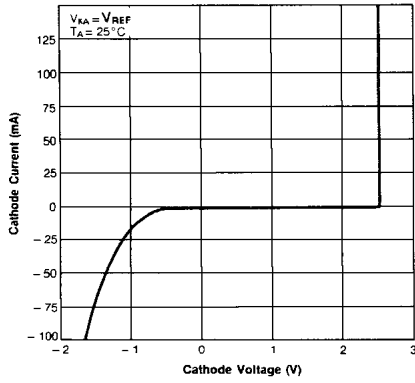

Fig. 5 CATHODE CURRENT VS CATHODE VOLTAGE

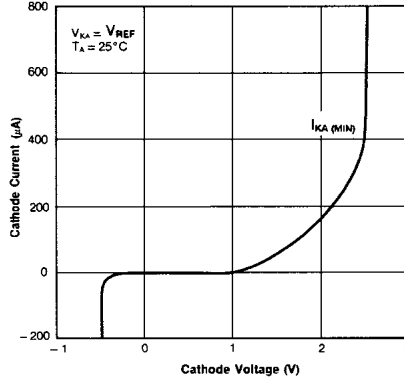

Fig. 6 CHANGE IN REFERENCE INPUT VOLTAGE VS CATHODE VOLTAGE

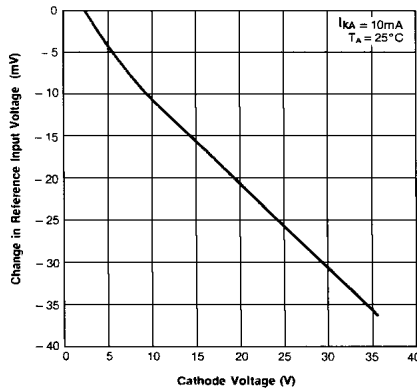

Fig. 7 DYNAMIC IMPEDANCE VS FREQUENCY

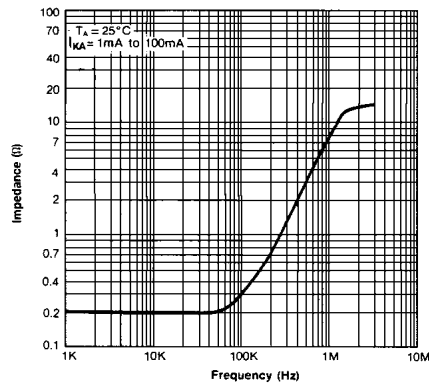
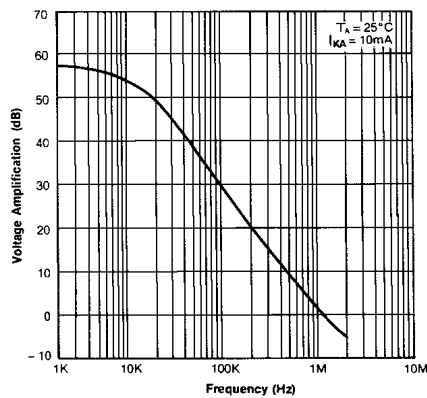
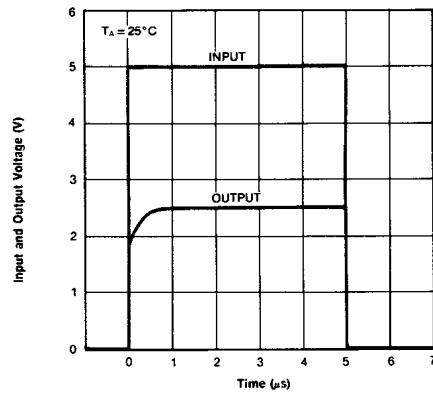

Fig. 8 SMALL SIGNAL VOLTAGE AMPLIFICATION VS FREQUENCY



TYPICAL PERFORMANCE CHARACTERISTICS

Fig. 9 PULSE RESPONSE



TYPICAL APPLICATIONS

Fig. 10 SHUNT REGULATOR

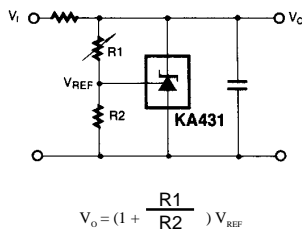

$$V_o = \left(1 + \frac{R_1}{R_2}\right) V_{REF}$$

Fig. 11 OUTPUT CONTROL OF A THREE-TERMINAL FIXED REGULATOR

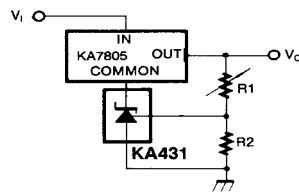

$$V_o = V_{REF} \left(1 + \frac{R_1}{R_2}\right)$$

Fig- 2 HIGHERCURRENT SHUNT REGULATOR

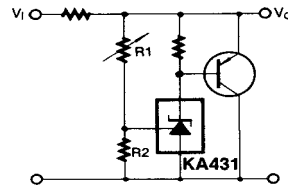

$$V_o = \left(1 + \frac{R_1}{R_2}\right) V_{REF}$$

## TYPICAL APPLICATIONS

Fig. 13 CURRENT LIMITER OR  
CURRENT SOURCE

Fig. 14 CONSTANT-CURRENT SINK



# 8-DIP-300

Dimensions in Millimeters/inches

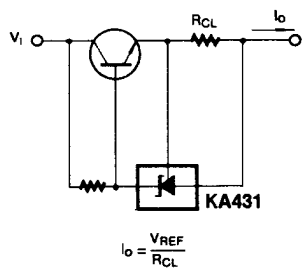
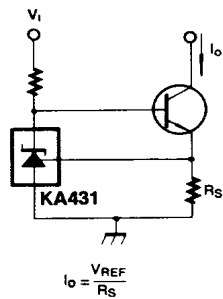
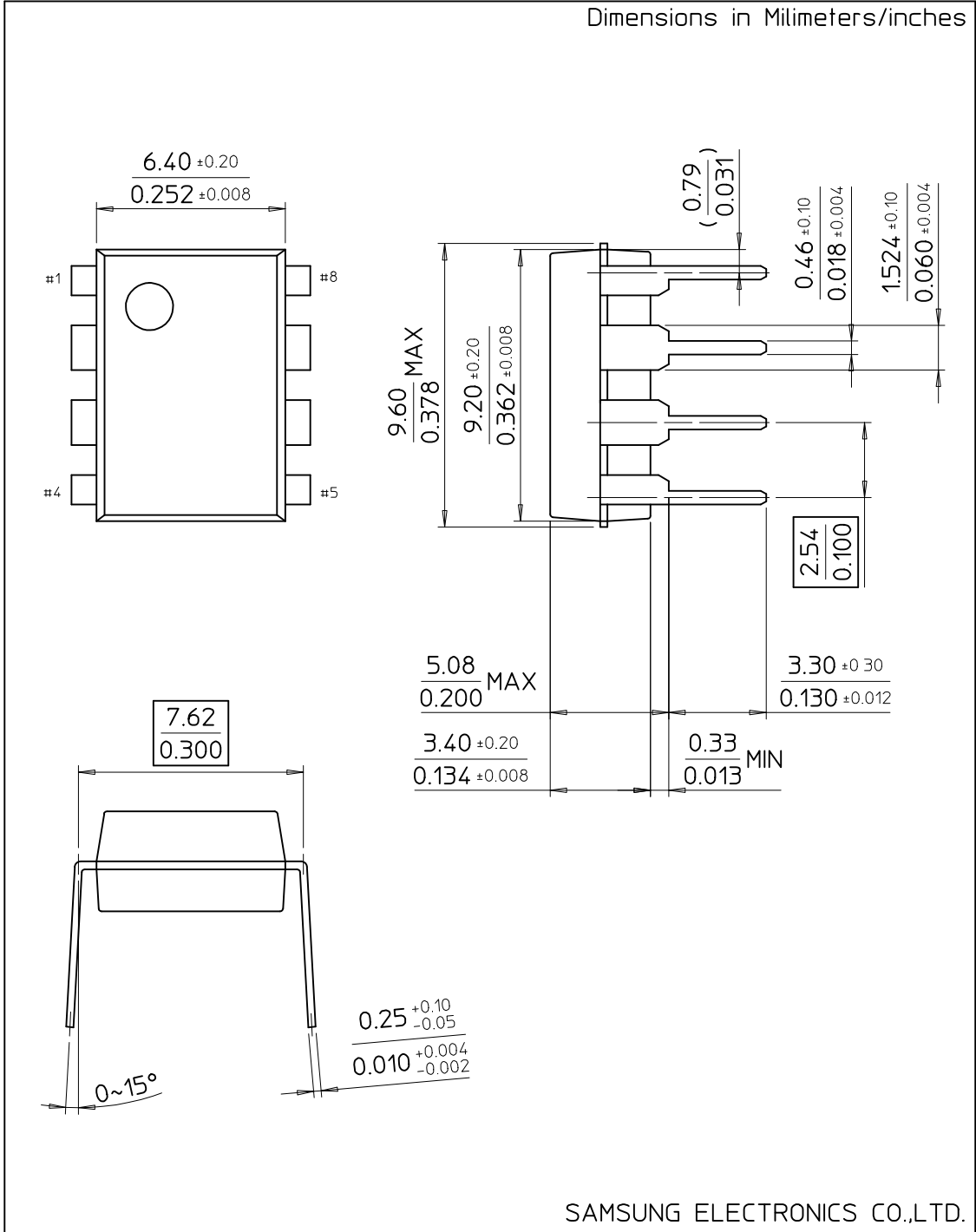

SAMSUNG ELECTRONICS CO.,LTD.

# 8-SOP-225

Dimensions in Millimeters/inches

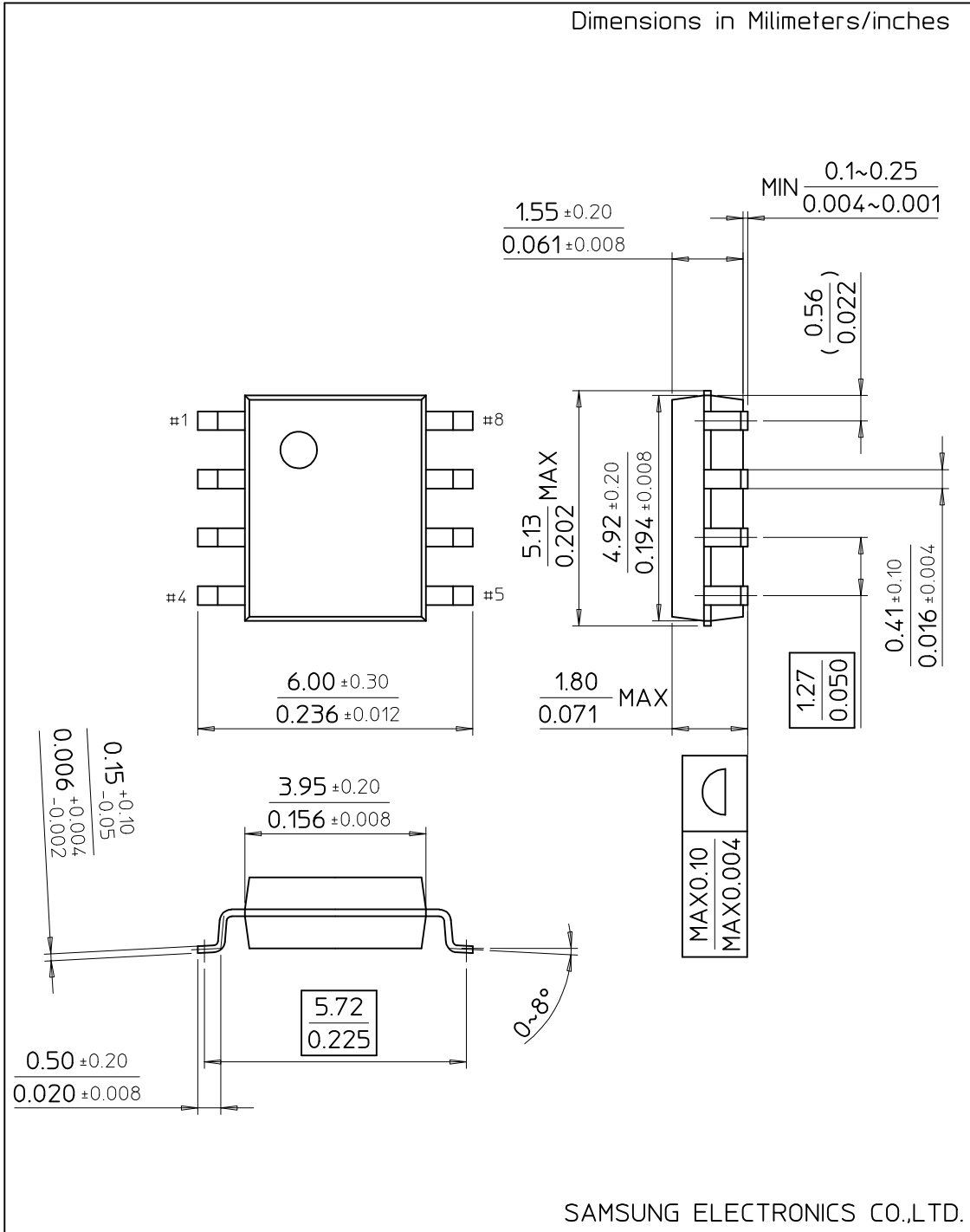

SAMSUNG ELECTRONICS CO.,LTD.



# TO-92

Dimensions in Millimeters

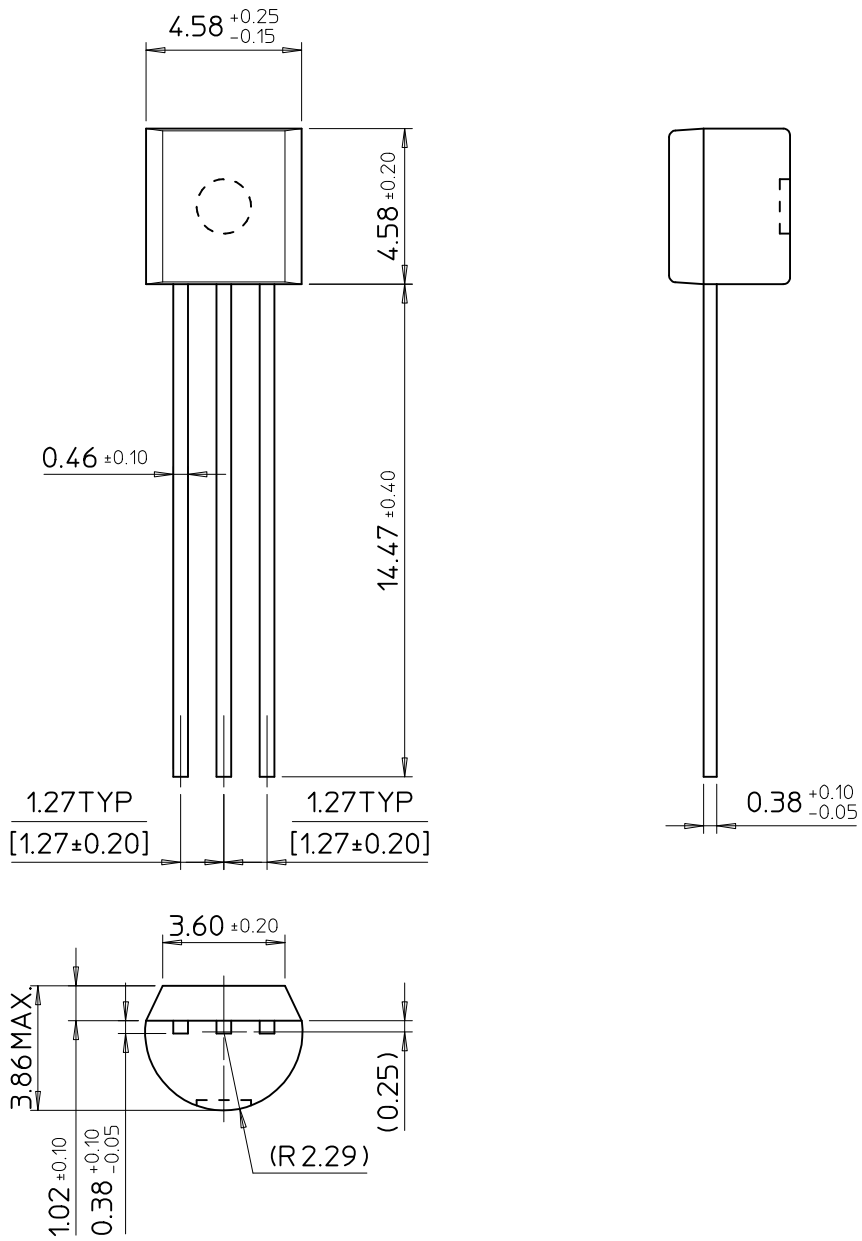

SAMSUNG ELECTRONICS CO.,LTD.