

### 4-CH MOTOR DRIVER

The KA3012D is a monolithic integrated circuit, and suitable for 4-CH motor driver which drives sled motor, loading motor, focus & tracking actuator of CD-ROM system and built in op-amp which can receive digital signal from servo of CD system.

### FEATURES

- BTL (H-Bridge type linear) 4channel motor driver
- Wide dynamic range:
  - $SV_{CC}=12V, PV_{CC1}=5V, RL=8\Omega \rightarrow V_{OM}=4.2V$
  - $SV_{CC}=12V, PV_{CC2}=12V, RL=24\Omega \rightarrow V_{OM}=10.4V$
- Built in level-shift circuit
- Built in op-amp for digital input
- Built in thermal shutdown (TSD) circuit
- Three independent sources
- Low crossover distortion
- Built-in reverse rotation prevented
- Built-in short breaker

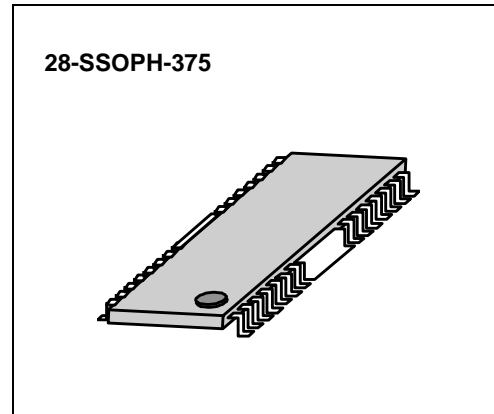

### ORDERING INFORMATION

Device	Package	Operating Temperature
KA3012D	28-SSOPH-375	-35°C ~ +85°C

### BLOCK DIAGRAM

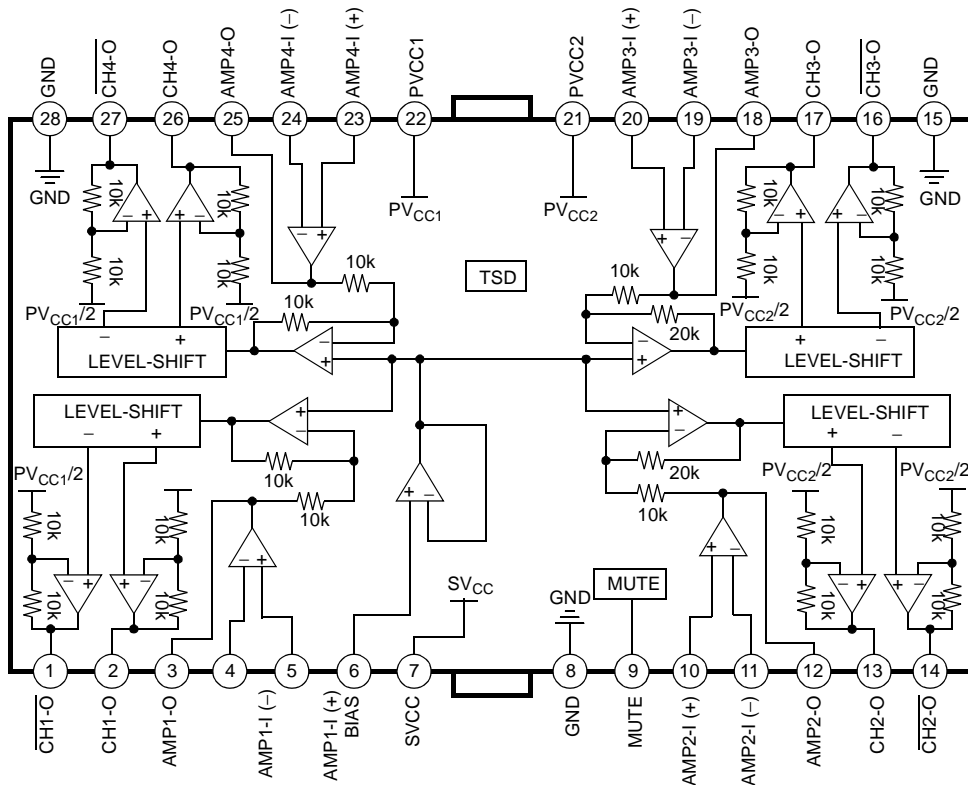

**NOTE:** The drive channel outputs are determined pre op-amp output.

## PIN CONFIGURATION

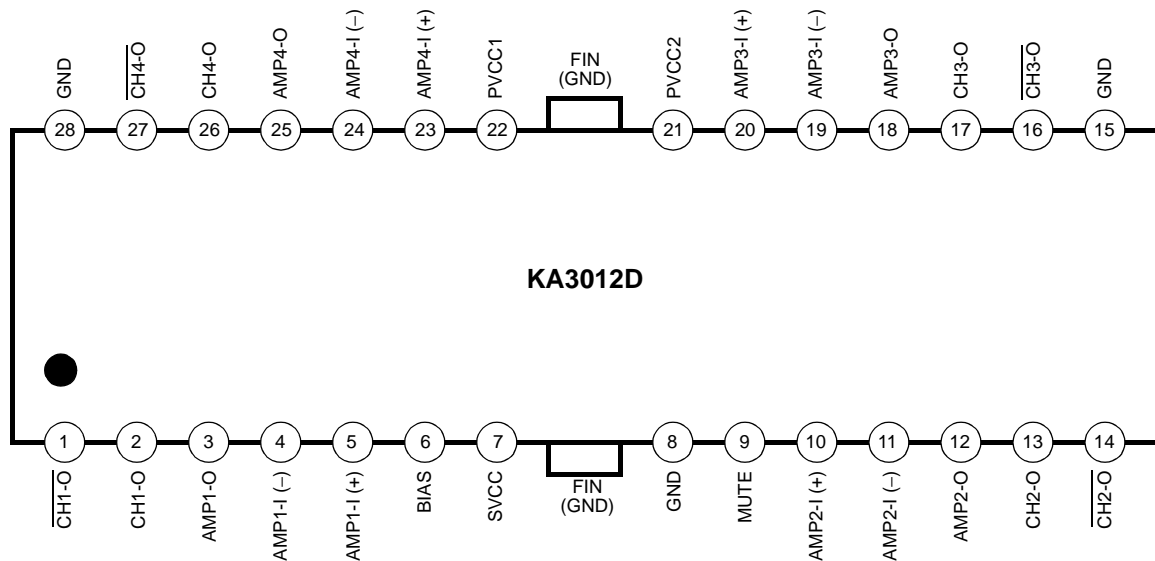

## PIN DESCRIPTION

Pin No.	Symbol	I/O	Description	Pin No.	Symbol	I/O	Description
1	CH1-O	O	Drive CH 1 output (-)	15	GND	-	Ground
2	CH1-O	O	Drive CH 1 output (+)	16	CH3-O	O	Drive CH 3 output (-)
3	AMP1-O	O	Op-amp CH 1 output	17	CH3-O	O	Drive CH 3 output (+)
4	AMP1-I(-)	I	Op-amp CH 1 input (-)	18	AMP3-O	O	OP-amp CH 3 output
5	AMP1-I(+)	I	Op-amp CH 1 input (+)	19	AMP3-I(-)	I	Drive CH 3 input (-)
6	BIAS	I	Bias input	20	AMP3-I(+)	I	Drive CH 3 input (+)
7	SVCC	-	Supply voltage (Signal)	21	PVCC2	-	Supply voltage (CH 2 & CH 3)
8	GND	-	Ground	22	PVCC1	-	Supply voltage (CH1 & CH 4)
9	MUTE	I	Mute	23	AMP4-I(+)	I	Op-amp CH 4 input (+)
10	AMP2-I(+)	I	Op-amp CH 2 input (+)	24	AMP4-I(-)	I	Op-amp CH 4 input (-)
11	AMP2-I(-)	I	Op-amp CH 2 input (-)	25	AMP4-O	O	Op-amp CH 4 output
12	AMP2-O	O	Op-amp CH 2 output	26	CH4-O	O	Drive CH 4 output (+)
13	AMP2-O	O	Op-amp CH 2 output (+)	27	CH4-O	O	Drive CH 4 output (-)
14	CH2-O	O	Op-amp CH 2 output (Op-amp CH 2 output)	28	GND	-	Ground

EQUIVALENT CIRCUITS

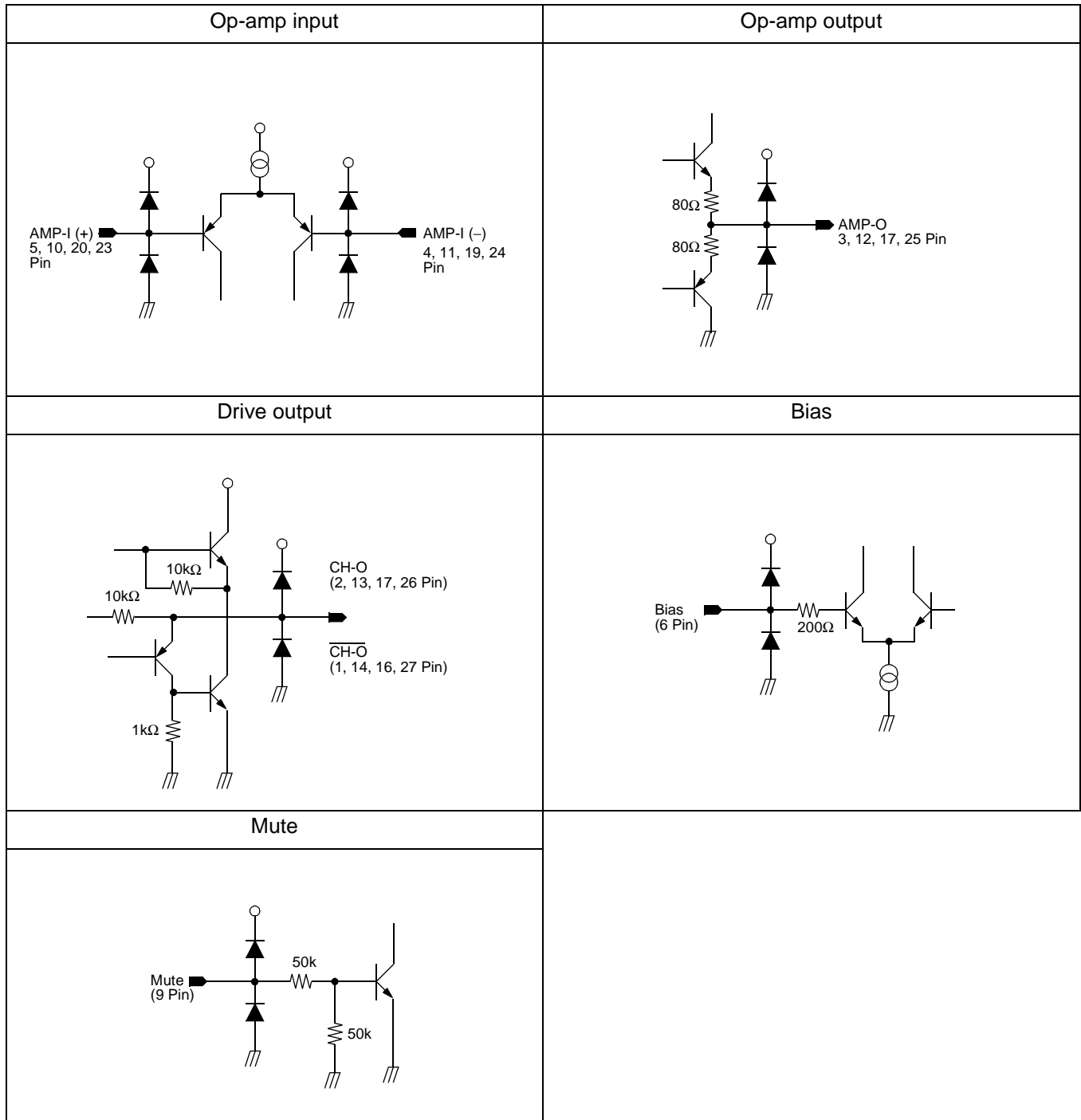

**ABSOLUTE MAXIMUM RATING (Ta=25°C)**

Characteristics	Symbol	Value	Unit
Supply voltage	$V_{CC}$	15	V
Power dissipation	$P_d$	1.7 (note)	W
Operating temperature range	$T_{OPR}$	-20 ~ +75	°C
Storage temperature range	$T_{STG}$	-55 ~ +150	°C

**NOTE:**

1. When mounted on 50mm × 50mm × 1mm PCB (Phenolic resin material).
2. Power dissipation reduces 13.6mW / °C for using above Ta=25°C.
3. Do not exceed Pd and SOA (Safe operating area).

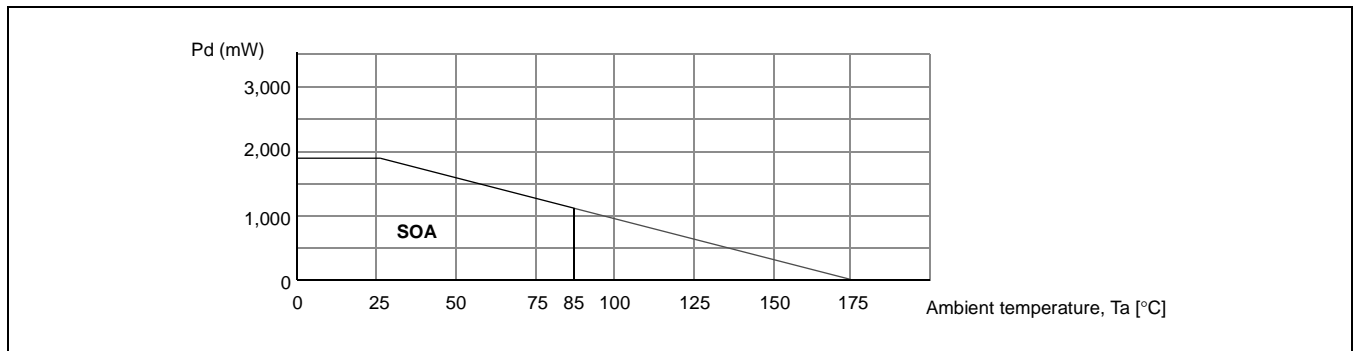
**RECOMMENDED OPERATING CONDITION (Ta=25°C)**

Characteristics	Symbol	Min.	Typ.	Max.	Unit
Supply voltage	$SV_{CC}, V_{CC1}, V_{CC2}$	4.5	–	13.2	V
Operating temperature	$T_{OPR}$	-35	–	+85	°C

## ELECTRICAL CHARACTERISTICS

(Ta=25°C, V<sub>CC1</sub>=V<sub>CC2</sub>=5V, R<sub>L</sub>=8Ω)

Characteristic	Symbol	Test conditions	Min.	Typ.	Max.	Unit
<b>DRIVE PART</b>						
Quiescent current	I <sub>CC</sub>	No loading	–	15	20	mA
Output offset voltage 1	V <sub>OO1</sub>	CH 1, CH 4	–70	0	70	mV
Output offset voltage2	V <sub>OO2</sub>	CH 2, CH 3	–90	–	90	mV
Max.output amplitude 1	V <sub>OM1</sub>	CH 1, CH 4	3	4.2	–	V
Max.output amplitude 2	V <sub>OM2</sub>	CH 2, CH 3 (R <sub>L</sub> =24Ω)	8	10.4	–	V
Voltage gain 1	G <sub>VC1</sub>	V <sub>IN</sub> =0.1V <sub>RMS</sub> , 1kHz, sinewave. Input op-amp → Buffer CH 1, CH 4	10	12.0	14	dB
Voltage gain 2	G <sub>VC2</sub>	V <sub>IN</sub> =0.1V <sub>RMS</sub> , 1kHz, sinewave. Input op-amp → Buffer CH 2, CH 3	16	18	20	dB
Mute on voltage	V <sub>MON</sub>	–	2.0	–	–	V
Mute off voltage	V <sub>MOFF</sub>	–	–	–	0.5	V
<b>INPUT OP-AMP PART</b>						
Input offset voltage	V <sub>OFOP</sub>	–	–10	0	10	mV
Input bias current	I <sub>BOP</sub>	–	–	–	300	nA
High level output voltage	V <sub>OHOP</sub>	–	10	10.9	–	V
Low level output voltage	V <sub>OLOP</sub>	–	–	1.1	1.8	V
Output driving current sink	I <sub>SINK</sub>	Input op-amp output → V <sub>CC</sub> & 1.2kΩ	1	–	–	mA
Output driving current source	I <sub>SOURCE</sub>	Input op-amp output → GND & 1.2kΩ	1	–	–	mA
Slew rate	SR	100kHz square-wave 2Vp-p output	–	1	–	V / μs

## APPLICATION INFORMATION

### 1. MUTE

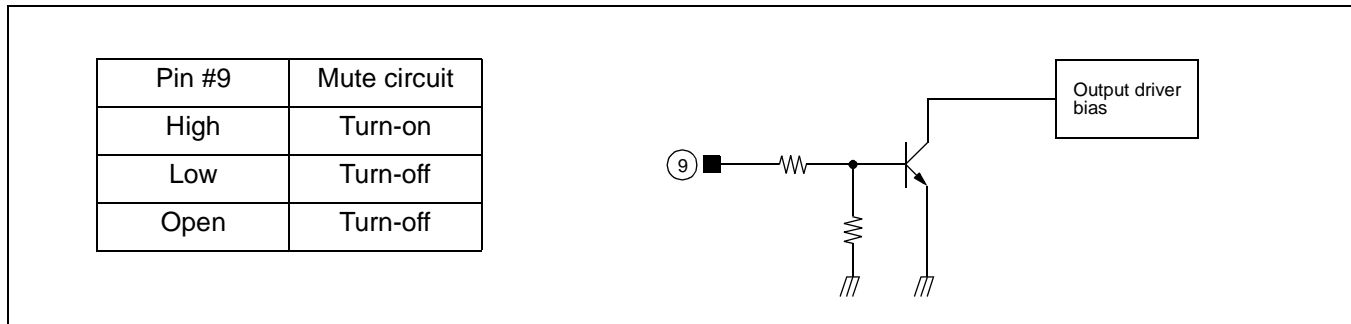

- When the voltage level of the mute pin is above 2V, the mute circuit is activated so that the output circuit will be muted.
- When the mute pin #9 is open or the voltage of the mute pin #9 is below 0.5V, the mute circuit is stopped and the output circuit is operated normally.
- When the mute circuit is activated, the voltage level of output pins becomes  $1/2V_{CC}$  (approximately).

### 2. TSD (THERMAL SHUTDOWN)

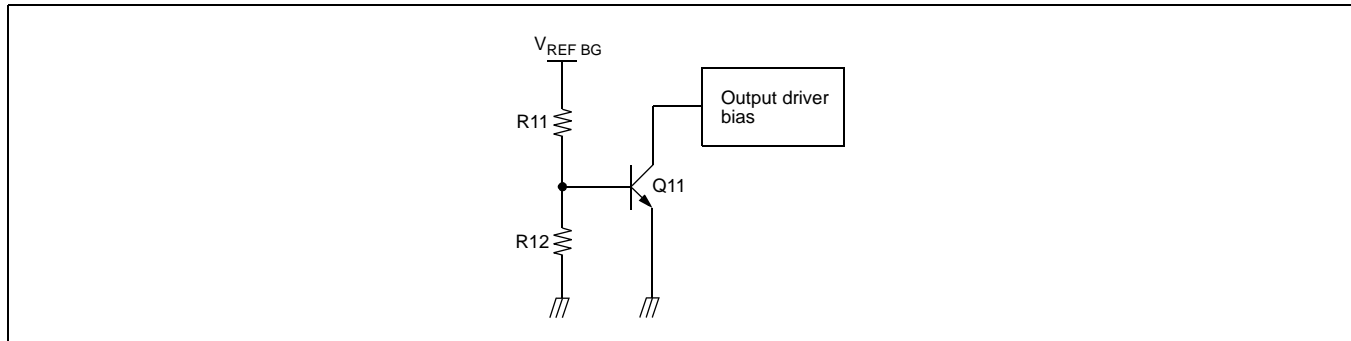

- If the chip temperature rises above 175°C, then the TSD (Thermal shutdown) circuit is activated and the output circuit is muted.
- The  $V_{REF\ BG}$  is the output voltage of the band-gap-referenced bias in circuit and acts as the input voltage of the TSD circuit.
- The base-emitter voltage of the TR, Q11 is designed to turn-on at 460mV.  

$$V_{BE} = V_{REF\ BG} \times R12 / (R11 + R12) = 460mV$$
- When the chip temperature rises up to 175°C, then the turn-on voltage of the Q11 will drop down to 460mV. (Hysteresis: 25°C) Hence, the Q11 would turn on so the output circuit will be muted.

### 3. DRIVER

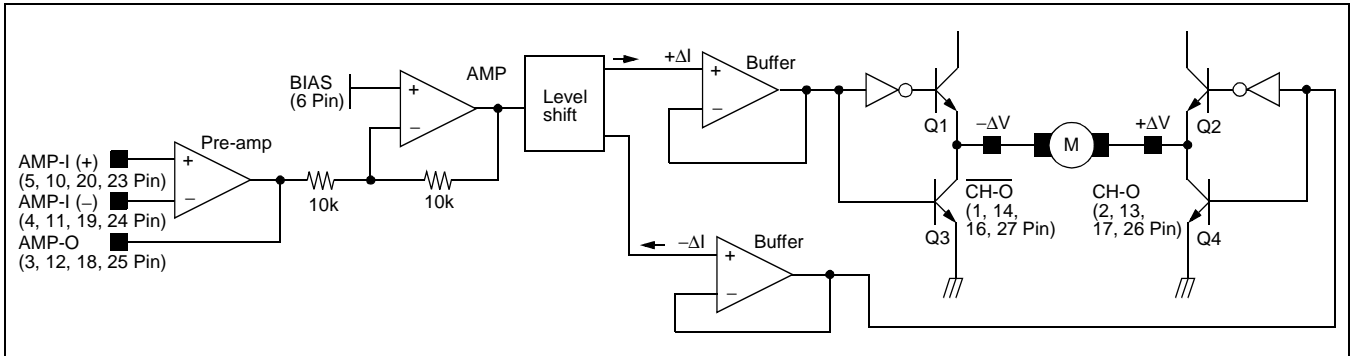

- The gain of pre-op. Amplifier can be changed by manipulating amp input resistor or feedback resistor.
- The voltage,  $V_{REF}$ , is the reference voltage given by the bias voltage of the pin #6.
- The level shift produces the current due to the difference between the pre amp output signal and the arbitrary reference (bias) signal. (The current produced as  $+\Delta I$  and  $-\Delta I$  is fed into the driver buffer. (CH1/CH4) The current produced as  $+2\Delta I$  and  $-2\Delta I$  is fed into the driver buffer. (CH2/CH3)
- Driver buffer drives the power TR of the output stage according to the state of the input signal.
- The output stage is the BTL driver and the motor is rotating in forward direction by operating TR Q1 and TR Q4. On the other hand, if TR Q2 and TR Q3 is operating, the motor is rotating in reverse direction.
- When the output voltage of Pre-Amp (Pin 3, 12, 18, 25) is below the  $V_{REF}$ , then the direction of the motor is in forward.
- When the output voltage of Pre-Amp (Pin 3, 12, 18, 25) is above the  $V_{REF}$ , then the direction of the motor in reverse.
- The gain ( $A_V$ ) of the drive circuit is as follows.

$$A_V = 20 \log \left[ \frac{4 V_{IN}}{V_{IN}} \right] = 12(dB) \quad (CH1/CH4)$$

$$A_V = 20 \log \left[ \frac{4 V_{IN}}{V_{IN}} \right] = 18(dB) \quad (CH1/CH4)$$

### 4. CONNECT A BY-PASS CAPACITOR, 0.1 $\mu$ F BETWEEN THE SUPPLY VOLTAGE SOURCE.

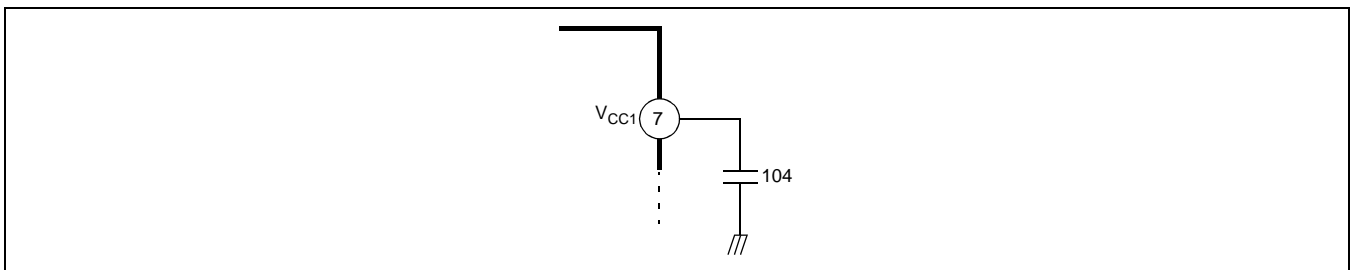

### 5. RADIATION FIN IS CONNECTING TO THE INTERNAL GND OF THE PACKAGE. CONNECT THE FIN TO THE EXTERNAL GND.

**ELECTRICAL CHARACTERISTICS CURVES**

**1.  $V_{CC}$  vs  $I_{CC}$  (No load)**

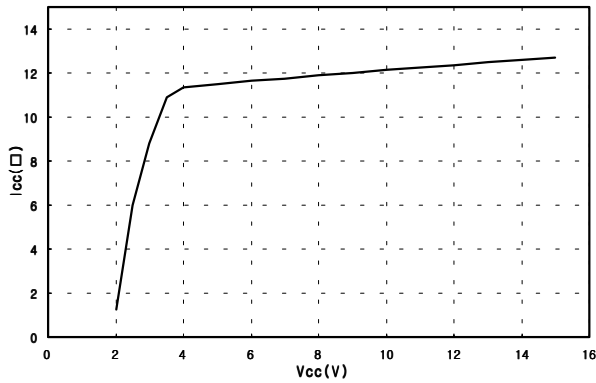

**2. AMP-I (+) vs OUTPUT VOLTAGE**

Figures can be obtained by changing of AMP-I (+) from 0V to 5V, shows the voltage difference between CH-O and  $\overline{\text{CH-O}}$ . (AMP-I (+) and AMP-O are shorted.)

**1. CH 1 and CH 4 (12dB)**

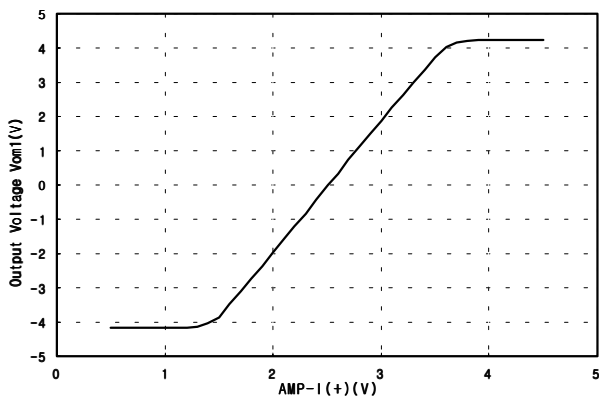

**2. CH 2 and CH 3 (18dB)**

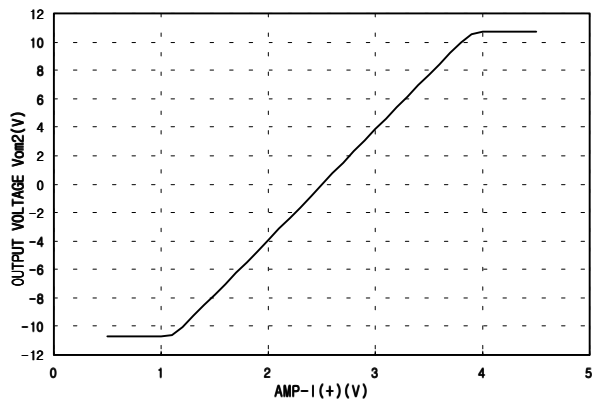



### 3. V<sub>CC</sub> vs Gain

1. CH 1 and CH 4 (12dB)

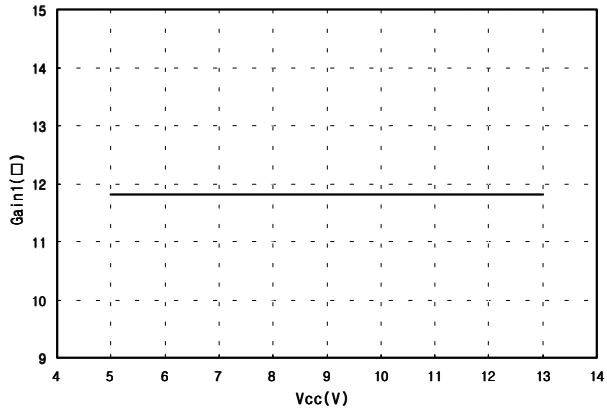

2. CH 2 and CH 3 (18dB)

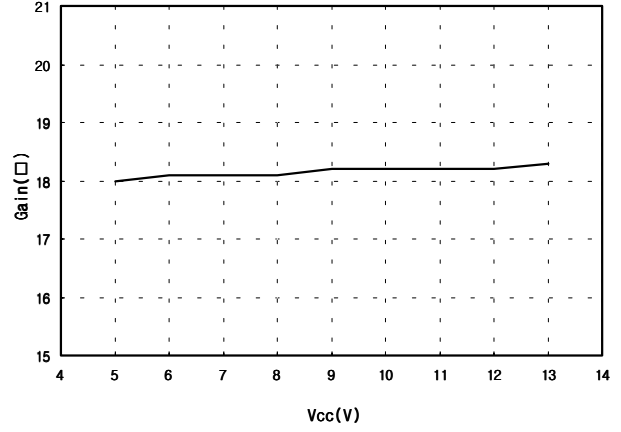

TEST CIRCUIT

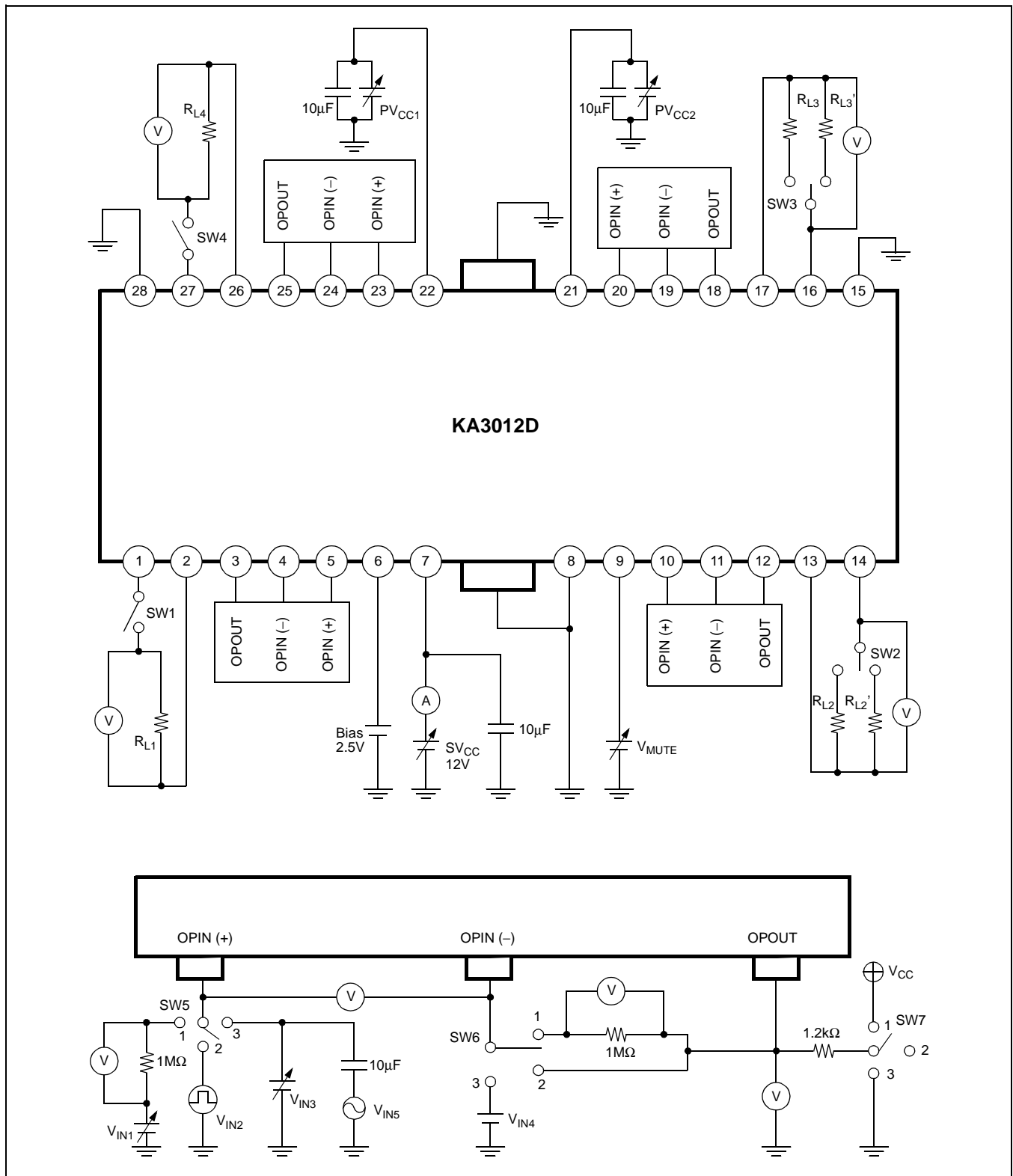

APPLICATION CIRCUIT

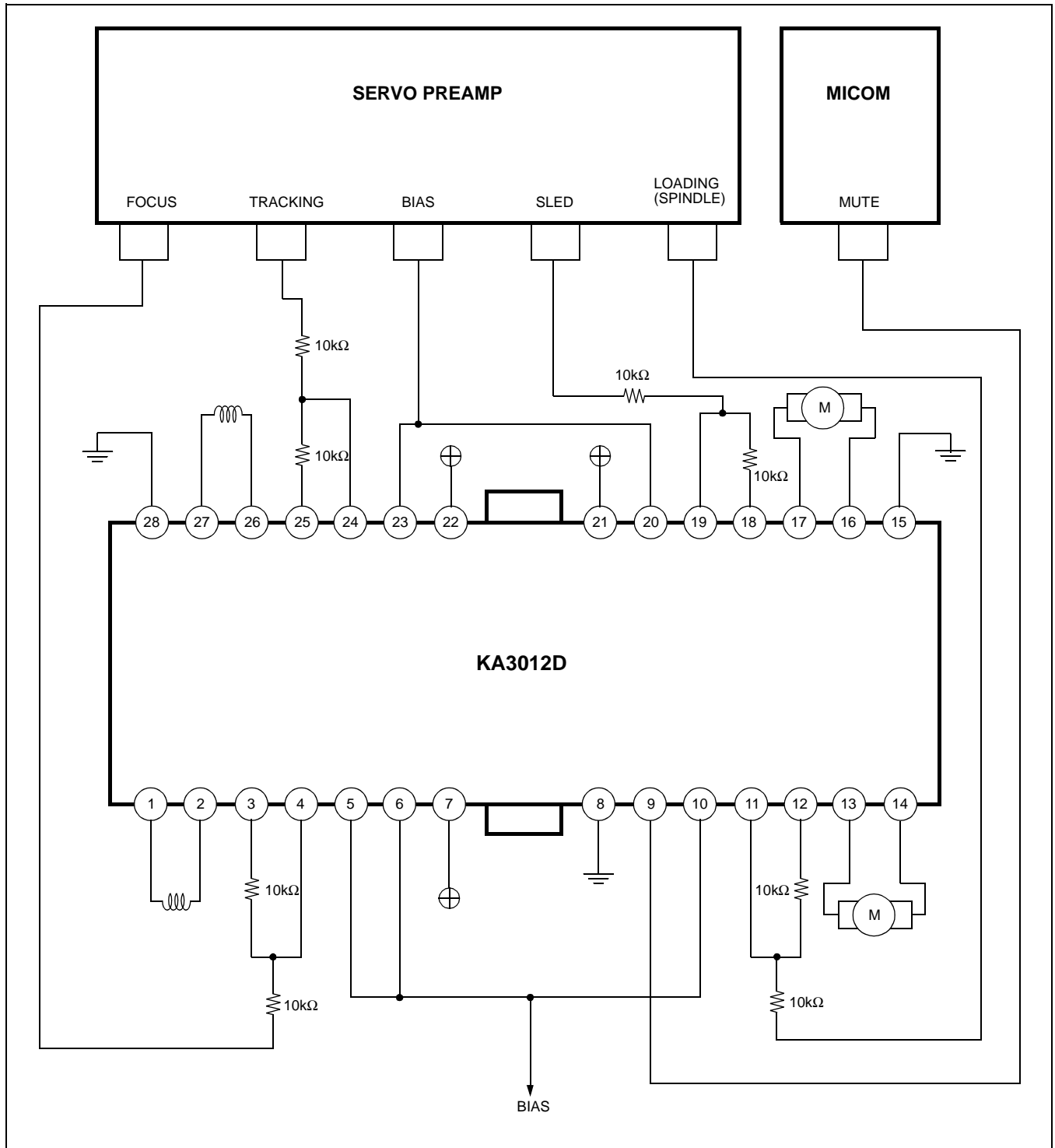

NOTES