

# Compact Cassette Datasheets

## TDK MA-X



I measured MOLs at 11 points from 20 Hz to 1 kHz with a distortion limit of 3%, and measured saturation output levels (SOLs) at nine points from 1 to 16 kHz. I used a Nakamichi 582 deck for substantially all of the record/playback tests. The three Tables list the MOL (3% distortion limit) at 40, 125, and 800 Hz. I selected 40 Hz because it lies in a frequency region important in music for organ and other sources of low-frequency energy. The Tables also present SOL data for 2, 4, and 10 kHz. The SOL curves were very similar in shape, particularly within a tape type. Other data: <https://www.elektronikjk.com>

Maximum Output Level (dB, re: Dolby Level: 200 nWb/m at 400 Hz)

| MOL hdl3 = 3% |        |        | SOL    |       |        |
|---------------|--------|--------|--------|-------|--------|
| 40 Hz         | 125 Hz | 800 Hz | 2 kHz  | 4 kHz | 10 kHz |
| + 4.2         | + 9.0  | + 10.8 | + 11.8 | + 8.7 | 0.0    |

S/N Ratio (dBA):64.7  
 Response Limit (-3 dB) at Dolby Level (kHz):12.1  
 Modulation noise (dB):-52.4  
 Bias (dB):+ 0.1  
 Sensitivity (dB):+ 1.2

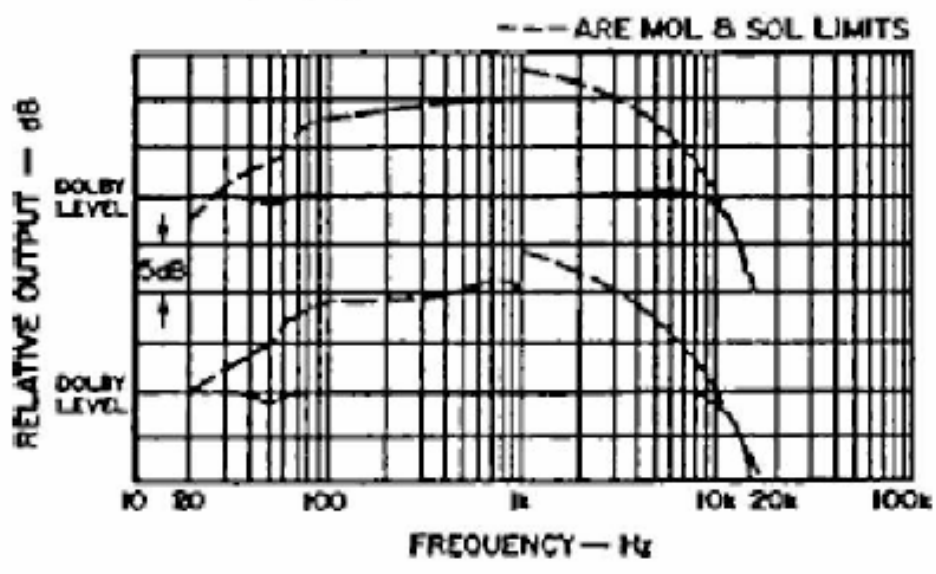

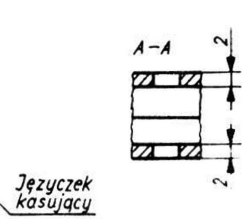
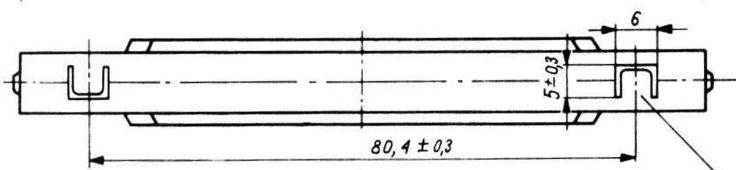
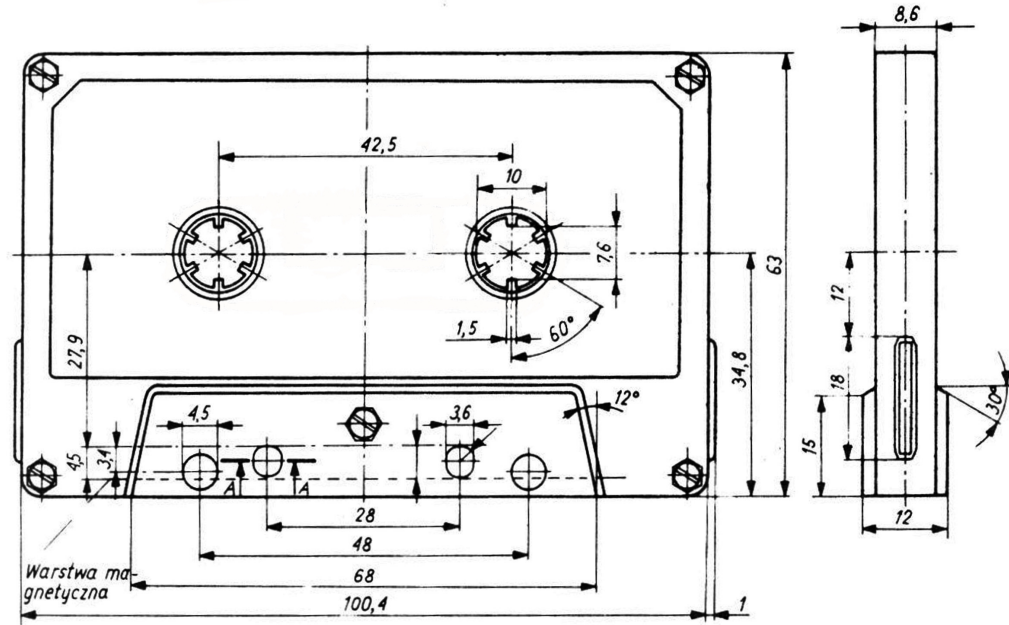
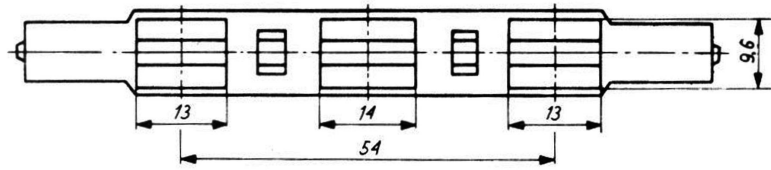

Językzek kasujący

